

Core Drilling Pump specifications

Pump Series	Model	Rated Pressure (psi)	Continuous Duty Capacity	Intermittent Duty Capacity	Gallons per Revolution	Seal Diameter (in)	No. of Cylinders	Stroke (in)		Weight (lbs)	Pump Type	Length (in)	Width (in)	Height (in)	Mechanical Efficiency	Cast Ductile Iron	Cast Aluminum Bronze	HP-Forged Carbon Steel	HP-Forged Stainless Steel	API-Forged Carbon Steel	API-Forged Stainless Steel
A04 2.6/3.2 HP	A0410	900	4.25 GPM @ 400 RPM	5.31 GPM @ 500 RPM	0.0106	1.250	2	1.00		49	Piston	5.60	8.00	20.50	90%	•					
	A0411	750	5.14 GPM @ 400 RPM	6.43 GPM @ 500 RPM	0.0129	1.375	2	1.00		49	Piston	5.60	8.00	20.50	90%	•					
	A0413	550	7.18 GPM @ 400 RPM	8.98 GPM @ 500 RPM	0.0180	1.625	2	1.00		49	Piston	5.60	8.00	20.50	90%	•					
I04 2.6/3.2 HP	I0410	900	4.25 GPM @ 400 RPM	5.31 GPM @ 500 RPM	0.0106	1.250	2	1.00		45	Piston	16.50	8.00	7.50	90%	•					
	I0411	750	5.14 GPM @ 400 RPM	6.43 GPM @ 500 RPM	0.0129	1.375	2	1.00		45	Piston	16.50	8.00	7.50	90%	•					
	I0413	550	7.18 GPM @ 400 RPM	8.98 GPM @ 500 RPM	0.0180	1.625	2	1.00		45	Piston	16.50	8.00	7.50	90%	•					
E04 6.7/8.5 HP	E0410	1,000	9.56 GPM @ 450 RPM	12.22 GPM @ 575 RPM	0.0212	1.250	4	1.00		100	Piston	9.0	8.50	17.50	90%	•					
	E0411	825	11.57 GPM @ 450 RPM	14.78 GPM @ 575 RPM	0.0257	1.375	4	1.00		100	Piston	9.0	8.50	17.50	90%	•					
	E0413	600	16.16 GPM @ 450 RPM	20.65 GPM @ 575 RPM	0.0359	1.625	4	1.00		100	Piston	9.0	8.50	17.50	90%	•					
L09 11.6/13.8 HP	L0913	1,325	12.60 GPM @ 750 RPM	15.00 GPM @ 890 RPM	0.0606	1.625	3	2.25		229	Piston	24.75	12.25	11.00	90%	•				•	•
	L0914	1,150	14.60 GPM @ 750 RPM	17.40 GPM @ 890 RPM	0.0703	1.750	3	2.25		229	Piston	24.75	12.25	11.00	90%	•				•	•
	L0918	700	24.20 GPM @ 750 RPM	28.70 GPM @ 890 RPM	0.1162	2.250	3	2.25		229	Piston	24.75	12.25	11.00	90%	•				•	•
W11 25/36 HP	W1118	1,500	29.50 GPM @ 750 RPM	35.5 GPM @ 900 RPM	0.1420	2.250	3	2.75		405	Piston	31.0	16.00	13.50	90%	•					
	W1122	1,000	44.20 GPM @ 750 RPM	53.0 GPM @ 900 RPM	0.2121	2.750	3	2.75		405	Piston	31.0	16.00	13.50	90%	•					
L11 37/52 HP	L1114	2,500	21.50 GPM @ 900 RPM	30.40 GPM @ 1275 RPM	0.0859	1.750	3	2.75		443	Piston	32.50	16.00	13.50	90%			•	•		
	L1118	1,500	35.50 GPM @ 900 RPM	50.30 GPM @ 1275 RPM	0.1420	2.250	3	2.75		443	Piston	32.50	16.00	13.50	90%	•	•	•	•		
	L1122	1,000	53.00 GPM @ 900 RPM	75.10 GPM @ 1275 RPM	0.2121	2.750	3	2.75		443	Piston	32.50	16.00	13.50	90%	•	•	•	•		
L16 78/105 HP	L1614	3,250	34.90 GPM @ 1100 RPM	46.80 GPM @ 1475 RPM	0.1249	1.750	3	4.00		681	Piston	39.25	17.50	15.50	90%	•	•	•	•	•	•
	L1616	2,500	45.60 GPM @ 1100 RPM	61.10 GPM @ 1475 RPM	0.1632	2.000	3	4.00		681	Piston	39.25	17.50	15.50	90%	•	•	•	•	•	•
	L1618	1,975	57.70 GPM @ 1100 RPM	77.30 GPM @ 1475 RPM	0.2065	2.250	3	4.00		681	Piston	39.25	17.50	15.50	90%	•	•	•	•	•	•
	L1622	1,300	86.10 GPM @ 1100 RPM	115.50 GPM @ 1475 RPM	0.3085	2.750	3	4.00		681	Piston	39.25	17.50	15.50	90%	•	•	•	•	•	•

1. Broad product line

- Offer a broad array of BEAN piston and plunger pumps that serve a number of markets including industrial, oil and gas, sewer cleaning, reverse osmosis, horizontal and vertical drilling, and agricultural
- The plunger pump product line can be customized to operate up to 700 HP, and achieve pressures in excess of 10,000 psi (690 bar), flows up to 1,594 gpm (6,034 lpm), and temperatures to 400 F (204 C)
- The BEAN piston pump product line range in size from 3 to 450 HP, and achieve pressures up to 3,000 psi (207 bar) and flows up to 905 gpm (3,168 lpm) Offer a wide variety of materials that can handle numerous applications

2. Proven quality and reliability

- Every pump is tested prior to shipment to ensure it meets industry and customer standards
- Pumps manufactured in accordance with ISO-9001 quality standards
- Heavy duty construction and superior quality components, held to the highest achievable tolerances result in the most durable products on the market today
- Volumetric efficiencies up to 95%
- Mechanical efficiencies up to 97%

3. Technical capabilities

- Dedicated engineering department that partners with the customer to find solutions
- In house Product R&D focused on designing products to ensure customer success
- Advanced engineering knowledge concerning a variety of markets and applications

4. Cost savings

- Combination of component technology and design increase operation time while decreasing downtime, life cycle costs, and overall costs of ownership
- Designed to do more with less
- Ease of service
- Requires less energy, lowering the total cost of ownership

5. Product availability

- Manufacturing facility utilizing the latest in CNC machining centers, production planning systems, 3D CAD/CAM systems, and order distribution systems
- Robust established global supply chain
- Fast parts inventory resulting in reduced lead times and exceptional aftermarket support

6. Global presence/Distribution network

- Strategically established distribution network that ensures our products are easily accessible in a number of regions and markets
- Market specific distributors capable of providing the knowledge and service required to meet your needs

7. Stable - Long term industry leader

- Consistently top ranked most admired company by Fortune magazine
- Manufacturing pumps since 1884
- Industry leader since 1904
- Award winning pumps since 1915

8. Customer service

- Dedicated, market specific account managers
- Dedicated Stephenville customer service support representative

A04 Piston pump data

2.6 BHP continuous duty (3.2 BHP intermittent duty)

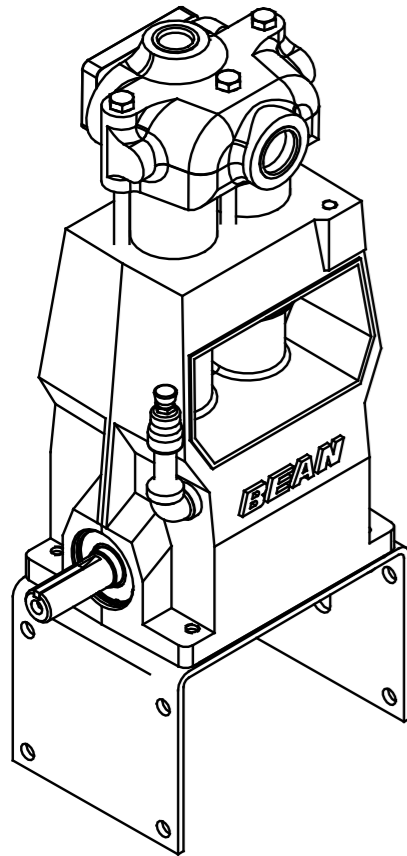

Standard Cast ISO Drawing

Specifications

Pump model	A04 (metric)
Configuration	Vertical Duplex Piston
Number of Pistons	2
Continuous Duty	2.6 BHP
Intermittent Duty	3.2 BHP
Stroke Length	1.0 Inches
Frame Load Rating	1,140 lbs
Pump Weight (Average)	43 lbs
Direction of Rotation	Either
Internal Gear Ratio	NA
Intermittent Duty Speed Rating	500 RPM
Continuous Duty Speed Rating	400 RPM
Ball Valve Max Speed Rating	NA
Minimum Speed	300 RPM
Mechanical Efficiency	90%
Lubrication System (Standard)	Splash, Gravity Return
Lube Oil Capacity	1 Quart
Lube Oil Type	SAE 30
Maximum Fluid Temperature	140 °F (250 °F Capability)
Minimum Fluid Temperature	0 °F (-20 °F Capability)
Standard Suction Size	1.00 Inch NPT
Standard Discharge Size	0.50 Inch NPT 0.75 Inch NPT
Fluid End Material	Cast Iron, Aluminum Bronze
Valve Types	Disc Valves
Hydraulic Motor Mount	SAE A - 2 Bolt with 7/8"-13T

Performance data

Pump model	Piston diameter (in)	Displacement (GAL/REV)	Maximum pressure (PSI)	Pump capacity (GPM) @ input speed (RPM)				
				300 RPM	350 RPM	375 RPM	400 RPM	500 RPM
A0410	1.250	0.0106	850	3.19	3.72	3.98	4.25	5.31
A0411	1.375	0.0129	750	3.86	4.50	4.82	5.14	6.43
A0413	1.625	0.0180	550	5.39	6.28	6.73	7.18	8.98

* Horsepower based on 85 or 90% mechanical efficiency. Actual application horsepower requirements can be calculated using the equation:
 $BHP = (GPM * PSI) / (1714 * 0.85 \text{ or } 0.90)$

* Pump capacities shown are based on 100% volumetric efficiency.

* Dimensions shown are for general sizing purposes and should not be used for construction. Contact FMC for actual dimensions of pump ordered.

* FMC reserves the right to modify this information without prior notice.

Cast pump engineering dimensional outline

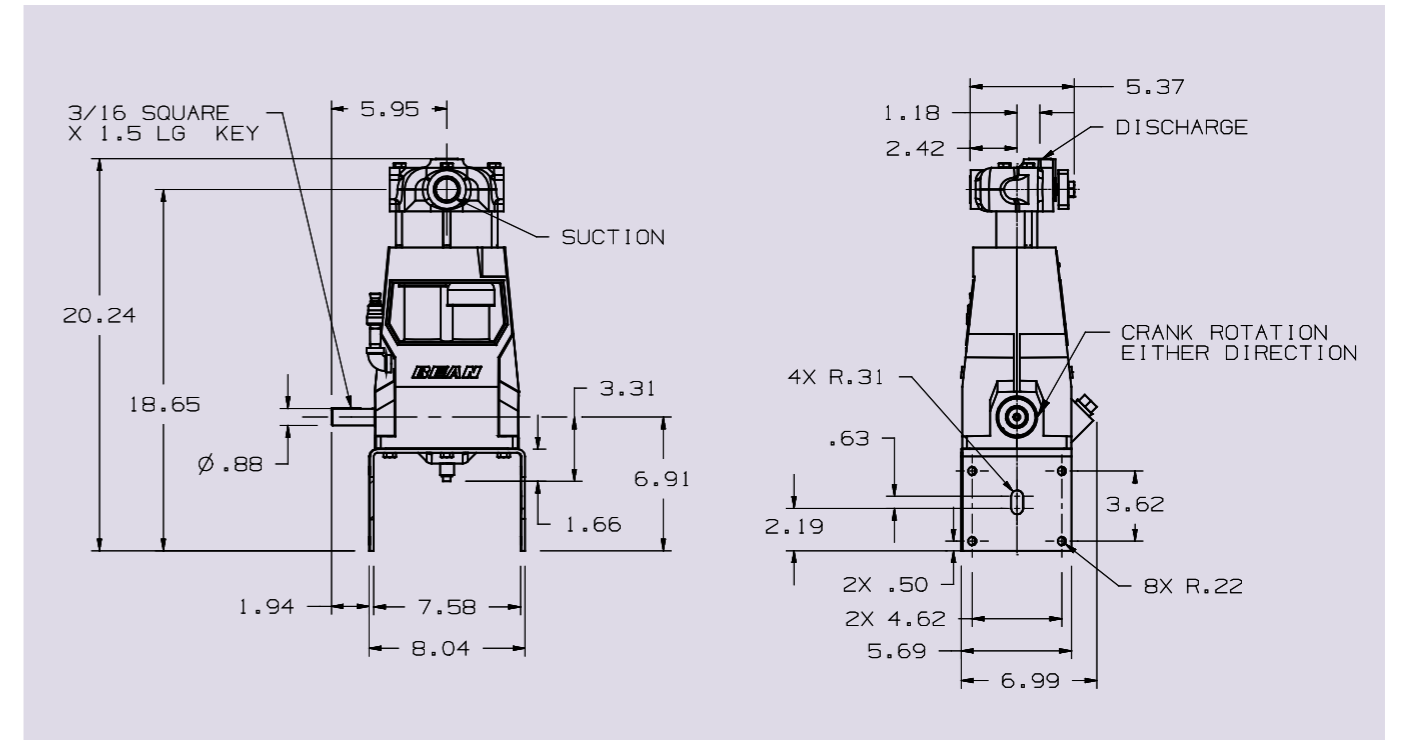

A04 NPSHR value

Standard disc valves

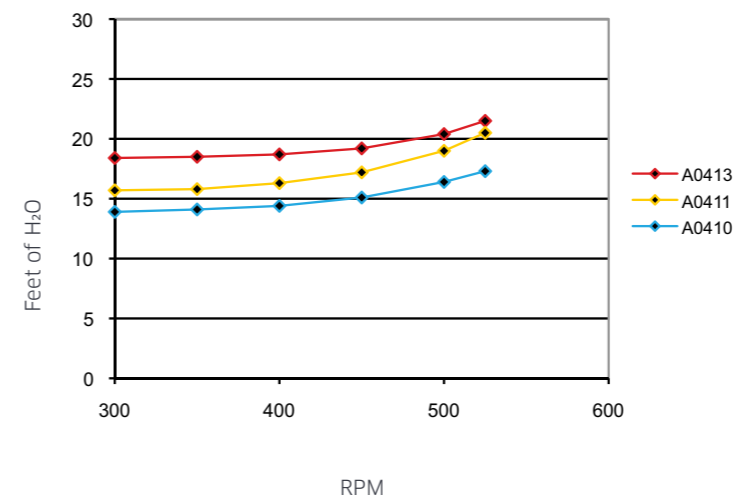

⚠️ TechnipFMC recommends NPSHa (available) exceeds NPSHr (required) by 5 feet of water.

⚠️ Take special consideration when calculating NPSHa. Recalculate NPSHa after pump model has been selected for more accurate values.

⚠️ NPSHr values are in feet of water. If you are pumping a different liquid than water, convert the required NPSH from water to the liquid being pumped by dividing the published NPSHr value by the specific gravity of the liquid being pumped.

⚠️ TechnipFMC published NPSHr values are based on test data collected on specific pumps at the factory and are estimated values. Actual NPSHr values for an ordered pump can only be determined by a factor test. For NPSH critical applications, contact the factory for additional information and request an NPSHr test performed on your pump before shipment.

⚠️ Pump drawing dimensions in inches.

I04 Piston pump data

2.6 BHP continuous duty (3.2 BHP intermittent duty)

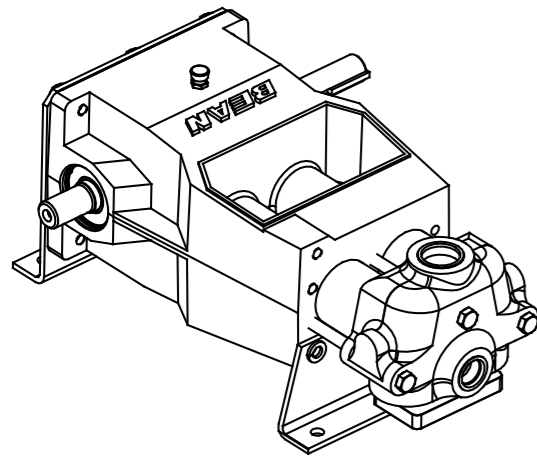

Standard Cast ISO Drawing

Specifications

Configuration	I04 Horizontal duplex piston
Number of Pistons	2
Continuous Duty	2.6 BHP
Intermittent Duty	3.2 BHP
Stroke Length	1.0 Inches
Frame Load Rating	1,140 lbs
Pump Weight (Average)	43 lbs
Direction of Rotation	Either
Internal Gear Ratio	NA
Intermittent Duty Speed Rating	500 RPM
Continuous Duty Speed Rating	400 RPM
Ball Valve Max Speed Rating	NA
Minimum Speed	100 RPM
Mechanical Efficiency	90%
Lubrication System (Standard)	Splash, Gravity Return
Lube Oil Capacity	1 Quart
Lube Oil Type	SAE 30
Maximum Fluid Temperature	140 °F (250 °F Capability)
Minimum Fluid Temperature	0 °F (-20 °F Capability)
Standard Suction Size	1.00 Inch NPT
Standard Discharge Size	0.50 Inch NPT
0.75 Inch NPT	1.00 Inch NPT
Fluid End Material	Cast Iron, Aluminum Bronze
Valve Types	Disc Valves
Hydraulic Motor Mount	SAE A - 2 Bolt with 7/8"-13T

Cast pump engineering dimensional outline

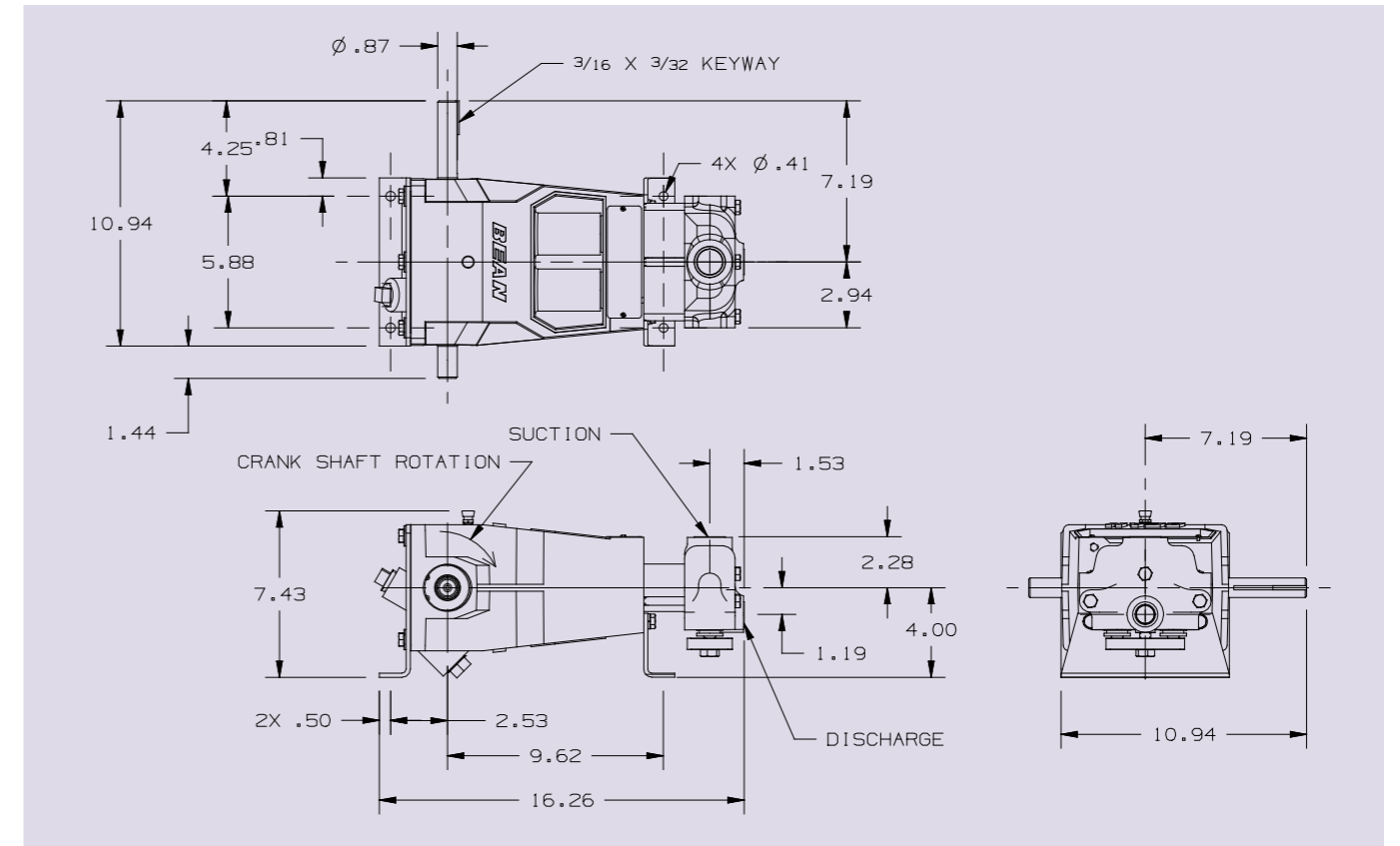

Performance data

Pump model	Piston diameter (in)	Displacement (GAL/REV)	Maximum pressure (PSI)	Pump capacity (GPM) @ input speed (RPM)				
				300 RPM	350 RPM	375 RPM	400 RPM	500 RPM
I0410	1.250	0.0106	850	3.19	3.72	3.98	4.25	5.31
I0411	1.375	0.0129	750	3.86	4.50	4.82	5.14	6.43
I0413	1.625	0.0180	550	5.39	6.28	6.73	7.18	8.98

* Horsepower based on 85 or 90% mechanical efficiency. Actual application horsepower requirements can be calculated using the equation:
 $BHP = (GPM * PSI) / (1714 * 0.85 \text{ or } 0.90)$

* Pump capacities shown are based on 100% volumetric efficiency.

* Dimensions shown are for general sizing purposes and should not be used for construction. Contact FMC for actual dimensions of pump ordered.

* FMC reserves the right to modify this information without prior notice.

I04 NPSHR value

Standard disc valves

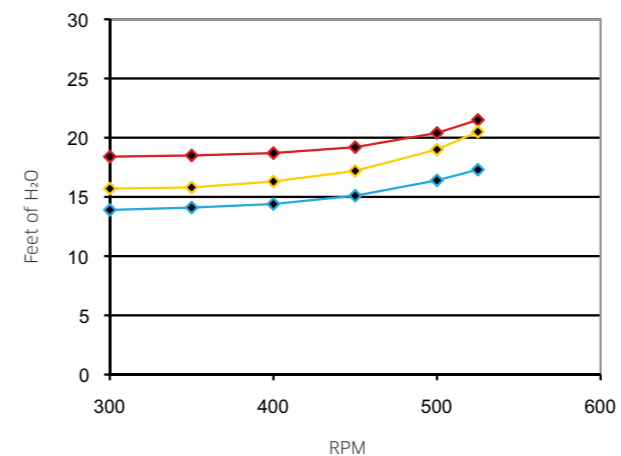

⚠️ TechnipFMC recommends NPSHa (available) exceeds NPSHr (required) by 5 feet of water.

⚠️ Take special consideration when calculating NPSHa. Recalculate NPSHa after pump model has been selected for more accurate values.

⚠️ NPSHr values are in feet of water. If you are pumping a different liquid than water, convert the required NPSH from water to the liquid being pumped by dividing the published NPSHr value by the specific gravity of the liquid being pumped.

⚠️ TechnipFMC published NPSHr values are based on test data collected on specific pumps at the factory and are estimated values. Actual NPSHr values for an ordered pump can only be determined by a factor test. For NPSH critical applications, contact the factory for additional information and request an NPSHr test performed on your pump before shipment.

⚠️ Pump drawing dimensions in inches.

E04 Piston pump data

6.7 BHP continuous duty (8.5 BHP intermittent duty)

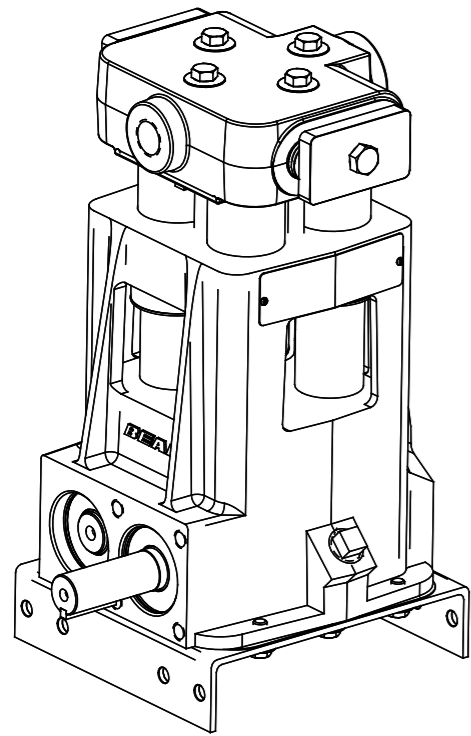

Standard Cast ISO Drawing

Specifications

Configuration	Verticle quadruplex piston
Number of Pistons	4
Continuous Duty	6.7 BHP
Intermittent Duty	8.5 BHP
Stroke Length	1.0 Inches
Frame Load Rating	1,240 lbs
Pump Weight (Average)	80 lbs
Direction of Rotation	Either
Internal Gear Ratio	1:1
Intermittent Duty Speed Rating	575 RPM
Continuous Duty Speed Rating	450 RPM
Ball Valve Max Speed Rating	NA
Minimum Speed	390 RPM
Mechanical Efficiency	85%
Lubrication System (Standard)	Splash, Gravity Return
Lube Oil Capacity	1 Quart
Lube Oil Type	SAE 30
Maximum Fluid Temperature	140 °F (250 °F Capability)
Minimum Fluid Temperature	0 °F (-20 °F Capability)
Standard Suction Size	1.25 Inch NPT
Standard Discharge Size	0.75 Inch NPT
Fluid End Material	Cast Iron, Aluminum Bronze
Valve Types	Disc Valves
Hydraulic Motor Mount	SAE A - 2 Bolt with 1"-6B

Cast pump engineering dimensional outline

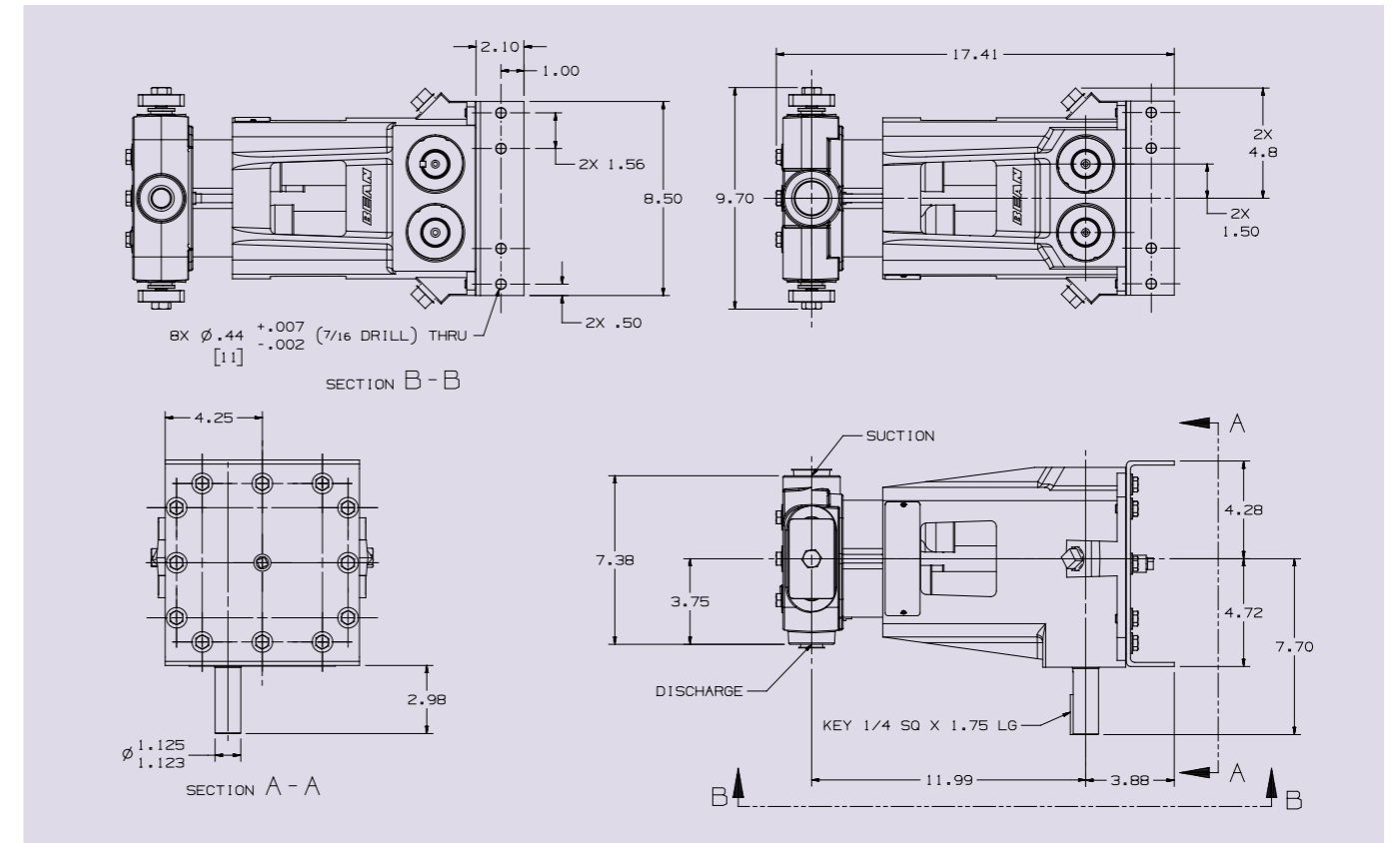

Performance data

Pump model	Piston diameter (in)	Displacement (GAL/REV)	Maximum pressure (PSI)	Pump capacity (GPM) @ input speed (RPM)				
				390 RPM	400 RPM	425 RPM	450 RPM	575 RPM
E0410	1.250	0.0212	1,000	8.29	8.50	9.03	9.56	12.22
E0411	1.375	0.0257	800	10.03	10.28	10.93	11.57	14.78
E0413	1.625	0.0359	600	14.01	14.36	15.26	16.16	20.65

* Horsepower based on 85 or 90% mechanical efficiency. Actual application horsepower requirements can be calculated using the equation:
 $BHP = (GPM * PSI) / (1714 * 0.85 \text{ or } 0.90)$

* Pump capacities shown are based on 100% volumetric efficiency.

* Dimensions shown are for general sizing purposes and should not be used for construction. Contact FMC for actual dimensions of pump ordered.

* FMC reserves the right to modify this information without prior notice.

E04 NPSHR value

Standard disc valves

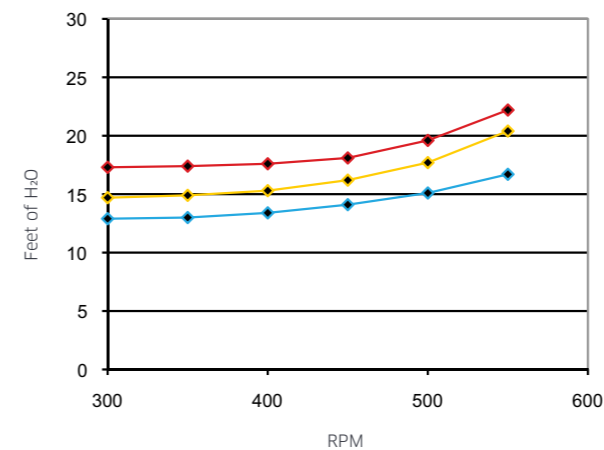

⚠️ TechnipFMC recommends NPSHa (available) exceeds NPSHr (required) by 5 feet of water.

⚠️ Take special consideration when calculating NPSHa. Recalculate NPSHa after pump model has been selected for more accurate values.

⚠️ NPSHr values are in feet of water. If you are pumping a different liquid than water, convert the required NPSH from water to the liquid being pumped by dividing the published NPSHr value by the specific gravity of the liquid being pumped.

⚠️ TechnipFMC published NPSHr values are based on test data collected on specific pumps at the factory and are estimated values. Actual NPSHr values for an ordered pump can only be determined by a factor test. For NPSH critical applications, contact the factory for additional information and request an NPSHr test performed on your pump before shipment.

⚠️ Pump drawing dimensions in inches.

L09 Piston pump data

11.6 BHP continuous duty (13.9 BHP intermittent duty)

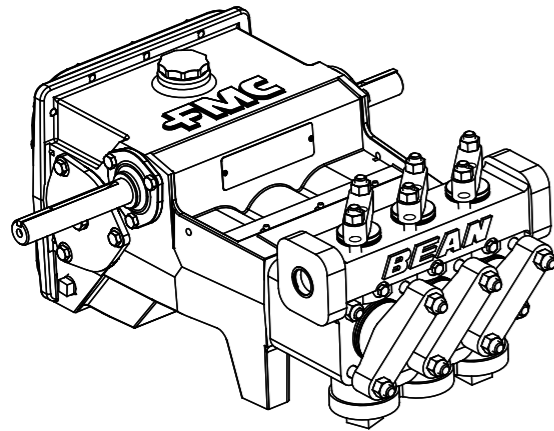

Standard Cast ISO Drawing

Specifications

Configuration	Horizontal Triplex Piston
Number of Pistons	3
Continuous Duty	11.6 BHP
Intermittent Duty	13.8 BHP (High Volume)
Stroke Length	2.25 Inches
Frame Load Rating	2,800 lbs
Pump Weight (Average)	200 lbs
Direction of Rotation	Top of shaft away from head
Internal Gear Ratio	3.6:1
Intermittent Duty Speed Rating	890 RPM
Continuous Duty Speed Rating	750 RPM
Ball Valve Max Speed Rating	625 RPM
Minimum Speed	360 RPM
Mechanical Efficiency	85%
Lubrication System (Standard)	Splash, Gravity Return
Lube Oil Capacity	2.25 Quarts
Lube Oil Type	SAE 30
Maximum Fluid Temperature	140 °F (250 °F Capability)
Minimum Fluid Temperature	0 °F (-20 °F Capability)
Standard Suction Size	1.50 Inch NPT
Standard Discharge Size	1.00 Inch NPT
Fluid End Material	Cast Iron
Valve Types	Disc Valves, Ball Valves
Hydraulic Motor Mount	SAE B - 4 Bolt with 1.25"-14T SAE C - 4 Bolt with 1.25"-14T

Performance data

Pump Model	Piston Diameter (in)	Displacement (GAL/REV)	Maximum Pressure (PSI)	Pump Capacity (GPM) @ Input Speed (RPM)				
				350 RPM	625 RPM	700 RPM	750 RPM	890 RPM
L0913	1.625	0.0168	1,200	5.9	10.5	11.8	12.6	15.0
L0914	1.750	0.0195	1,000	6.8	12.2	13.7	14.6	17.4
L0918	2.250	0.0323	700	11.3	20.2	22.6	24.2	28.7

* Horsepower based on 85 or 90% mechanical efficiency. Actual application horsepower requirements can be calculated using the equation:
 $BHP = (GPM * PSI) / (1714 * 0.85 \text{ or } 0.90)$

* Pump capacities shown are based on 100% volumetric efficiency.

* Dimensions shown are for general sizing purposes and should not be used for construction. Contact FMC for actual dimensions of pump ordered.

* FMC reserves the right to modify this information without prior notice.

Cast pump engineering dimensional outline

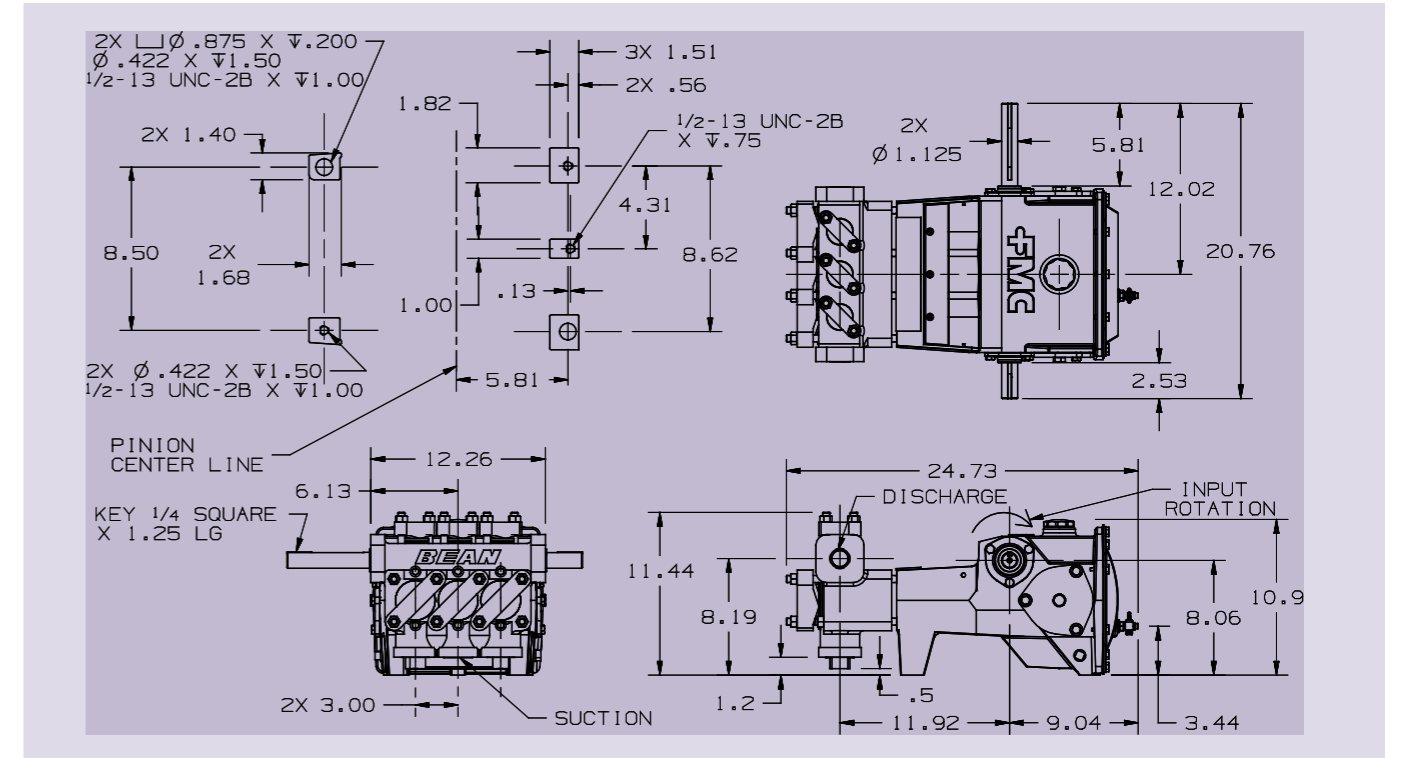

L09 NPSHR value

Standard disc valves

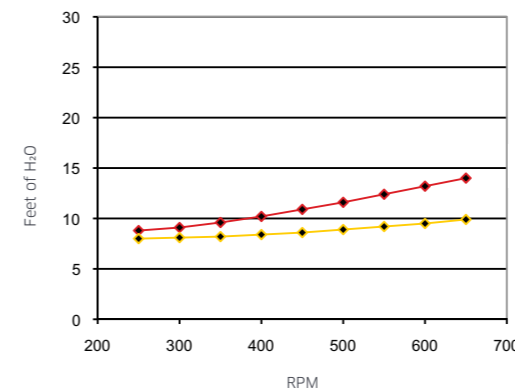

L09 NPSHR value

Standard ball valves

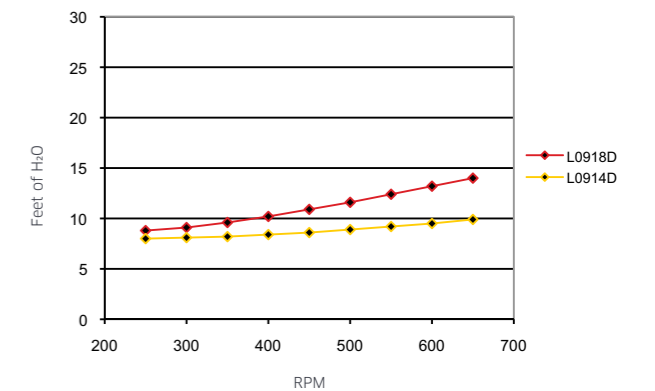

☞TechnipFMC recommends NPSHa (available) exceeds NPSHr (required) by 5 feet of water.

☞Take special consideration when calculating NPSHa. Recalculate NPSHa after pump model has been selected for more accurate values.

☞NPSHr values are in feet of water. If you are pumping a different liquid than water, convert the required NPSH from water to the liquid being pumped by dividing the published NPSHr value by the specific gravity of the liquid being pumped.

☞TechnipFMC published NPSHr values are based on test data collected on specific pumps at the factory and are estimated values. Actual NPSHr values for an ordered pump can only be determined by a factor test. For NPSH critical applications, contact the factory for additional information and request an NPSHr test performed on your pump before shipment.

☞Pump drawing dimensions in inches.

W11 Piston pump data

30 BHP continuous duty (36 BHP intermittent duty)

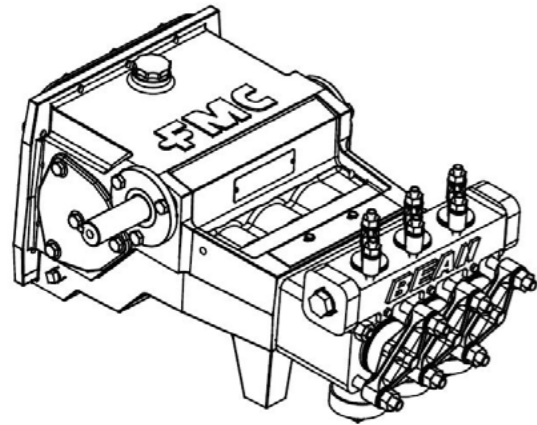

Standard Cast ISO Drawing

Specifications

Configuration	Horizontal Triplex Piston
Number of Pistons	3
Continuous Duty	30 BHP
Intermittent Duty	36 BHP (High Volume)
Stroke Length	2.75 Inches
Frame Load Rating	2,800 lbs
Pump Weight (Average)	200 lbs
Direction of Rotation	Top of shaft away from head
Internal Gear Ratio	3.6:1
Intermittent Duty Speed Rating	890 RPM
Continuous Duty Speed Rating	750 RPM
Ball Valve Max Speed Rating	625 RPM
Minimum Speed	360 RPM
Mechanical Efficiency	85%
Lubrication System (Standard)	Splash, Gravity Return
Lube Oil Capacity	2.25 Quarts
Lube Oil Type	SAE 30
Maximum Fluid Temperature	140 °F (250 °F Capability)
Minimum Fluid Temperature	0 °F (-20 °F Capability)
Standard Suction Size	1.50 Inch NPT
Standard Discharge Size	1.00 Inch NPT
Fluid End Material	Cast Iron
Valve Types	Disc Valves, Ball Valves
Hydraulic Motor Mount	SAE B - 4 Bolt with 1.25"-14T SAE C - 4 Bolt with 1.25"-14T

Performance data

Pump Model	Piston Diameter (in)	Displacement (GAL/REV)	Maximum Pressure (PSI)	Pump Capacity (GPM) @ Input Speed (RPM)				
				360 RPM	500 RPM	635 RPM	750 RPM	900 RPM
W1118	2.250	0.0394	1,000	14.2	19.7	25.0	29.5	35.5
W1122	2.750	0.0589	1,000	21.2	29.5	37.4	44.2	53.0

* Horsepower based on 85 or 90% mechanical efficiency. Actual application horsepower requirements can be calculated using the equation:
 $BHP = (GPM * PSI) / (1714 * 0.85 \text{ or } 0.90)$

* Pump capacities shown are based on 100% volumetric efficiency.

* Dimensions shown are for general sizing purposes and should not be used for construction. Contact FMC for actual dimensions of pump ordered.

* FMC reserves the right to modify this information without prior notice.

Cast pump engineering dimensional outline

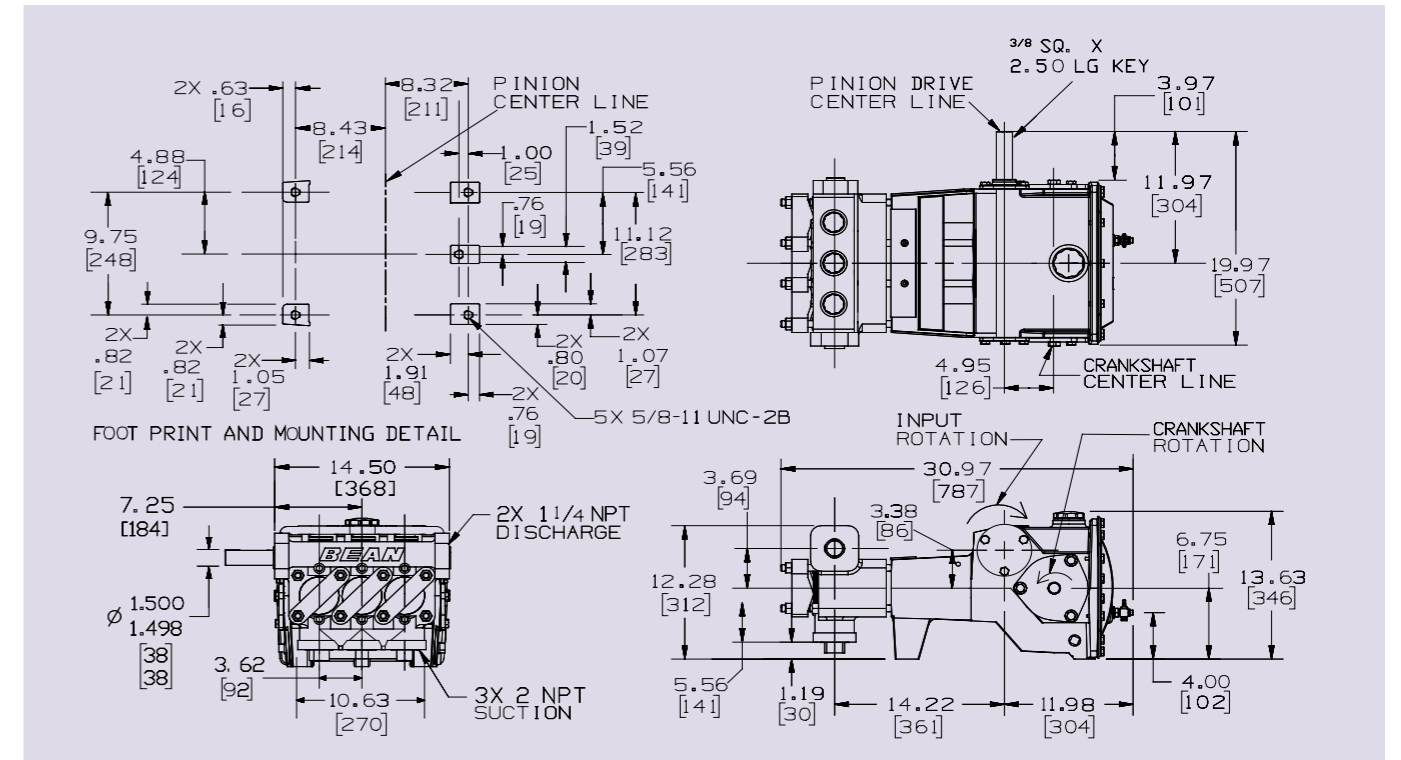

W11 NPSHR value

Standard disc valves

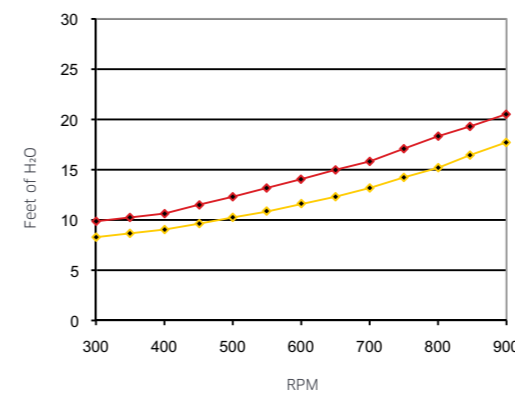

W11 NPSHR value

Standard ball valves

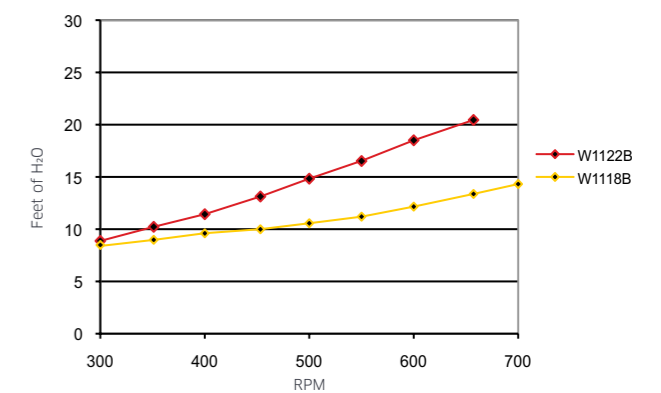

☞TechnipFMC recommends NPSHa (available) exceeds NPSHr (required) by 5 feet of water.

☞Take special consideration when calculating NPSHa. Recalculate NPSHa after pump model has been selected for more accurate values.

☞NPSHr values are in feet of water. If you are pumping a different liquid than water, convert the required NPSH from water to the liquid being pumped by dividing the published NPSHr value by the specific gravity of the liquid being pumped.

☞TechnipFMC published NPSHr values are based on test data collected on specific pumps at the factory and are estimated values. Actual NPSHr values for an ordered pump can only be determined by a factor test. For NPSH critical applications, contact the factory for additional information and request an NPSHr test performed on your pump before shipment.

☞Pump drawing dimensions in inches.

L11 Piston pump data

37 BHP continuous duty (52 BHP intermittent duty)

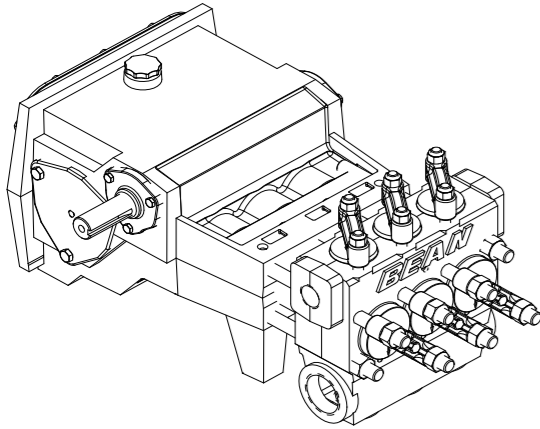

Standard Cast ISO Drawing

Specifications

Configuration	Horizontal Triplex Piston
Number of Pistons	3
Continuous Duty	37 BHP
Intermittent Duty	52 BHP (High Volume)
Stroke Length	2.75 Inches
Frame Load Rating	6,000 lbs
Pump Weight (Average)	460 lbs
Direction of Rotation	Top of pinion shaft away from head
Internal Gear Ratio	3.6:1
Intermittent Duty Speed Rating	1,275 RPM
Continuous Duty Speed Rating	900 RPM
Ball Valve Max Speed Rating	1050 RPM
Minimum Speed	360 RPM
Mechanical Efficiency	85%
Lubrication System (Standard)	Splash, Gravity Return
Lube Oil Capacity	1 Gallon
Lube Oil Type	SAE 30
Maximum Fluid Temperature	140 °F (250 °F Capability)
Minimum Fluid Temperature	0 °F (-20 °F Capability)
Standard Suction Size	2.50 Inch NPT
Standard Discharge Size	1.25 Inch NPT
Fluid End Material	Ductile Iron, Nickel Aluminum bronze
Valve Types	Disc Valves, Ball Valves, Abrasion Resistant (AR) Valves
Hydraulic Motor Mount	SAE B - 2 Bolt with 1.25"-14T SAE C - 4 Bolt with 1.25"-14T

Performance data

Pump Model	Piston Diameter (in)	Displacement (GAL/REV)	Maximum Pressure (PSI)	Pump Capacity (GPM) @ Input Speed (RPM)				
				360 RPM	690 RPM	900 RPM	1050 RPM	1275 RPM
L1114	1.750	0.0239	2,500	8.6	16.5	21.5	25.1	30.4
L1118	2.250	0.0394	1,500	14.2	27.2	35.5	41.4	50.3
L1122	2.750	0.0589	1,000	21.2	40.7	53.0	61.9	75.1

* Horsepower based on 85 or 90% mechanical efficiency. Actual application horsepower requirements can be calculated using the equation:
 $BHP = (GPM * PSI) / (1714 * 0.85 \text{ or } 0.90)$

* Pump capacities shown are based on 100% volumetric efficiency.

* Dimensions shown are for general sizing purposes and should not be used for construction. Contact FMC for actual dimensions of pump ordered.

* FMC reserves the right to modify this information without prior notice.

Cast pump engineering dimensional outline

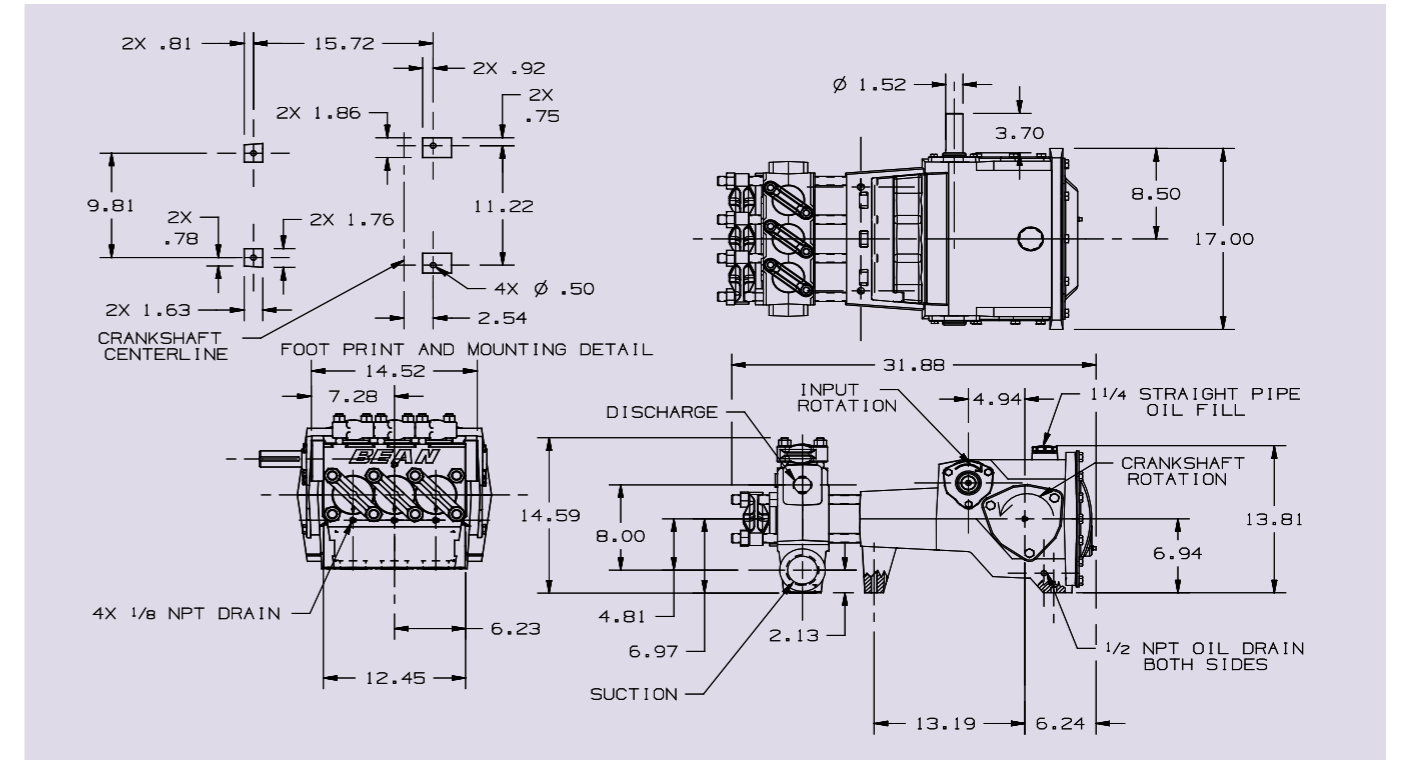

L11 NPSHR value Standard disc valves

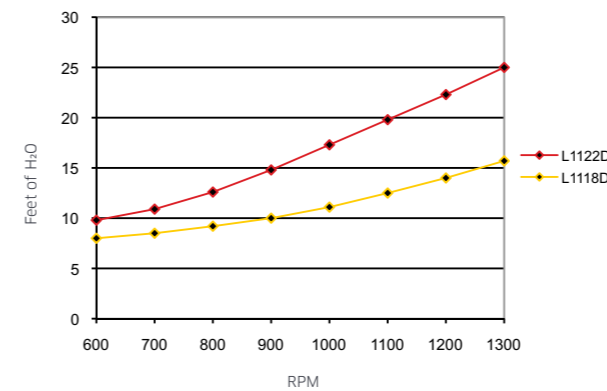

L11 NPSHR value Standard ball valves

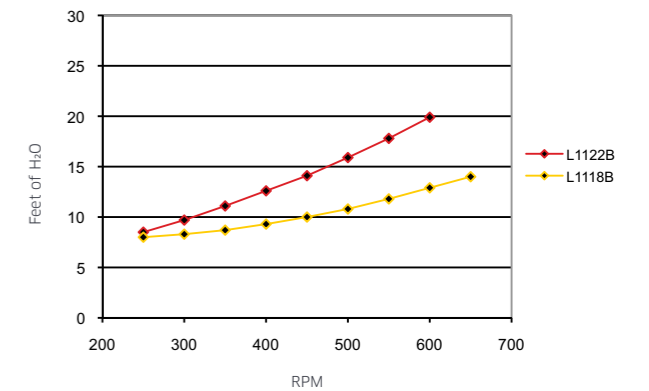

⚠️TechnipFMC recommends NPSHa (available) exceeds NPSHr (required) by 5 feet of water.

⚠️Take special consideration when calculating NPSHa. Recalculate NPSHa after pump model has been selected for more accurate values.

⚠️NPSHr values are in feet of water. If you are pumping a different liquid than water, convert the required NPSH from water to the liquid being pumped by dividing the published NPSHr value by the specific gravity of the liquid being pumped.

⚠️TechnipFMC published NPSHr values are based on test data collected on specific pumps at the factory and are estimated values. Actual NPSHr values for an ordered pump can only be determined by a factor test. For NPSH critical applications, contact the factory for additional information and request an NPSHr test performed on your pump before shipment.

⚠️Pump drawing dimensions in inches.

L16 Piston pump data

78 BHP continuous duty (105 BHP intermittent duty)

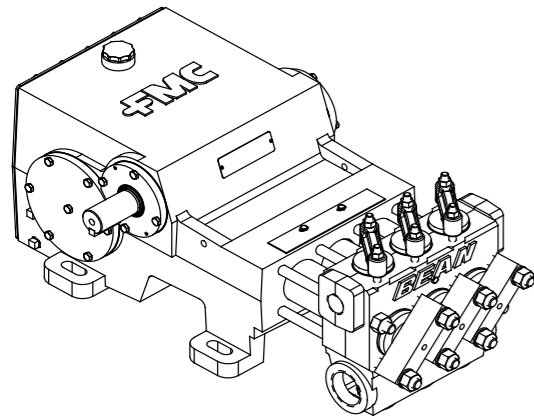

Standard Cast ISO Drawing

Specifications

Configuration	Horizontal Triplex Piston
Number of Pistons	3
Continuous Duty	78 BHP
Intermittent Duty	105 BHP (High Volume)
Stroke Length	4.0 Inches
Frame Load Rating	7,850 lbs
Pump Weight (Average)	705 lbs
Direction of Rotation	Top of inion shaft away from head
Internal Gear Ratio	3.94:1
Intermittent Duty Speed Rating	1,475RPM
Continuous Duty Speed Rating	1,100 RPM
Ball Valve Max Speed Rating	900 RPM
Minimum Speed	394 RPM
Mechanical Efficiency	85%
Lubrication System (Standard)	Splash, Gravity Return
Lube Oil Capacity	10 Quartz
Lube Oil Type	SAE 80W90
Maximum Fluid Temperature	140 °F (250 °F Capability)
Minimum Fluid Temperature	0 °F (-20 °F Capability)
Standard Suction Size	STD - 2.50 inch NPT HV - 3.00 inch NPT
Standard Discharge Size	STD - 1.25 Inch NPT HV - 1.50 Inch NPT
Fluid End Material	Ductile Iron, Nickel Aluminum Bronze
Valve Types	Disc Valves + Abrasion Resistant (AR) Valves
Hydraulic Motor Mount	SAE C - 2 Bolt with 1.25" - 14T SAE C - 4 Bolt with 1.25" - 14T

Performance data

Pump Model	Piston Diameter (in)	Displacement (GAL/REV)	Maximum Pressure (PSI)	Pump Capacity (GPM) @ Input Speed (RPM)				
				100 RPM	200 RPM	300 RPM	325 RPM	400 RPM
L1614	1.750	0.0317	2,500	12.5	23.8	28.5	34.9	46.8
L1616	2.000	0.0414	2,500	16.3	31.1	37.3	45.6	61.1
L1618	2.250	0.0524	2,000	10.7	47.2	47.2	57.7	77.3
L1622	2.275	0.0783	1,300	30.9	70.5	70.5	86.1	115.5

* Horsepower based on 85 or 90% mechanical efficiency. Actual application horsepower requirements can be calculated using the equation:
BHP = (GPM * PSI) / (1714 * 0.85 or 0.90)

* Pump capacities shown are based on 100% volumetric efficiency.

* Dimensions shown are for general sizing purposes and should not be used for construction. Contact FMC for actual dimensions of pump ordered.

* FMC reserves the right to modify this information without prior notice.

Cast pump engineering dimensional outline

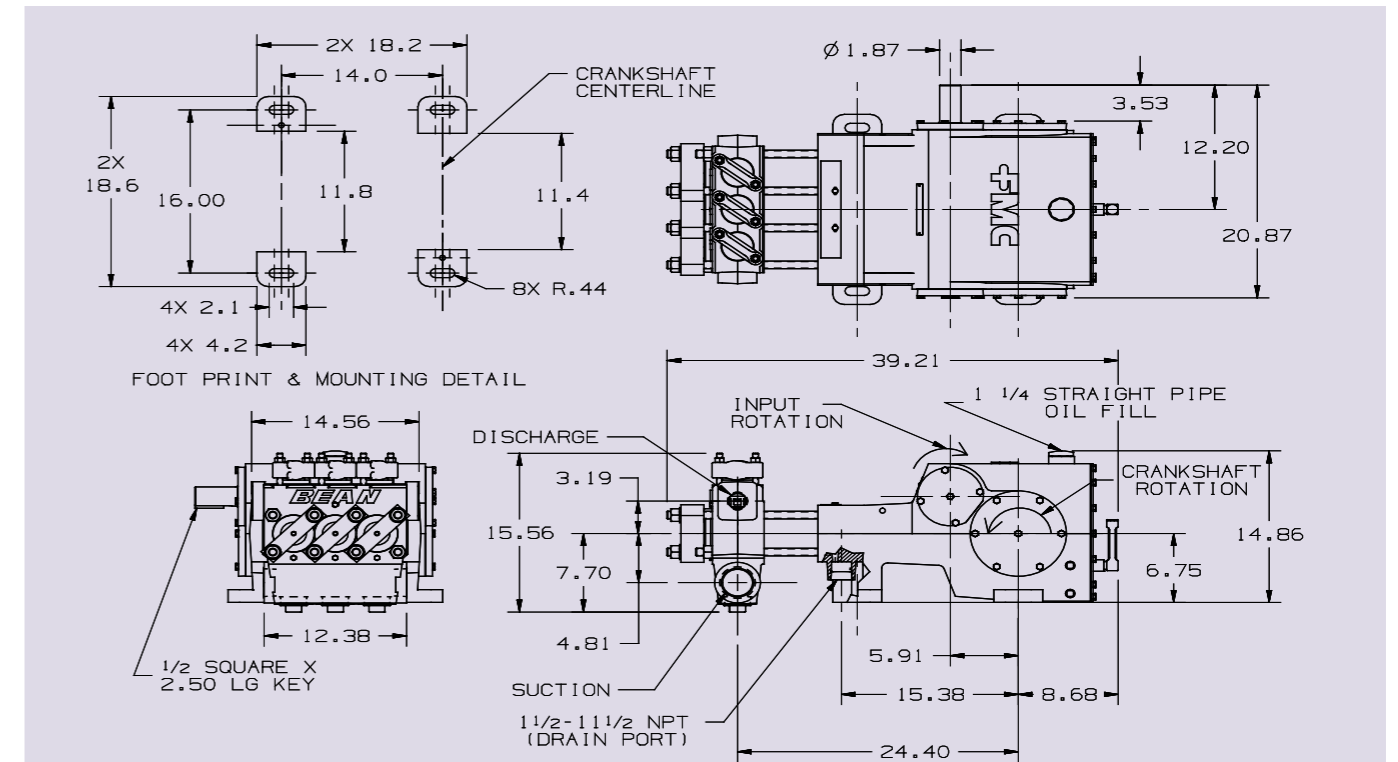

L16 NPSHR value Standard ball valves

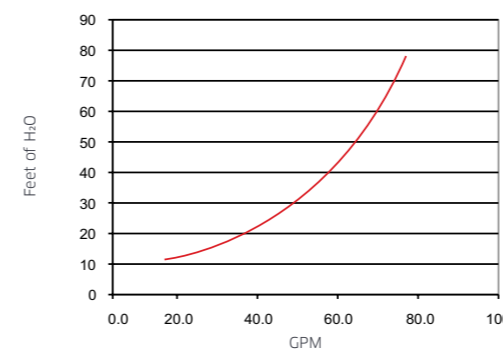

L16 NPSHR value Standard ball valves

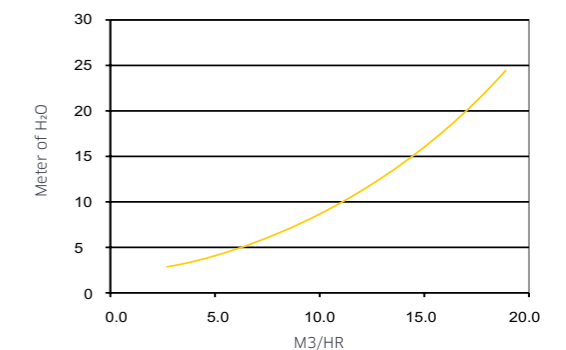

⚡TechnipFMC recommends NPSHa (available) exceeds NPSHr (required) by 5 feet of water.

⚡Take special consideration when calculating NPSHa. Recalculate NPSHa after pump model has been selected for more accurate values.

⚡NPSHr values are in feet of water. If you are pumping a different liquid than water, convert the required NPSH from water to the liquid being pumped by dividing the published NPSHr value by the specific gravity of the liquid being pumped.

⚡TechnipFMC published NPSHr values are based on test data collected on specific pumps at the factory and are estimated values. Actual NPSHr values for an ordered pump can only be determined by a factor test. For NPSH critical applications, contact the factory for additional information and request an NPSHr test performed on your pump before shipment.

⚡Pump drawing dimensions in inches.

