

# LIQUID-SPECIFIC PRODUCT LINE: STAINLESS STEEL VANE PUMPS

LVP SERIES™

Section	1761
Page	1761.1
Issue	A

## TABLE OF CONTENTS

Operating Range.....	1
Product Description.....	1
Related Products .....	1
Features & Benefits .....	2
Model Number Key .....	3
Parts Identification.....	3
Standard Materials of Construction .....	4
Specifications .....	4
Mechanical Seals.....	5
Dimensions – M-Drive Motor Mount (Displacement Sizes 01 & 02) .....	6
Dimensions – IEC M-Drive (Displacement Sizes 01 & 02).....	6
Dimensions – NEMA M-Drive (Displacement Sizes 01 & 02) .....	7
Dimensions – Footed Pump (Displacement Sizes 01 & 02) .....	8
Dimensions – D-Drive (Displacement Sizes 01 & 02).....	8
Dimensions – Pump Only (Displacement Sizes 05, 08, 19 & 23).....	9
Dimensions – Footed D-Drive (Displacement Sizes 05 & 08).....	10
Dimensions – Footed R-Drive (Displacement Sizes 19 & 23).....	10
NPSH Required .....	11

## PRODUCT DESCRIPTION

The LVP Series™ is designed for thin, corrosive industrial liquids, flammable liquids which require corrosion protection and applications where pressures or vacuum requirements exceed other pumps' capabilities. Vanes extend from slots on the rotor, sweeping liquid through a cam-shaped cavity. They offer the benefit of very low slip and high mechanical efficiency.

Viking's LVP Series™ stainless steel vane pumps is an industrial design which provides smooth flow at pressures higher than typically seen in a vane pump. It is offered in 3 frame sizes that include 6 capacities, all rated to 200 PSI/14 Bar differential pressure. The design is standard with hardened casing, PEEK vanes and push rods that work together to maximize pump life. A hard chrome-oxide coated shaft runs in silicon carbide bushings that further reduce maintenance and life cycle costs. When maintenance is required, installation of repair parts is a simple process. Vanes, push rods, mechanical seals and bushings are all readily accessible for easy replacement.

## RELATED PRODUCTS

Stainless Steel, 127A Series™: Catalog Section 1701



**LVP41017U**  
US Inch Design with ANSI Flange Ports



**LVP41057U**  
US Inch Design with ANSI Flange Ports

## OPERATING RANGE

SERIES	NOMINAL FLOW		MAXIMUM PRESSURE		TEMPERATURE RANGE		VISCOSITY RANGE	
	GPM	m <sup>3</sup> h	PSI	Bar	°F	°C	SSU	cSt
LVP Series™	20 - 160	4.3 - 36	200	14	0 to +275	-15 to +135	28 to 2,300	0.1 to 500

Section	1761
Page	1761.2
Issue	A

## LIQUID-SPECIFIC PRODUCT LINE: STAINLESS STEEL VANE PUMPS LVP SERIES™

### FEATURES & BENEFITS

- Pump design provides superior vacuum capability and volumetric efficiency. Provides application flexibility and reduces life-cycle costs.
- Bi-directional pumping design eliminates cost of second pump, piping, and valving needed for loading/unloading or line stripping. Provides application flexibility and reduces system costs.
- Combination of Hardened 316 stainless steel casing, PEEK vanes and push rods, and carbon construction provides broad chemical compatibility. Enhances application flexibility.
- High efficiency pump with self-priming, short-term dry-run-capabilities that handles entrained gases. Provides non-pulsing, low-shear flow.
- Pressure capabilities to 14 Bar (200 PSI), even on the thinnest liquids. Permits standardizing on single pump for multiple liquids and applications.
- Vane replacement is a 20 minute service item and does not require rotor and shaft removal or detachment of pump from system. Reduces scheduled downtime, and lowers cost of ownership.
- Better design with fewer parts reduces maintenance, and commonality of many parts between frame sizes reduces parts stocking needs. Provides better parts availability and lower cost of ownership.
- Interchangeable discs may be reversed instead of replaced when worn. Doubles useful life of parts, for reduced life-cycle cost.
- Raised-face flange ports, one-piece casing and bracket, and elastomeric O-ring seals on head, relief valve, and seal gland provides improved sealing reliability. Reduces downtime and cleanup, minimizes chemical exposure.
- 62 Rockwell C surfaced-hardened stainless steel casing. Extends casing and vane life, lowering life-cycle costs.
- PEEK plastic vanes and push rods. All non-metallic components minimize damage potential that is created by use of metal push rods and metal embedded plastic vanes. Extends pump life and lowers life-cycle cost.
- Hard silicon carbide sleeve bearing, standard. Extends pressure capability, minimizes wear, and lowers life-cycle costs.
- Hard chrome oxide coated shaft. Contributes to industry leading pressure capabilities of 200 PSI (14 Bar) and extends pump life, lowering life-cycle costs.
- Gauge ports standard for easy application of gauges or transducers. Simplifies installation of local or remote monitoring systems.
- Top-mounted, adjustable pressure relief valve standard. Eliminates cost of return-to-tank system. Protects pump from over-pressure.
- Rotatable casing with motor mount option on two smallest models [to 40 GPM (9 m<sup>3</sup>/h)]. Permits horizontal or vertical porting for easier installation.
- DIN or ANSI standard, opposite porting, allows easy-to-pipe, simple connection to local-standard piping, eliminating adapter leak points. Reduces costs of installation and maintenance.
- Motor speed operation up to 80 GPM @ 60-Hz (23 m<sup>3</sup>/h @ 50Hz) eliminates speed reducer and one shaft alignment, coupling and guard. Reduces footprint and system cost. Allows quicker, easier installation.

# LIQUID-SPECIFIC PRODUCT LINE: STAINLESS STEEL VANE PUMPS

LVP SERIES™

Section	1761
Page	1761.3
Issue	A

## MODEL NUMBER KEY

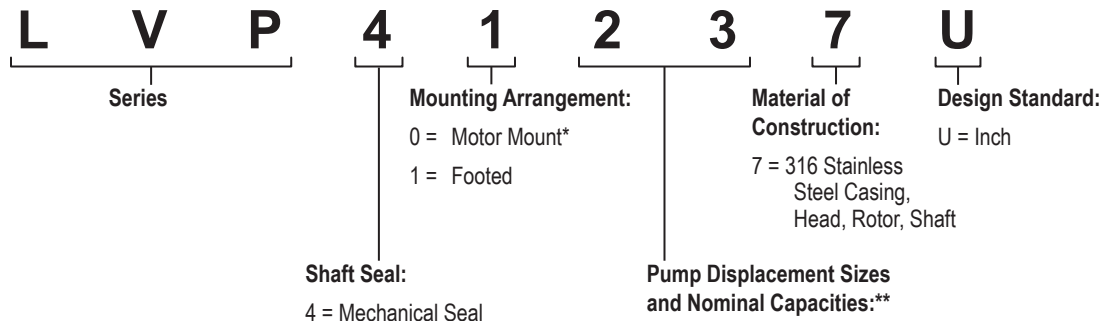

\* Motor Mount available on Displacement sizes 01 and 02 only. ANSI flanged pumps will direct mount to Nema frames 56C, 143/145TC and 182/184TC. DIN flanged pumps will direct mount to IEC B14 frames 90,100,112 and 132. Specify motor frame when ordering.

\*\* Capacities based on cataloged 60 Hz motor speeds. Metric capacity conversions are based on US GPM and rounded to the nearest whole number.

### Pump Displacement Sizes and Nominal Capacities:\*\*

- 01 = Capacity of 20 GPM / 4 m³/h.
- 02 = Capacity of 40 GPM / 9 m³/h.
- 05 = Capacity of 80 GPM / 18 m³/h.
- 08 = Capacity of 100 GPM / 23 m³/h.
- 19 = Capacity of 125 GPM / 29 m³/h.
- 23 = Capacity of 160 GPM / 36 m³/h.

## PARTS IDENTIFICATION

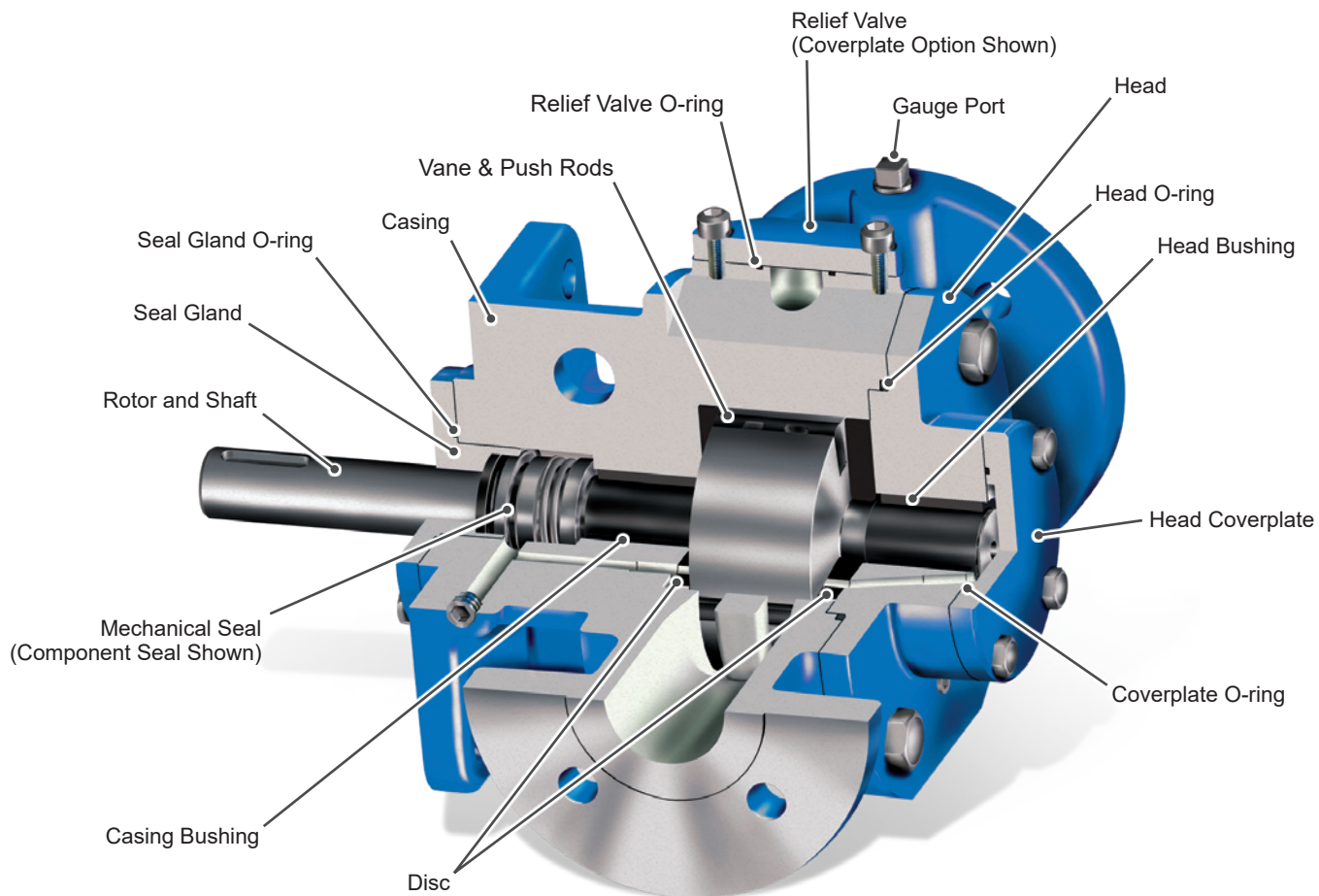

Section	1761
Page	1761.4
Issue	A

## LIQUID-SPECIFIC PRODUCT LINE: STAINLESS STEEL VANE PUMPS LVP SERIES™

### STANDARD MATERIALS OF CONSTRUCTION

Component	Standard Construction 0° to +275°F (-18° to +135°C)	PTFE Seal Construction 0° to +275°F (-18° to +135°C)	High Temp Construction ① 0° to +350°F (-18° to +177°C)
Casing	Hardened 316 Stainless Steel (ASTM A743 Grade CF8M)	Hardened 316 Stainless Steel (ASTM A743 Grade CF8M)	Hardened 316 Stainless Steel (ASTM A743 Grade CF8M)
Head, Relief Valve	316 Stainless Steel (ASTM A743 Grade CF8M)	316 Stainless Steel (ASTM A743 Grade CF8M)	316 Stainless Steel (ASTM A743 Grade CF8M)
Rotor & Shaft Assembly	316 Stainless Steel (ASTM A276)	316 Stainless Steel (ASTM A276)	316 Stainless Steel (ASTM A276)
Shaft Coating (Bushing Area)	Chrome Oxide	Chrome Oxide	Chrome Oxide
Vanes	PEEK ②	PEEK ②	High Temperature Carbon Graphite
Push Rods	PEEK ②	PEEK ②	Torlon®
Discs	Carbon Graphite	Carbon Graphite	Carbon Graphite
Bushings ③	Silicon Carbide	Silicon Carbide	Carbon Graphite ④
Mechanical Seal	FKM, Carbon / SiC	PTFE, Carbon / SiC	FKM, Carbon / SiC
O-Rings	FKM	PTFE	FKM
Foot Plate ⑤	Stainless Steel	Stainless Steel	Stainless Steel

① Additional operating clearances are needed for temperatures above 275°F. See ES-2.2 for clearance recommendations for higher temperatures.

② The maximum temperature rating for PEEK material is 275°F.

③ The maximum temperature rating for bushings varies by pump size. Silicon carbide bushings are rated to at least 275°F, and carbon graphite bushings are rated to at least 350°F. See ESB-3 for maximum temperature limit of bushings.

④ Pressures should be limited to 125 PSI when using carbon graphite bushings.

⑤ Foot plate for displacements 01 and 02 is 304 Stainless Steel, ASTM A351 Grade CF-8 (18-8). Foot plate for displacements 05, 08, 19 and 23 is Hardened 316 Stainless Steel (ASTM A 743, Grade CF8M).

Torlon® - Registered Trademark of Solvay Advanced Polymers.

### SPECIFICATIONS

Model Number	Port Size ②		Nominal Capacity at Maximum Rated Speed 22 cSt (100 SSU) Liquid				Max. Pressure ①		Maximum Hydrostatic Pressure		Maximum Recommended Temperature ③		Approximate Shipping Weight ④	
	Inch	DIN Flange	60 Hz Motor Speed		50 Hz Motor Speed ④									
			GPM	RPM	m³/h	RPM	PSI	BAR	PSI	BAR	Deg. F	Deg. C	Lb.	Kg.
LVP40017 LVP41017	1.5	40	20	1750	4	1450	200	14	300	21	275	135	80	36
LVP40027 LVP41027	1.5	40	40	1750	9	1450	200	14	300	21	275	135	80	36
LVP41057	2	50	80	1150	15	950	200	14	300	21	275	135	140	64
LVP41087	2	50	100	950	23	950	200	14	300	21	275	135	140	64
LVP41197	3	80	125	520 ⑤	29	520 ⑤	200	14	300	21	275	135	215	98
LVP41237	3	80	160	520 ⑤	36	520 ⑤	200	14	300	21	275	135	215	98

① See performance curves, which can be electronically generated with the Viking Pump Curve Generator, located on [www.vikingpump.com](http://www.vikingpump.com), for maximum discharge pressures at other viscosities or other speeds. Pressure should be limited to 125 PSI when using carbon graphite bushings.

② Opposite ports suitable for 150# ANSI steel or stainless steel companion flanges or flanged fittings standard, DIN-compatible flanges optional.

③ Based on standard construction, higher temperatures to 350°F (177°C) can be handled with special construction.

④ Metric conversions are based on US measurements and rounded to the nearest whole metric number.

⑤ 520 RPM is reduced speed.

**MECHANICAL SEALS**

**Standard Stuffing Box Dimension – Displacement Sizes 01 & 02**

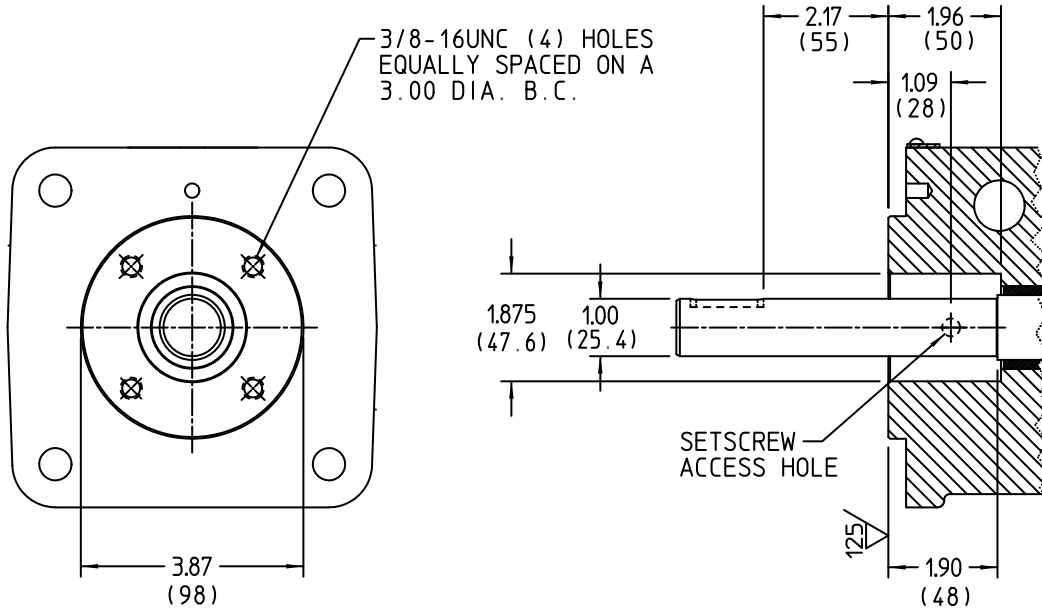

\* Cartridge seals may not be used on motor-mounted pumps. Use with foot-mount only.

**Standard Stuffing Box Dimension – Displacement Sizes 05, 08, 19 & 23**

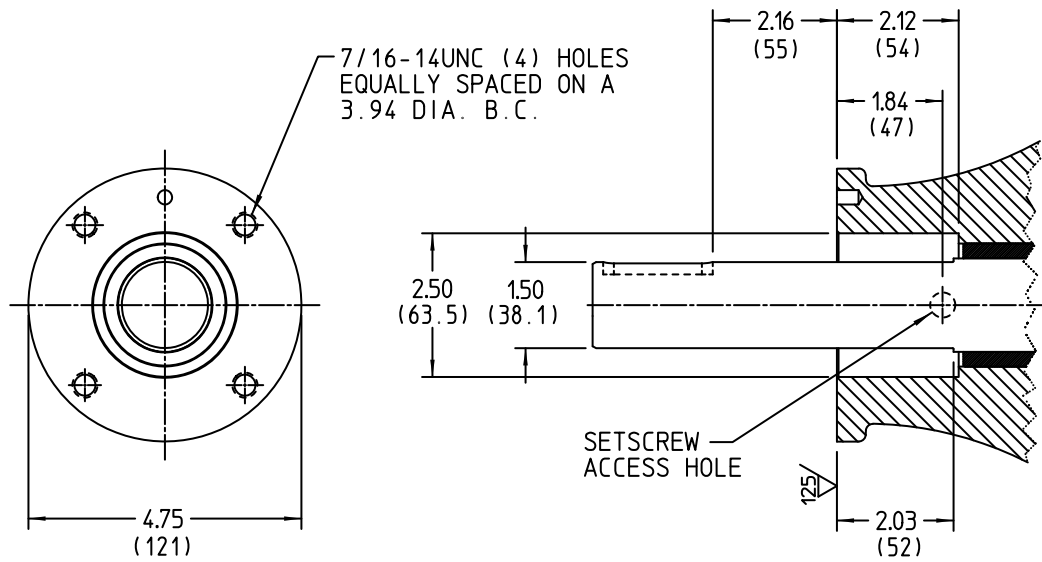

Seal Options	Faces	Elastomers
FlowServe Type 52 component single mechanical (standard)	CG/SiC	FKM
PTFE component single mechanical	CG/SiC	PTFE

Section	1761
Page	1761.6
Issue	A

**LIQUID-SPECIFIC PRODUCT LINE:  
STAINLESS STEEL VANE PUMPS  
LVP SERIES™**

**DIMENSIONS – M-DRIVE MOTOR MOUNT (DISPLACEMENT SIZES 01 & 02)**

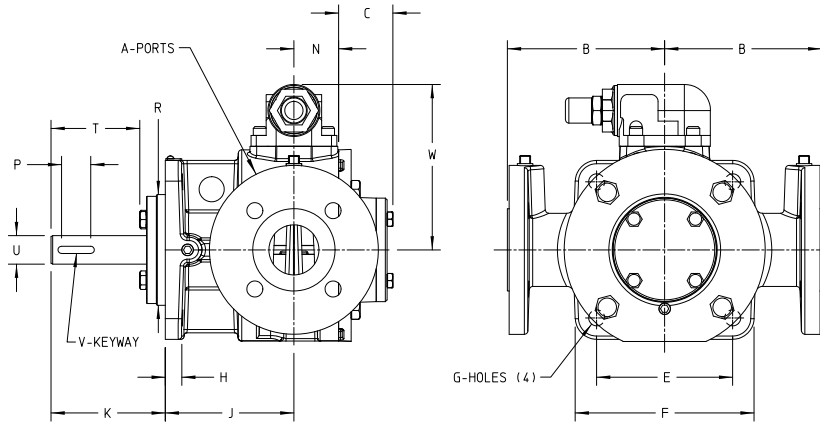

MODEL NO.		① A	B	C	E	F	G	H	J	K	N	P	R	T	② U	② V
LVP40017	in	1.50	5.50	1.90	4.75	6.25	0.56	0.62	4.50	4.00	1.56	1.02	3.875/3.873	3.11 / *1.63	1.00	.25 X .12
LVP40027	mm	40	140	48	121	159	14	16	114	102	40	26	98.43/98.37	79 / *41	25.4	6.4 X 3.2

\* T dimension when using a cartridge seal.

① Inch ports are standard ANSI B16.5 - compatible 150# raised face flanges. Metric dimension is for optional DIN 2501 - compatible PN 16/25/40 raised face flanges.

② 1 inch shaft is used with both ANSI and DIN flanges.

**DIMENSIONS – IEC M-DRIVE (DISPLACEMENT SIZES 01 & 02)**

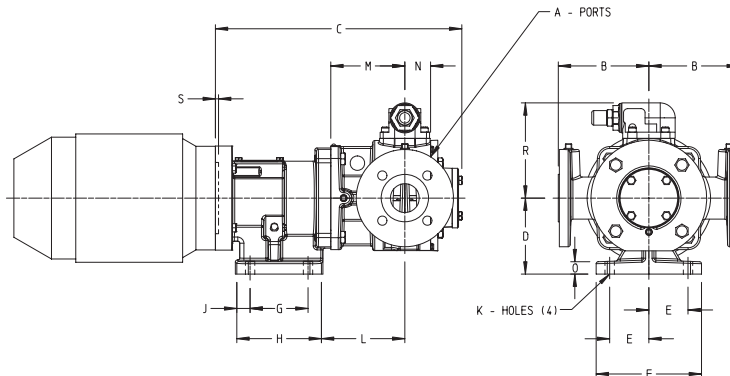

MODEL NO.		① A	B	M	N	R	MOTOR FRAME	C	D	E	F	G	H	J	K	L	O	S
LVP40017U	in	1.5	5.50	4.5	1.56	5.79	IEC 90	14.57	4.62	2.38	6.40	3.52	5.14	0.81	0.57	4.83	0.75	0.19
	mm	40	139.7	114.3	39.6	147.1		370.08	117.34	60.5	162.6	89.4	130.6	20.6	14.5	122.68	19.0	4.8
LVP40027U	in	1.5	5.50	4.5	1.56	5.79	IEC 100/112	14.97	4.62	2.38	6.40	3.52	5.14	0.81	0.57	4.98	0.75	0.19
	mm	40	139.7	114.3	39.6	147.1		380.24	117.34	60.5	162.6	89.4	130.6	20.6	14.5	126.5	19.0	4.8
	in	1.5	5.50	4.5	1.56	5.79	IEC 132	16.12	5.32	2.95	7.48	4.50	6.09	0.80	0.57	5.00	0.75	0.25
	mm	40	139.7	114.3	39.6	147.1		409.4	135.13	74.9	190.0	114.3	154.7	20.3	14.5	127.0	19.0	6.4

Brackets are designed for IEC motors with a B14 mounting face (non-footed motor).

Jaw type coupling with straight jaws recommended to facilitate assembly of motor and pump to bracket.

① Inch ports are standard ANSI B16.5 - compatible 150# raised face flanges. Metric dimension is for optional DIN 2501 - compatible PN 16/25/40 raised face flanges.

Coupling is guarded with a plate over the opening in the top of the bracket.

IEC brackets prior to 11/08 are different dimension - consult factory for drawing.

These dimensions are average and not for construction purposes. Certified prints on request.

# LIQUID-SPECIFIC PRODUCT LINE: STAINLESS STEEL VANE PUMPS

LVP SERIES™

Section	1761
Page	1761.7
Issue	A

## DIMENSIONS – NEMA M-DRIVE (DISPLACEMENT SIZES 01 & 02)

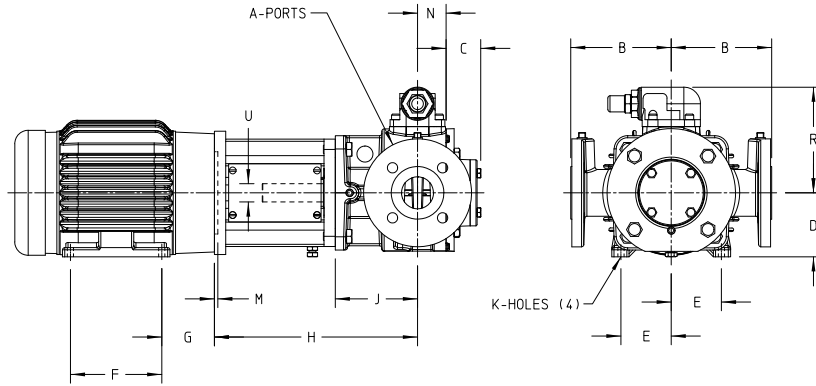

MODEL NO.		A	B	C	J	M	N	R	U	MOTOR FRAME	D	E	F	G	H	K
LVP40017U LVP40027U	in	1.50	5.50	1.90	4.50	0.19	1.56	5.79	1.00	56C	3.50	2.44	3.00	2.56	11.12	.34 SLOT
		1.50	5.50	1.90	4.50	0.19	1.56	5.79	1.00	143TC	3.50	2.75	4.00	2.88	11.12	0.34
		1.50	5.50	1.90	4.50	0.19	1.56	5.79	1.00	145TC	3.50	2.75	5.00	2.88	11.12	0.34
		1.50	5.50	1.90	4.50	0.19	1.56	5.79	1.00	182TC	4.50	3.75	4.50	3.44	11.81	0.41
		1.50	5.50	1.90	4.50	0.19	1.56	5.79	1.00	184TC	4.50	3.75	5.50	3.44	11.81	0.41
		1.50	5.50	1.90	4.50	0.19	1.56	5.79	1.00	213TC	5.25	4.25	5.50	4.31	12.56	0.41
		1.50	5.50	1.90	4.50	0.19	1.56	5.79	1.00	215TC	5.25	4.25	7.00	4.31	12.56	0.41

Bracket not footed. Use footed NEMA C motor.

Ports are ANSI B16.5 Compatible 150# class raised face flanges.

These dimensions are average and not for construction purposes. Certified prints on request.

Section	1761
Page	1761.8
Issue	A

**LIQUID-SPECIFIC PRODUCT LINE:  
STAINLESS STEEL VANE PUMPS  
LVP SERIES™**

**DIMENSIONS – FOOTED PUMP (DISPLACEMENT SIZES 01 & 02)**

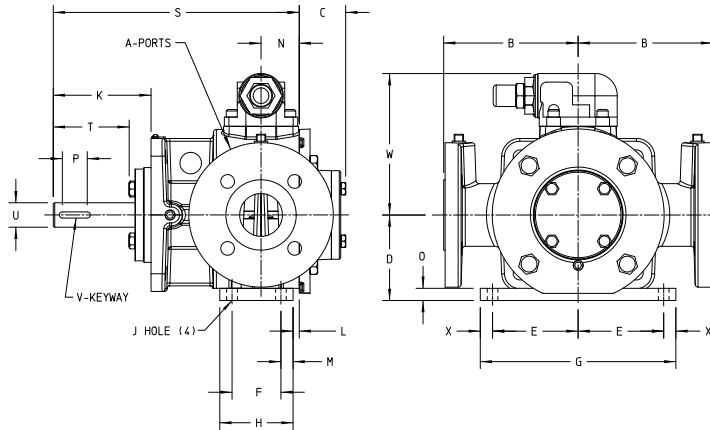

MODEL NO.		① A	B	C	D	E	F	G	H	J	K	L	M	N	O	P	S	T	② U	② V	W	X
LVP41017 LVP41027	in	1.50	5.50	1.90	3.50	3.50	2.00	8.00	3.00	0.44	4.00	0.25	0.50	1.56	0.50	1.02	10.06	3.11 / *1.63	1.00	.25 X .12	5.79	0.50
	mm	40	140	48	89	89	51	203	76	11	102	6	13	40	13	26	256	79 / *41	25.4	6.4 X 3.2	147	13

\* T dimension when using a cartridge seal.

① Inch ports are standard ANSI B16.5 - compatible 150# raised face flanges.  
Metric dimension is for optional DIN 2501 - compatible PN 16/25/40 raised face flanges.

② 1 inch shaft is used with both ANSI and DIN flanges.

**DIMENSIONS – D-DRIVE (DISPLACEMENT SIZES 01 & 02)**

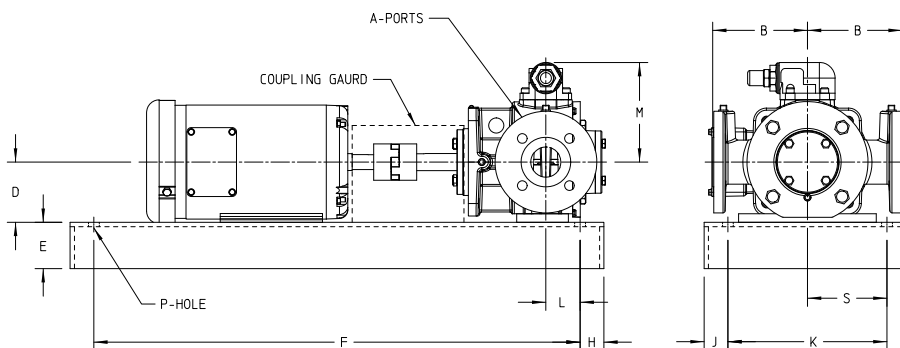

MODEL NO.	MOTOR FRAME		③ A	B	D	E	F	H	J	K	L	M	P	S
LVP41017U LVP41027U	56 -143T -145T	in	1.50	5.50	3.50	2.94	29.00	1.00	1.50	9.00	2.38	5.79	0.62	4.50
	182T - 184T				*4.50									
	213T - 215T				*5.25									
	90	mm	40	140	90	75	737	25	38	229	60	147	16	114
	100				*100									
	112				*112									
132	*132													

\* Dimension includes a block under the pump foot.

③ Inch ports are standard ANSI B16.5 - compatible 150# raised face flanges.  
Metric dimension is for optional DIN 2501 - compatible PN 16/25/40 raised face flanges.

These dimensions are average and not for construction purposes. Certified prints on request.

# LIQUID-SPECIFIC PRODUCT LINE: STAINLESS STEEL VANE PUMPS

LVP SERIES™

Section	1761
Page	1761.9
Issue	A

## DIMENSIONS – PUMP ONLY (DISPLACEMENT SIZES 05, 08, 19 & 23)

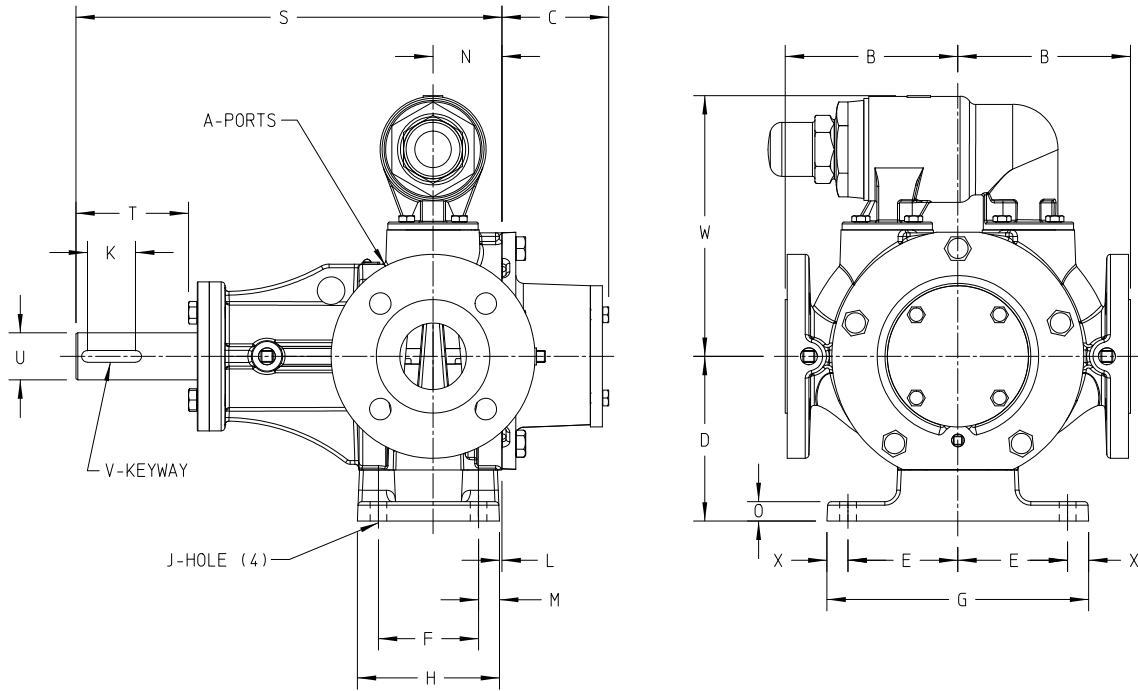

MODEL NO.	① A		B	C	D	E	F	G	H	J	K	L
LVP41057	2.00	in	5.50	3.40	5.25	3.50	3.19	8.34	4.53	0.53	1.53	0.08
LVP41087	50	mm	140	86	133	89	81	212	115	13	39	2
LVP41197	3.00	in	7.25	3.40	6.10	4.25	4.24	9.72	5.46	0.53	3.03	0.46
LVP41237	80	mm	184	86	155	108	108	247	139	13	77	12

MODEL NO.		M	N	O	S	T	② U	② V	W	X
LVP41057	in	0.67	2.20	0.62	13.58	3.59 / *2.06	1.50	.38 X .19	8.31	0.67
LVP41087	mm	17	56	16	345	91 / *52	38.1	9.5 X 4.8	211	17
LVP41197	in	0.61	3.04	0.62	16.76	5.09 / *3.56	1.50	.38 X .19	9.28	0.61
LVP41237	mm	15	77	16	426	129 / *90	38.1	9.5 X 4.8	236	15

\* T dimension when using a cartridge seal

① Inch ports are standard ANSI B16.5 - compatible 150# raised face flanges. Metric dimension is for optional DIN 2501 - compatible PN 16/25/40 raised face flanges.

② 1.5 inch shaft is used with both ANSI and DIN flanges.

These dimensions are average and not for construction purposes. Certified prints on request.

Section	1761
Page	1761.10
Issue	A

**LIQUID-SPECIFIC PRODUCT LINE:  
STAINLESS STEEL VANE PUMPS  
LVP SERIES™**

**DIMENSIONS – FOOTED D-DRIVE (DISPLACEMENT SIZES 05 & 08)**

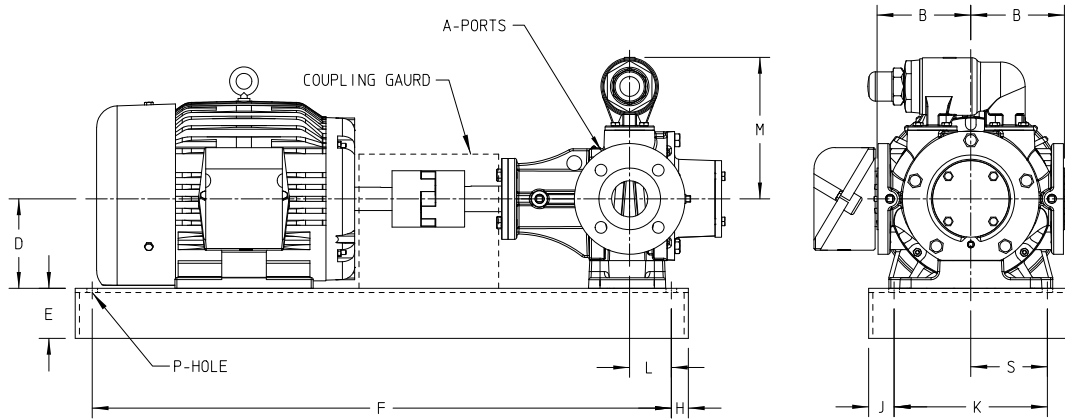

MODEL NO.	MOTOR FRAME		① A	B	D	E	F	H	J	K	L	M	P	S
LVP41057U LVP41087U	213T - 215T	in	2.00	5.50	5.25	2.94	34.00	1.00	1.50	9.00	2.45	8.31	0.62	4.50
	254T - 256T				*6.25	4.00	39.00	1.38	1.38	16.00	2.45	8.31	0.62	8.00
	284T - 286T				*7.00									
	132	mm	50	140	*133.4	75	864	25	38	229	62	211	16	114
	160				*180	102	991	35	35	406	62	211	16	203
	180				*200									

\* Dimension includes a block under the pump foot.

① Inch ports are standard ANSI B16.5 - compatible 150# raised face flanges. Metric dimension is for optional DIN 2501 - compatible PN 16/25/40 raised face flanges.

**DIMENSIONS – FOOTED R-DRIVE (DISPLACEMENT SIZES 19 & 23)**

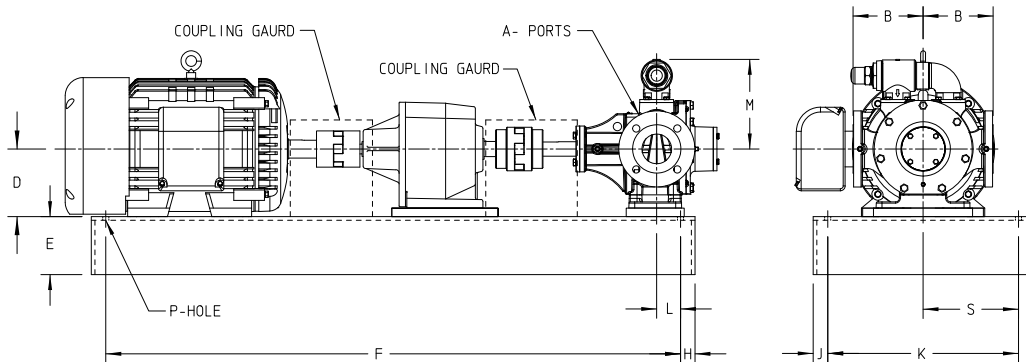

MODEL NO.	MOTOR FRAME		② A	B	D	E	F	H	J	K	L	M	P	S
LVP41197U LVP41237U	254T - 256T	in	3.00	7.25	*6.50	6.00	59.50	1.50	1.50	19.75	2.47	9.28	0.62	9.88
	284T - 286T				*7.00									
	324T - 326T				*8.00									
	160	mm	80	184	*161	152	1511	38	38	502	63	236	16	251
	180				*180									
	200				*200									

\* Dimension includes blocks under the pump and reducer. Blocks are used under the reducer, pump and motor are on the 254T - 256T frame sizes.

② Inch ports are standard ANSI B16.5 - compatible 150# raised face flanges. Metric dimension is for optional DIN 2501 - compatible PN 16/25/40 raised face flanges.

These dimensions are average and not for construction purposes. Certified prints on request.

**LIQUID-SPECIFIC PRODUCT LINE:  
STAINLESS STEEL VANE PUMPS  
LVP SERIES™**

Section	1761
Page	1761.11
Issue	A

**NPSH REQUIRED**

Printed performance curves are not available.

Performance curves can be electronically generated with the Viking Pump Curve Generator on [vikingpump.com](http://vikingpump.com).

NPSH<sub>R</sub> data is not available on the curve generator.

**NPSH (Net Positive Suction Head):** The NPSH<sub>R</sub> (Net Positive Suction Head Required by the pump) is given in the table below and applies for viscosities through 750 SSU. NPSH<sub>A</sub> (Net Positive Suction Head – Available in the system) must be greater than the NPSH<sub>R</sub>. For a complete explanation of NPSH, see Application Data Sheet AD-19.

**FOR VISCOSITIES UP TO 750 SSU –** See NPSH<sub>R</sub> table below.

**NPSH<sub>R</sub> for high viscosities can be estimated using the following method:**

1. Calculate line loss for a 1 foot long pipe of a diameter matching the pump inlet port size. Use your flow rate and max viscosity.
2. Convert this value into Feet of Liquid (S.G. 1.0)
3. Add this value to the NPSH<sub>R</sub> value in the chart below.

PUMP SIZE	PUMP SPEED, RPM														
	100	125	155	190	230	280	350	420	520	640	780	950	1150	1450	1750
01									4.7	5.3	6.1	7.3	9.0	12.3	16.4
02									4.7	5.3	6.1	7.3	9.0	12.3	16.4
05							6.2	6.9	8.0	9.8	12.4	16.3	21.9		
08							9.8	11.0	13.0	16.0	20.3	26.9			
19			3.2	3.4	3.8	4.5	5.9	8.0	12.5						
23			3.9	4.3	5.0	6.2	8.8	12.6	20.8						

**Note:** NPSH<sub>R</sub> – FEET OF LIQUID (Specific Gravity 1.0), Viscosities up to 750 SSU

1. NPSH<sub>A</sub> (Net Positive Suction Head Available) must be greater than the NPSH<sub>R</sub> (Net Positive Suction Head Required) given in the above table.
2. VISCOSITY - Above chart applies to viscosities up thru 100 SSU. Consult factory or Viking representative for viscosities above 100 SSU.
3. For liquids other than water, divide by specific gravity.



**0508 4 BBENG**  
**[www.brownbros.co.nz](http://www.brownbros.co.nz)**