

LIQUID-SPECIFIC PRODUCT LINE: CAST IRON ELECTRICALLY HEATED ASPHALT PUMPS

32E Series™

Section	1466
Page	1466.1
Issue	A

TABLE OF CONTENTS

Related Products	1
Operating Range.....	1
Series Description	1
Features & Benefits	2
Model Number Key	2
Standard Materials of Construction	2
Specifications: Unmounted Pumps.....	2
Pressure Relief Valves	3
Specifications: Electric Heat	3
Control System (<i>accessory not included with pump</i>)	3
Dimensions – Unmounted Pump	4
Dimensions – Heat Cartridge Locations	4
NPSH Required	5

RELATED PRODUCTS

Cast Iron, 124E Series™ & 324E Series™:
Catalog Section 1465

Cast Iron, 34 Series™: Catalog Section 1464

SERIES DESCRIPTION

Viking's 32E Series™ Asphalt Pumps melt ambient-temperature solids to a liquid state prior to pump startup using electric cartridge heaters with closed-loop control systems. This enables heating without the need for piping steam or hot oil to the pump. The 32E Series™ are available as packed pumps only.

Heat cartridges located on the head, and in some sizes the casing, provide sufficient heat to melt the liquid within the pump and at the stuffing box.

The pump user may provide their own temperature control system, or Viking Pump offers a controller for its electrically heated pumps. It is a closed loop PID control providing fast, effective time to temperature with minimal overshoot to prevent overheating. The control system includes a thermocouple and thermowell adapter for mounting to the pump and a controller which powers all the heat cartridges on one pump (N-size requires a separate 40-amp relay). The controller has a user adjustable temperature set point, up to a preset maximum. When the set point is reached, a relay can be wired to alert the operator, or prevent a pump from being started until the asphalt is melted. It can be ordered with pre-set maximum temperature of either 150°F, 250°F, 350°F or 450°F; or 65°C, 120°C, 175°C or 230°C.

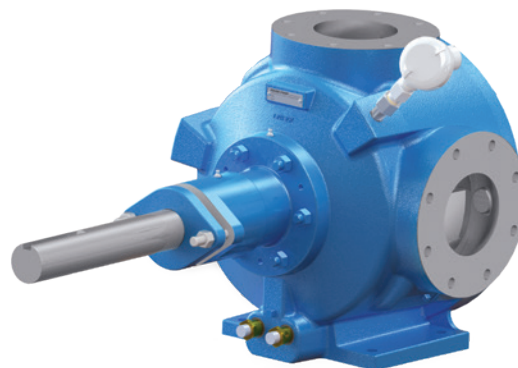

N32E

OPERATING RANGE

SERIES	NOMINAL FLOW		MAXIMUM PRESSURE		TEMPERATURE RANGE		VISCOSITY RANGE	
	GPM	m³h	PSI	Bar	°F	°C	SSU	cSt
32E Series™	90 - 450	20 - 102	100	7	-60 to +450	-50 to +230	28 to 25,000	.1 to 5,500

LIQUID-SPECIFIC PRODUCT LINE: CAST IRON ELECTRICALLY HEATED ASPHALT PUMPS

32E Series™

Section	1466
Page	1466.3
Issue	A

PRESSURE RELIEF VALVES

32E Series™ pumps feature a non-jacketed relief valve as standard. The heat cartridges in the head supply sufficient heat to melt asphalt in the relief valve as long as the pump is insulated. A plain head option is available.

All positive displacement pumps should have some form of pressure relief, whether in the pump or downstream of the pump, to prevent overpressure situations.

SPECIFICATIONS: ELECTRIC HEAT

Heat cartridges (pre-installed on pump)
All heaters are 240 VAC, 1 phase, 50/60 Hz

Model Number	Head Cartridges	Watts/ Cartridge (Head)	Casing Cartridges	Watts/ Cartridge (Casing)	Total Watts
LQ32E	2	350	2	250	1200
Q32E	3	500	0	-	1500
M32E	3	450	2	450	2250
N32E	2	900	2	350	2500

Materials:

Incoloy® outer sheath, PFA moisture seal, Brass NPT fitting

Leads:

Two - fiberglass-insulated leads rated to 842°F/450°C for temperature resistance (Lead lengths by size: LQ, 24"; Q, 118"; M, 84"; N, 84" and 118") in flexible stainless steel hose for abrasion resistance. Two leads extend 12- past end of SS hose. Normal practice is to wire all cartridges to local junction box at pump, with one cable to controller.

Agency Approvals:

UL, CSA, VDE, CE

CONTROL SYSTEM (ACCESSORY NOT INCLUDED WITH PUMP)

Thermocouple:

Type J thermocouple with thermowell in weather-resistant housing with ½" MNPT fitting to mount in pump.

Controller Specifications:

Enclosure:

1/16 DIN, NEMA 4X / IP66 for panel mount

Mains power:

240 VAC, 1 phase

Heater Output:

15A NO-ARC, Form A

Control Algorithm:

PID, with pre-set bandwidths

Set point Achieved Relay Output:

Mechanical relay, 5A, Form A

Agency Approvals:

UL, CSA, CE, RoHS, W.E.E.E., FM

N-size pump requires a separate 40-amp relay, available from Viking.

WARNING: Use National Electric Code (NEC) or other country-specific standard wiring and safety practices when wiring and connecting this controller to a power source and to electrical sensors, heaters or peripheral devices. Failure to do so may result in damage to the equipment and property, and/or injury or loss of life.

Electrically heated pumps should always be insulated, and if possible, use spacers between the pump foot and baseplate to minimize heat loss. Approximate time to temperature is 3 hours for a 300 degree temperature rise.

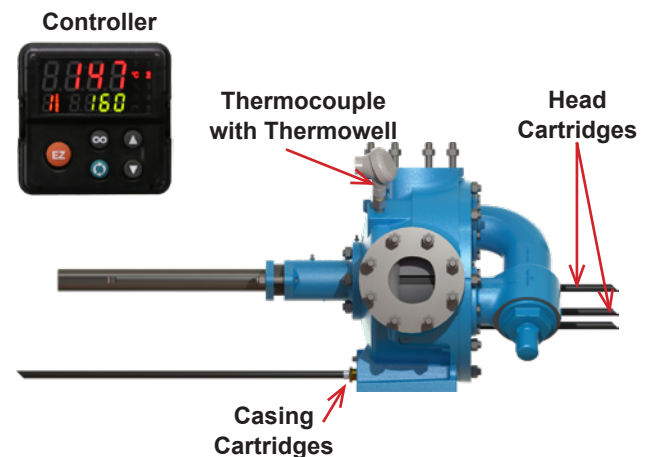

Section	1466
Page	1466.4
Issue	A

**LIQUID-SPECIFIC PRODUCT LINE:
CAST IRON ELECTRICALLY HEATED ASPHALT PUMPS
32E Series™**

DIMENSIONS – UNMOUNTED PUMP

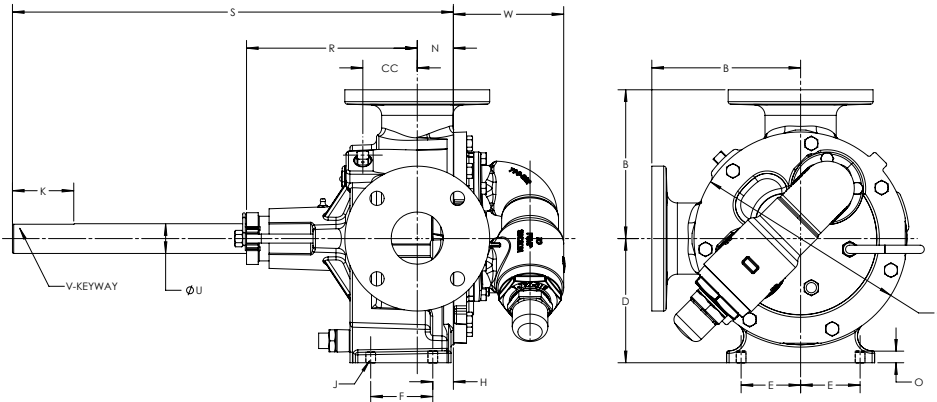

Model Number		① A	B	C	CC	D	E	F	H	J	K	N	O	② R	S	U	V	W
LQ32E	in	2½	7.19	10.25	2.63	6.00	2.88	3.00	1.00	.47	3.00	1.75	.50	9.88	21.25	1.44	.375 x .19	5.38
	mm		183	260	67	152	73	76	25	12	76	44	13	251	552	37		137
Q32E	in	3	7.75	14.00	3	7.75	4.13	4.25	1.63	.69	5.00	3.00	.63	13.88	33.50	1.94	.50 x .25	8.19
	mm		197	356	76	197	105	108	41	18	127	76	16	353	851	49		208
M32E	in	4	9.50	17.25	2.75	9.50	5.00	6.25	1.44	.69	5.00	4.00	.75	13.38	34.00	1.94	.50 x .25	8.5
	mm		241	438	70	241	127	159	37	18	127	102	19	340	864	49		216
N32E	in	5	9.50	17.25	5.25	9.50	5.00	6.25	1.63	.69	5.00	4.50	1	20.88	34.00	2.44	.625 x .3125	8.25
	mm		241	438	133	241	127	159	41	18	127	114	25	530	864	62		216

① Ports are suitable for use with 125# ANSI cast iron flanges or 150# steel or ductile iron companion flanges or flanged fittings.

② Minimum dimension for repacking.

DIMENSIONS – HEAT CARTRIDGE LOCATIONS

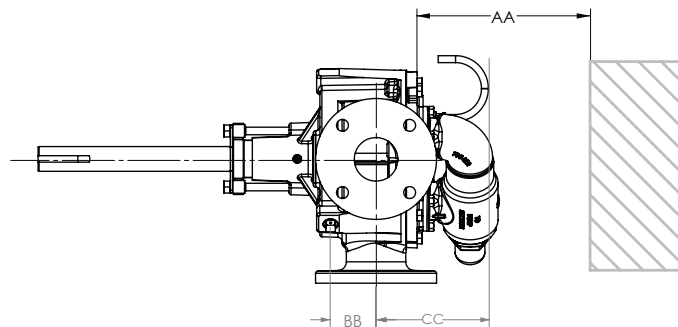

Model Number	Temp Probe to Port Center Line (BB)		Head Heater to Port Center Line (CC)		Required to Remove Heater (AA)	
	Inch	mm	Inch	mm	Inch	mm
LQ32E	2.54	64.5	5.75	146.1	7.00	177.8
Q32E	2.85	72.4	8.25	209.6	9.25	234.95
M32E	2.64	67.1	8.25	209.6	9.25	234.95
N32E	5.05	128.2	8.25	209.6	9.25	234.95

LIQUID-SPECIFIC PRODUCT LINE:
CAST IRON ELECTRICALLY HEATED ASPHALT PUMPS
 32E Series™

Section	1466
Page	1466.5
Issue	A

NPSH REQUIRED

Printed performance curves are not available.

Performance curves can be electronically generated with the Viking Pump Curve Generator on vikingpump.com.

NPSH_R data is not available on the curve generator.

NPSH (Net Positive Suction Head): The NPSH_R (Net Positive Suction Head Required by the pump) is given in the table below and applies for viscosities through 750 SSU. NPSH_A (Net Positive Suction Head – Available in the system) must be greater than the NPSH_R. For a complete explanation of NPSH, see Application Data Sheet AD-19.

FOR VISCOSITIES UP TO 750 SSU – See NPSH_R table below.

NPSH_R for high viscosities can be estimated using the following method:

1. Calculate line loss for a 1 foot long pipe of a diameter matching the pump inlet port size. Use your flow rate and max viscosity.
2. Convert this value into Feet of Liquid (S.G. 1.0)
3. Add this value to the NPSH_R value in the chart below.

PUMP SIZE	PUMP SPEED [RPM]														
	100	125	155	190	230	280	350	420	520	640	780	950	1150	1450	1750
LQ	1.7	1.8	2.0	2.2	2.5	3.0	3.8	5.0	7.3	10.8	—	—	—	—	—
Q	1.9	2.1	2.3	2.7	3.3	4.2	6.1	8.4	12.7	—	—	—	—	—	—
M	2.1	2.3	2.8	3.4	4.3	6.0	9.0	12.7	—	—	—	—	—	—	—
N	2.1	2.5	3.5	4.5	6.3	9.5	15.0	—	—	—	—	—	—	—	—

Note: NPSH_R – FEET OF LIQUID (Specific Gravity 1.0), Viscosities up to 750 SSU



0508 4 BBENG
www.brownbros.co.nz