



English

Original Instructions

Installation, Operation and Maintenance Instructions

SB Muncher

Spares & Service Contact Details

Mono UK

Spares	+44 (0)161 214 2380 (direct line 8.15 am – 5.00 pm)
E-mail	spares@mono-pumps.com
Service	+44 (0)161 214 2390 (direct line 8.15 am – 5.00 pm)
E-mail	customerservices@mono-pumps.com
Service	+44 (0)161 339 9000 (24 hrs)

Mono Australia

	Telephone	Facsimile
Melbourne	(03) 9580 5211	(03) 9580 9036
Sydney	(02) 9521 5611	(02) 9542 3649
Brisbane	(07) 3350 4582	(07) 3350 3750
Adelaide	(08) 8447 8333	(08) 8447 8373
Perth	(08) 9479 0444	(08) 9479 0400
Darwin	(08) 8984 3099	(08) 8947 0540
Tasmania	0417 345 814	(03) 6330 2051
E-mail	ozsales@mono-pumps.com	

Mono New Zealand

Spares & Service	+64 (0)9 829 0333
E-mail	info@mono-pumps.co.nz

Monoflo USA

Spares & Service	+1 713 466 7999
E-mail	inquire@monoflo.com

Monoflo South America

Spares & Service	+54 4296 8997	+54 4284 0323
E-mail	inquire@monoflo.com	

Mono China

	Telephone	Facsimile
Beijing	+86 (0) 10 6461 1115	+86 (0) 10 8486 8481
Shanghai	+86 (0) 21 5915 7168	+86 (0) 21 5915 6863
E-mail	monoshanghai@nov.com	

Tools

For servicing and maintenance work on the Muncher the following tools are recommended.

SB Muncher:

Metric Hexagon Keys - Range 6mm-8mm
Metric Spanners - Range 10mm-36mm
Torque Wrench

Series A Muncher:

Metric Hexagon Keys - Range 6mm-8mm
Metric Spanners - Range 10mm-36mm
Torque Wrench

Series F Muncher:

Metric Hexagon Keys - Range 6mm-8mm
Metric Spanners - Range 10mm-36mm
Torque Wrench
Mono Locknut Key - Item No.s MQ F06A 9750, CF F06A 9755 and MM F06A 9760

TR Muncher:

Metric Hexagon Keys - Range 6mm-14mm
Metric Spanners - Range 10mm-36mm
Torque Wrench

Series R Muncher:

Metric Hexagon Keys - Range 5mm-14mm
Metric Spanners - Range 10mm-36mm
Torque Wrench

All equipment should be in good working condition with no signs of excessive wear.

ATEX Warning Statements

GRINDERS

Due to the nature and design of grinding and macerating equipment it is possible that certain objects may enter the cutters, from the process stream, with the potential to cause sparking or jamming of the cutter assembly.

Where a grinder unit is to be installed in a potentially explosive atmosphere ensure that this has been specified at the time of purchase and that the equipment has been supplied accordingly and displays an ATEX nameplate or is supplied with a certificate of conformity. If there is any doubt as to the suitability of the equipment please contact Mono Pumps Limited before commencing with installation and commissioning.

Process liquids or fluids should be kept within specified temperature limits otherwise the surface of grinder or system components may become an ignition source due to temperature rises. Where the process liquid temperature is less than 90°C the maximum surface temperature will not exceed 90°C provided the grinder is installed, operated and maintained in accordance with this manual. Where the process fluid temperature exceeds 90°C the maximum surface temperature will be equal to the maximum process fluid temperature.

Cavities that could allow the accumulation of explosive gases, such as under guards, should where possible, be designed out of the system. Where this is not possible they should be fully purged before any work is carried out on the grinder or system.

Electrical installation and maintenance work should only be carried out by suitably qualified and competent persons and must be in accordance with relevant electrical regulations.

All electrical equipment, including control and safety devices, should be suitably rated for the environment in to which they are installed.

Where there may be a risk of an accumulation of explosive gases or dust non-sparking tools should be used for installation and maintenance.

To minimise the risk of sparking or temperature rises due to mechanical or electrical overload the following control and safety devices should be fitted. A control system that will shut the grinder down if the motor current or temperature exceed specified limits or a jam of the cutter stack occurs. This may include a system that reverses the machine in order to clear any such jam. An isolator switch that will disconnect all electrical supply to the motor and ancillary electrical equipment and be capable of being locked in the off position. All control and safety devices should be fitted, operated and maintained in accordance with the manufacturer's instructions.

It is important that the grinder rotates in the correct direction to give an efficient grinding operation. This must be checked on installation and commissioning and after any maintenance has been carried out. Failure to observe this may lead to mechanical or electrical overload.

When fitting drives, couplings, and guards to a grinder unit it is essential that these are correctly fitted, aligned and adjusted in accordance with the O&M instructions. Failure to do so may result in sparking due to unintended mechanical contact or temperature rises due to mechanical or electrical overload.

Mechanical seals should be suitably rated for the environment. The seal and any associated equipment, such as a flushing system, must be installed, operated and maintained in accordance with the manufacturer's instructions.

ATEX Warning Statements

Where a packed gland seal is fitted this must be correctly fitted and adjusted. This type of seal relies on the process liquid to cool the shaft and packing rings so a constant drip of liquid from the gland section is required. Where this is undesirable an alternative seal type should be fitted.

Failure to operate or maintain the grinder and ancillary equipment in line with the manufacturer's instructions may lead to premature and potentially dangerous failure of components. Regular inspection, and where necessary replacement, of bearings, seals, other wearing parts and lubrication is essential.

The grinder and its components have been designed to ensure safe operation within the guidelines covered by legislation. Accordingly Mono Pumps Limited have declared the machine safe to use for the duty specified as defined by the Declaration of Incorporation or Conformity that is issued with this instruction manual. The use of replacement parts that are not manufactured by or approved by Mono Pumps Limited may affect the safe operation of the grinder and it may therefore become a safety hazard to both operators and other equipment. In these circumstances the Declaration provided will become invalid. The guarantee referenced on the Terms and Conditions of Sale will also be invalidated.

Introduction

SB Muncher

This information and all the information contained herein, are the exclusive property of Mono Pumps Ltd, and contain information of a proprietary nature. It is provided for the sole purpose of transmitting the information contained to the designated recipient.

This information is to be used only as specified in the instrument of transmittal. It is not to be reproduced, copied in whole, or in part, nor is information it contains to be disclosed in any manner without the written consent of Mono Pumps Ltd. Its use for any other reason than the specified shall be a violation of the agreement with the recipient concerning the legal rights of Mono Pumps Ltd.

Mono Pumps Ltd reserves the right to make changes, which may obsolete certain parts of this manual.

The manual gives a guide to the operation and maintenance of the SB Muncher given that all Health and Safety and good engineering practices are observed.

The information below is for contract No. _____
supplied.

and gives the duty for which the equipment is

 The Muncher®	WARNING
MODEL No. <input type="text"/>	ENSURE THIS MACHINE IS
CONTRACT No. / Date <input type="text"/>	ELECTRICALLY ISOLATED AND
DUTY / LIQUID <input type="text"/>	CANNOT BE STARTED PRIOR TO
Martin Street, Audenshaw, Manchester M34 5DQ	REMOVING ANY FITMENT, GUARD OR
Tel : 0161 339 9000 Fax : 0161 344 0727	INSPECTION COVER AND THAT ALL
www.mono-pumps.com	ITEMS SO REMOVED ARE REPLACED
MADE IN ENGLAND	PRIOR TO RESTARTING.

Index

SECTION 1	INSTALLATION
SECTION 2	START-UP PROCEDURE
SECTION 3	DISMANTLING AND ASSEMBLY ADVICE
SECTION 4	WIRING DIAGRAM
	DRAWING REF. No.'s and TORQUE DATA
	CODING TABLE
SECTION 5	DISMANTLING AND ASSEMBLY DIAGRAMS
SECTION 6	EXPLODED VIEW
SECTION 7	SECTIONAL ARRANGEMENTS
SECTION 8	GENERAL ARRANGEMENTS
SECTION 9	LIFTING AND GUARDING DIAGRAMS

EC Declaration as defined by Machinery Directive 2006/42/EC.

The following harmonised standards are applicable: BS EN 809, BS EN ISO 12100 Parts 1 & 2

EC Declaration of Incorporation

This declaration is only valid when partly completed machinery has been supplied.

In this case, the machinery meets the requirements of the said directive and is intended for incorporation into other machinery or for assembly with other machinery in order to constitute relevant machinery as defined by the said directive including any amendments, which are valid at the time of supply.

IMPORTANT

This machinery must not be put into service until the relevant machinery into which it is to be incorporated has been declared in conformity to the said directive.

This declaration is only valid when the machinery has been installed, operated and maintained in accordance with these instructions and safety guidelines contained within as well as instructions supplied for equipment assembled with or intended for use with this equipment.

EC Declaration of Conformity

This declaration is not valid for partly completed machinery has been supplied.

In this case the machinery meets the requirements of the said directive including any amendments which are valid at the time of supply.

We further declare that, where applicable, said machinery also meets the requirements of:

The EMC Directive 2004/108/EC
The Low Voltage Directive 2006 /95/E
The Pressure Equipment Directive 97/23/EC
The Outdoor Noise Directive 2005/88/EC
The Drinking Water Directive 99/83/EC

IMPORTANT

This declaration is only valid when the machinery has been installed, operated and maintained in accordance with these instructions and safety guidelines contained within as well as instructions supplied for equipment assembled with or intended for use with this equipment.



**Mr C. Q. Griffiths - Engineering Services Manager.
for Mono Pumps Limited, Martin Street, Audenshaw,
Manchester England, M34 5JA**

Installation, Operation & Maintenance Instructions

1.0 INSTALLATION

1.1 INSTALLATION & SAFETY RECOMMENDATIONS

In common with other items of process plant a Muncher must be installed correctly to ensure satisfactory and safe operation. The Muncher must also be maintained to a suitable standard. Following these recommendations will ensure that the safety of personnel and satisfactory operation of the Muncher is achieved.

1.1.1 OPERATING PRINCIPLE

The Muncher

The Muncher is a slow speed, high torque grinder designed to operate in the water, waste and bio-waste industries. All Munchers have two shafts operating at differential speeds. Each shaft is fitted with identical interleaving cutters and spacers.

1.2 GENERAL

When handling harmful or objectionable materials, adequate ventilation must be provided in order to disperse dangerous concentrations of vapours. It is recommended that wherever possible, Mono Munchers should be installed with provision for adequate lighting, thus ensuring that effective maintenance can be carried out in satisfactory conditions. With certain product materials, a hosing down facility with adequate draining will simplify maintenance and prolong the life of the Muncher components.

1.3 SYSTEM DESIGN AND INSTALLATION

At the system design stage, consideration must be given to the provision of filler plugs, and the installation of non-return and/or isolating valves where applicable.

Series 'F' AND 'H' Munchers are horizontal dry waste machines and must be fixed rigidly and horizontally either to the ground, or to a rigid system.

TR Pipeline models are designed for horizontal installation only.

Series 'A', SB and 'R' open channel models do not require fixing to the ground and can be supported either by the concrete channel or by steel supports bolted to the concrete channel walls.

Series 'A', SB and 'R' pipeline models can be installed at any attitude.

Pipework to and from the unit should be independently supported and not rely on the Muncher as a means of support. Wherever possible when installed in a vertical pipe system the Muncher unit should be independently supported.

1.4

HANDLING



During installation and maintenance, attention must be paid to the safe handling of all items. Where a Muncher or its components weigh in excess of 20kg (45lb) it is recommended that suitable lifting tackle should be used to ensure that personal injury or damage to components does not occur.

A weight table is included at the end of this section.

Lifting illustrations are contained in this document -Section 8.

NOTE

DO NOT ATTEMPT TO LIFT MUNCHER USING ONLY ONE LIFTING LUG. EXTREME CAUTION SHOULD BE OBSERVED FOR PERSONNEL SAFETY WHEN LIFTING HEAVY OBJECTS.

BY DESIGN THE CUTTERS HAVE SHARP EDGES. GREAT CARE MUST BE TAKEN WHEN HANDLING. THE USE OF PROTECTIVE GLOVES IS RECOMMENDED.

1.5

STORAGE

Munchers are despatched from our factory with the cutter chamber sprayed with a moisture repellent coating and ready for immediate installation and operation.

Should the machine be stored or left stationary for any length of time it is recommended that the cutter bank is re-sprayed with anti-rust lubricant and that the shafts are rotated monthly.

Removing the motor cowl and turning the fan by hand is the easiest way to rotate the shafts.

Failure to do this may result in a higher frequency of reversals and in extreme cases the machine to seize due to the tight running clearances of the individual cutting elements during commissioning and initial start-up.

The starter panel if supplied should be stored in a controlled dry environment to prevent moisture build-up causing corrosion of contactors and other metallic components.

Installation, Operation & Maintenance Instructions

See manufacturer instructions for motor/gearbox/drive and panel storage procedures.

NOTE:



The Muncher must be protected by a PLC control unit set up to the correct operating philosophy. Only PLC's supplied or approved by Mono Pumps Limited should be used. Failure to observe this requirement may cause premature machine failure and could invalidate the warranty of the machine. It is also important that the PLC be correctly wired into the panel.

Please refer to Wiring Diagram – Section 4, Page 1.



IMMEDIATELY PRIOR TO INSTALLATION AND STARTING

Before installing the Muncher please ensure that all plugs and inspection plates are replaced.

1.6 ELECTRICAL

Electrical connection should only be made using equipment suitable for both rating and environment. Where any doubts exist regarding the suitability of equipment. Mono Pumps Limited should be consulted before proceeding.



Earthing points will be provided on electric drives (if supplied) and it is essential that these are correctly connected. The electrical installation should include appropriate isolating equipment to ensure that the unit is safe to work on.

1.7 GENERAL SAFETY



GREAT CARE MUST BE TAKEN TO PROTECT ALL ELECTRICAL EQUIPMENT FROM SPLASHING WHEN HOSING DOWN. WHERE MONO PUMPS LIMITED HAVE SUPPLIED A BASIC MUNCHER THE ONUS IS ON THE USER TO FIT ADEQUATE GUARDS IN COMPLIANCE WITH THE REQUIREMENTS OF THE RELEVANT REGULATIONS.



All nuts and bolts, securing flanges and base mounting fixtures must be checked for tightness before operation. When commissioning the plant, all joints in the system must be checked thoroughly for leakage.

If, when starting, the Muncher does not appear to operate correctly, the plant must be shut down immediately and the cause of the malfunction established before operations are recommenced.

May contain substances from the ECHA SVHC Candidates List (REACH - Regulation (EC) No. 1907/2006)

NOTE:

NEVER inspect or work on or near the cutter chamber without first isolating and locking the machine.

GUARDS



In the interests of safety, and in accordance with relevant legislation, all guards must be replaced after necessary adjustments have been made.



It is strongly recommended that a Series 'F' or 'H' horizontal dry Muncher system should incorporate: -

- A steel (or similar) feed hopper with a minimum base to top height of 1.0 metre or a minimum height of 1.5 metres from floor level.
- A steel (or similar) lower delivery chute, which is inaccessible without tools.
- A protective grid mounted over the Muncher and conveyor system, especially where overhead walkways are present.
- Emergency stop buttons positioned within easy reach of all operating staff.

The recommended extent of enclosure is illustrated in this document - Section 8.

1.7.1 WARNING /CONTROL DEVICE

Prior to operating the Muncher, if any warning or control devices are fitted these must be set in accordance with their specific instructions.

1.7.2 NOISE LEVELS

The noise sound pressure level will not exceed 70dB at one metre distance from the Muncher. This is based on a typical installation and does not necessarily include noise from other sources or any contribution from building reverberation.

1.8 EXPLOSIVE PRODUCTS/ HAZARDOUS ATMOSPHERES



In certain instances the product being treated may well be of a hazardous nature.

In these installations consideration must be given to provide suitable protection and appropriate warnings to safeguard personnel and plant.

Installation, Operation & Maintenance Instructions

1.9 LUBRICATION

The gearmotor(s) is supplied with the correct type and quantity of lubricant in the gearbox but should be checked before use. For further data see separate information supplied by manufacturer.

Series 'F' and 'H' bearings and rotary shaft seals are lubricated via greasing points on each bearing housing. The correct quantity of grease is reached when excess can be seen around the outer lipseal. Other models have sealed for life bearings that do not require maintenance.

Gears should be inspected periodically to see if grease replenishment is necessary, and if so, grease should be added via the grease nipple until the housing is two thirds full.

Only use recommended lubricant shown below for Muncher shaft gears, bearings and rotary seals.

BP Energrease LC2 (-30°C to 180°C).

At the following intervals, bearings, gears and seal assembly inspection should take place along with lubricant replenishment;

Series 'F', 'H', 'R' - 7,500 hrs

Series 'A', SB, TR - 10,000 hrs



PIPELINE MUNCHERS SHOULD BE ISOLATED BY CLOSING LINE VALVES PRIOR TO SERVICING.

Under tropical or other arduous conditions, however, more frequent lubrication may be necessary. It is therefore advisable to establish a suitable maintenance schedule or periodic inspection to match service conditions.

Weights

Muncher	Type	Gear Unit / Class	M/C Size (kW)	Weight (kg)	
Series A	CA202AA	IP55	1.5	241	
	CA203AA			251	
	CA205AA			276	
	CA206AA			286	
	CA210AA			351	
	CA215AA			400	
	CA202AB			IP55	2.2
	CA203AB	264			
	CA205AB	284			
	CA206AB	294			
	CA210AB	369			
	CA215AB	439			
	CA202AC	IP55	4.0	265	
	CA203AC			275	
	CA205AC			295	
	CA206AC			305	
	CA210AC			380	
	CA215AC			450	
	Series F			CF306RJS7B2	Nord IP55
		CF310RMS7B2	7.5 & 11	1180	
	Series H	CH06	Nord IP55	11 & 15 /15 & 22	1800
CH09		2300			
CH12		2800			
SB	Pipeline CB201	IP55	1.1	205	
			1.5	207	
			2.2	244	
		IP55	1.1	208	
			1.5	244	
			2.2	248	
	Channel CB201A	IP55	1.1	155	
			1.5	190	
			2.2	195	
		IP67 & 68	1.1	200	
			1.5	225	
			2.2	260	
TR	CT201D	IP55	1.5	175	
			2.2	180	
	CT203C	IP55	1.5	290	
			2.2/4.0	340	
	CT203D	IP55	1.5	290	
			2.2/4.0	340	
	CT203E	IP55	1.5	290	
2.2/4.0			340		
CT205F	IP55	1.5	345		
		2.2/4.0	390		
CT205G	IP55	1.5	345		
		2.2/4.0	390		
R	CR145A	IP55	7.5	800	

Installation, Operation & Maintenance Instructions

2.0 START-UP PROCEDURE



By the nature of the equipment and its operating environment the Muncher can be an extremely dangerous machine. It is vital that operators are conversant with these Operation and Maintenance Instructions prior to working with the machine.

Where applicable:

- 1) Check the foundation bolts are secure once the machine is installed in its correct operating position.
- 2) Check the gearbox lubricant, remove the plug and fit the air vent to prevent gearbox pressurisation. Not applicable to submersible drive units.
- 3) Check all electrical connections for continuity and earthing and that installation is in accordance with relevant regulations and circuit diagrams.
- 4) If a feed hopper is fitted, check that it is secure and installed correctly, and that no personnel can gain access to the moving parts of the machine.
- 5) Always ensure that machine is guarded in accordance with PD5304: 2000 Safety of Machinery requirements before any attempt is made to operate.
- 6) On start-up check the direction of rotation of the cutters. The cutters should rotate towards the centre when viewed from the inlet side.



NOTE:

If it is necessary to remove any inspection cover to observe the action – EXTREME CARE should be observed when carrying out this procedure.

- 7) Check that the Muncher stops when "STOP" button(s) are activated.
- 8) Check for reverse rotation of cutters when "REVERSE" button is activated.
- 9) Start up the machine. On initial start-up, allow machine to run for approximately 45 minutes.

- 10) Start the feed system to the machine. Care should be taken not to overburden the machine. Adjust feed to maintain only the smallest practical reservoir of material in cutter banks.
- 11) After a further 10 minutes of running, stop the machine, switch off and lock the main isolator. Check the tightness of all securing bolts. Re-check every 500 hours of operating time.
- 12) Check the tightness of all cables and connections. Re-check every 500 hours of operating time.
- 13) Observe manufacturers guidelines with regard to gearbox lubricant initial renewal and subsequent intervals.
- 14) In the event of machine overload (jam), the controller is programmed to activate the following procedure:-
 - i) Momentarily reverse rotation to clear the condition, then return to normal operation.
 - ii) If overload re-occurs within 60 seconds, reverse rotation to clear the condition, then return to normal operation.
 - iii) If a third overload occurs within 60 seconds of the first, machine shutdown in reverse mode and energise alarm circuit.
- 15) After machine shutdown, isolate and lock off. Inspect machine, removing any obstruction and press the "RESET" button.
- 16) The machine can now be re-started as 9) above.

NOTE:



NEVER inspect or work on or near the cutter chamber without first isolating and locking the machine.

Installation, Operation & Maintenance Instructions

3.0 DISMANTLING AND ASSEMBLY

Section 3 contains the steps to dismantle and re-assemble the Muncher. All fastenings must be tightened securely and where identified the appropriate torque figures should be used.

3.1 USE OF ITEMS NOT APPROVED OR MANUFACTURED BY MONO PUMPS LIMITED

The Muncher and its components have been designed to ensure that the machine will operate safely within the guidelines covered by the legislation.

As a consequence Mono Pumps Limited have declared the machine safe to use for the duty specified as defined by the Declaration of Incorporation or Conformity that is issued with this Instruction Manual.

The use of replacement items that are not approved by or manufactured by Mono Pumps Limited may affect the safe operation of the machine and it may therefore become a safety hazard to both operators and other equipment. In these instances the Declaration provided will therefore become invalid. The guarantee referenced in the Terms and Conditions of Sale will also be invalidated if replacement items are used that are not approved or manufactured by Mono Pumps Limited.

3.2 DISMANTLING ADVICE

(Refer to specified drawings).

CAUTION: When servicing the Muncher, be certain that the mains isolator is off and padlocked. Serious injury could result from accidental start-up.

- 1) Disconnect wiring at motor(s) terminal box(es) and tag leads for identification.
- 2) Pipeline models - Isolate the Muncher pipeline by closing line valves before and after the machine.
- 3) If necessary, the Muncher may be completely removed from installation using the recommended lifting equipment.
- 4) Pipeline models - Replace the pull back assembly with the maintenance period screen (MPS) if required.
- 5) When dismantling cutters and spacers, take careful note of the position and orientation of each component.

3.3 CLEANING / INSPECTION

- 1) Steam clean and disinfect all parts of the Muncher excluding motor, seal assemblies, gear drive unit and bearings.
- 2) Remove any gasket material from joint faces.
- 3) Housings should be cleaned thoroughly.
- 4) Inspect all parts for excessive wear and replace if necessary.
- 5) Sealed bearings cannot be re-greased, replace if necessary.
- 6) Check and if necessary replace the internal 'O'-rings, lipseals and mechanical seals.
- 7) Inspect gears for wear and damage and replace if necessary.
- 8) All cutters and spacers must be clean and free from cracks or excessive wear.
- 9) Shafts should be clean and any burrs filed off for easier stacking. Inspect shafts for excessive wear of hexagonal portion. Replace if necessary.

3.4 REASSEMBLY ADVICE

- 1) Lubricate all bores, shafts and seals on re-assembly.
- 2) Lubricate gears on re-assembly with the specified lubricant.
- 3) Reconnect wiring at motor(s) terminal box(es) using tag leads for identification.
- 4) Re-open system isolation valves.
- 5) On completion of assembly, run through the 'initial start-up' procedure in section 2.

Wiring Diagram

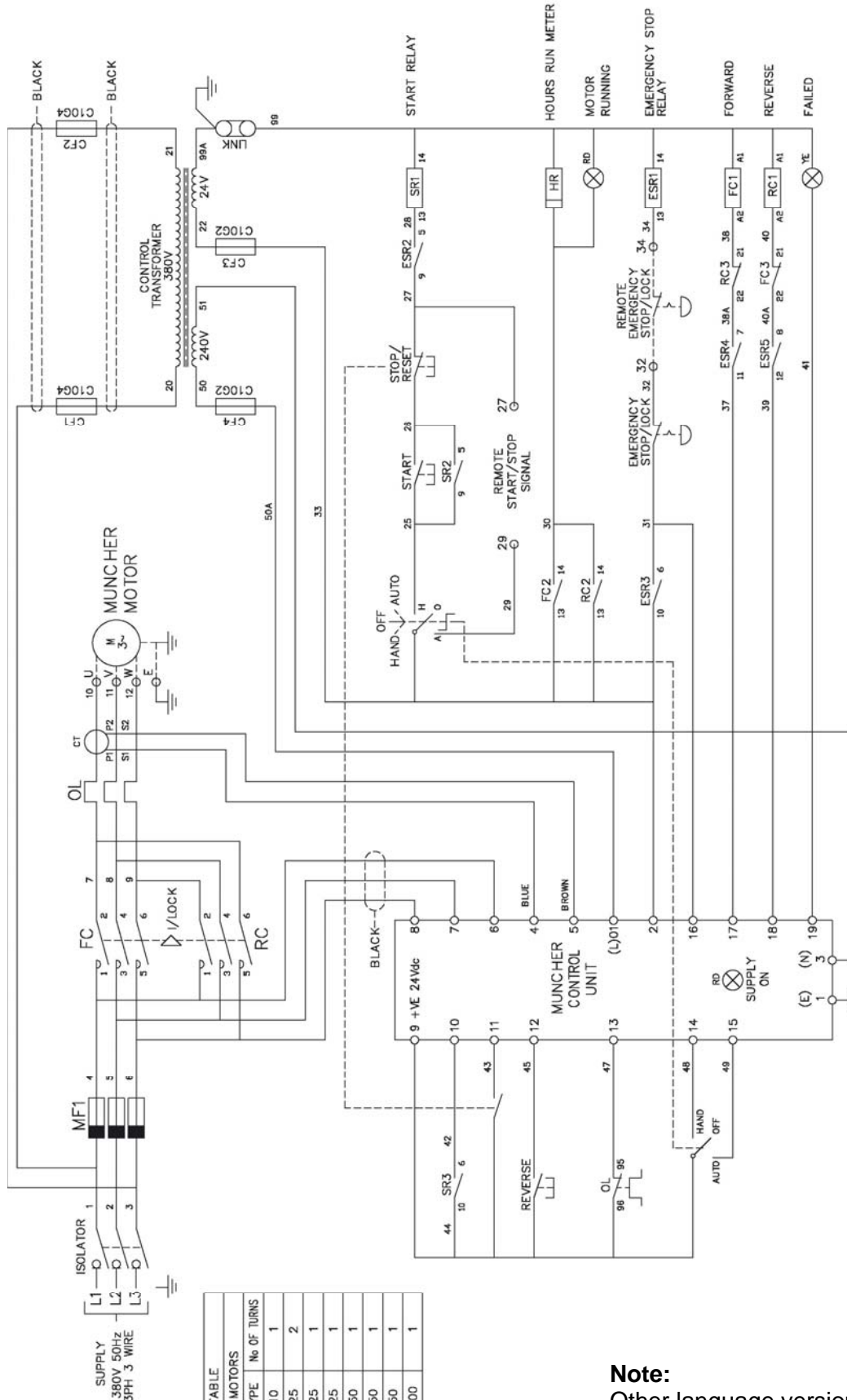

DRAWING No. A3/EMCP/K/ENG

Note:

Other language versions may be available on request. Please contact Mono Pumps.

Drawing Reference Numbers

<u>DRG.REF.</u>	<u>DESCRIPTION</u>	<u>DRG.REF.</u>	<u>DESCRIPTION</u>
0600	MUNCHER NAMEPLATE	P014	MECH SEAL
0650	WARNING NAMEPLATE	P017	BEARING
1150	TOP COVER PLATE	P018	LIPSEAL
1700	ADAPTOR STOOL	P019	55mm RECT PAR KEY
2000	COVER PLATE GASKET (TOP)	P020	36mm RECT PAR KEY
2500	CUTTER	P021	DOWEL PIN
2600	MUNCHER HALF COUPLING	P022	40mm EXTERNAL CIRCLIP
2626	GEAR HALF COUPLING	P023	35mm EXTERNAL CIRCLIP
3200	DRIVE SHAFT	P024	70mm INTERNAL CIRCLIP
3250	DRIVEN SHAFT	P025	DRIVESCREW
3500	CUTTER SPACER	P028	SLOTTED HEX NUT
4700	BACK UP WASHER	P029	SPLIT PIN
4702	WASHER	P030	M8 HEX HEAD SCREW
4750	CUTTER LOCKING RING	P031	M8 SOCKET CAP SCREW
7800	DRIVE GEAR	P033	M8 SPRING WASHER
7850	DRIVEN GEAR	P200	M10 HEX HEAD SCREW
		P201	M8 SOCKET SET SCREW
		P202	M12 HEX HEAD BOLT
		P204	M12 NUT
		P205	M10 SPRING WASHER
		P206	M12 PLAIN WASHER
		P207	M12 SPRING WASHER

Channel Models Only		Pipeline Models Only	
0100	BEARING HOUSING	0300	MAIN BODY
2150	SIDERAIL AND BOTTOM HSNQ.	1100	BOTTOM COVER PLATE
9700	LIFTING LUG	2000B	COVER PLATE GASKET (BOTTOM)
P032A	M10 SOCKET CAP SCREW	2005	COVER PLATE GASKET (OUTLET)
P034	M10 SPRING WASHER	P004	OUTLET COVER PLATE
P035	HEX CSK PLUG	P032B	M8 SOCKET CAP SCREW
P203	M12 HEX HEAD BOLT	P036	M12 EYEBOLT

IMPORTANT NOTE: -

THE DRAWING REFERENCES SHOWN GIVE THE DESCRIPTION OF ALL THE PARTS DETAILED ON THE SECTIONAL DRAWINGS IN THIS SECTION OF THE BOOK. THEREFORE SOME OF THE REFERENCES MAY NOT BE SHOWN ON ANY ONE.

Torque Tightening Table for Fasteners

DESCRIPTION	THREAD SIZE	PART No.(s)	MAX. TIGHTENING TORQUE	
			Nm	lbf.ft.
SLOTTED HEX NUT	M24 x 3	P028	230	170
HEX HEAD SCREW	M8 x 1.25	P030	29	22
SOCKET CAP SCREW	M8 x 1.25	P031, P032B	29	22
SOCKET CAP SCREW	M10 x 1.5	P032A	56	41
HEX HEAD SCREW	M10 x 1.5	P200	56	41
HEX HEAD BOLT	M12 x 1.75	P202, P203	101	76

Torque tolerances are +/- 5% of stated values.

Muncher Coding

Features	Description	Basic Code												Variation		
		1	2	3	4	5	6	7	8	9	10	11	12	13	14	15
Body Material	Cast Iron	C														
	Stainless Steel **	S														
	Gun Metal **	G														
Product	SB Muncher		B													
Mark No.	1988			2												
Throat Size	100mm (4")				0	1										
Machine Type and Outlet Size	Basic (Channel Type)						A									
	50 N.B. B.S.P.						Z									
	80 N.B. B.S.P.						B									
	100 N.B. B.S.P.						C									
	150 N.B. BS4504 Sect 3.2 PN16						D									
	2" N.B. N.P.T.						F									
	3" N.B. N.P.T.						G									
	4" N.B. N.P.T.						H									
	6" ANSI B16.1 Class 125						J									
Build Option	Refer to NOV							*								
Cutter	CAM								T							
	ETOS								W							
No. of Teeth	5 (ETOS Only)									5						
	7 (CAM Or ETOS)									7						
Thickness	5.5mm (0.2165")										A					
	8.0mm (0.3150")										B					
Material (Cutters)	Stainless Steel (ETOS Only)											1				
	Chromium Molybdenum Steel (CAM Only)											2				
Oblique												/				
Field Variation														V	A	R
Typical Code		C	B	2	0	1	Z	*	W	7	A	2	/	1	2	3

**** These options are not available throughout the range, please consult Mono Pumps for details.**

Note: "X" in any column denotes a special variation.

Dismantling & Assembly Diagrams

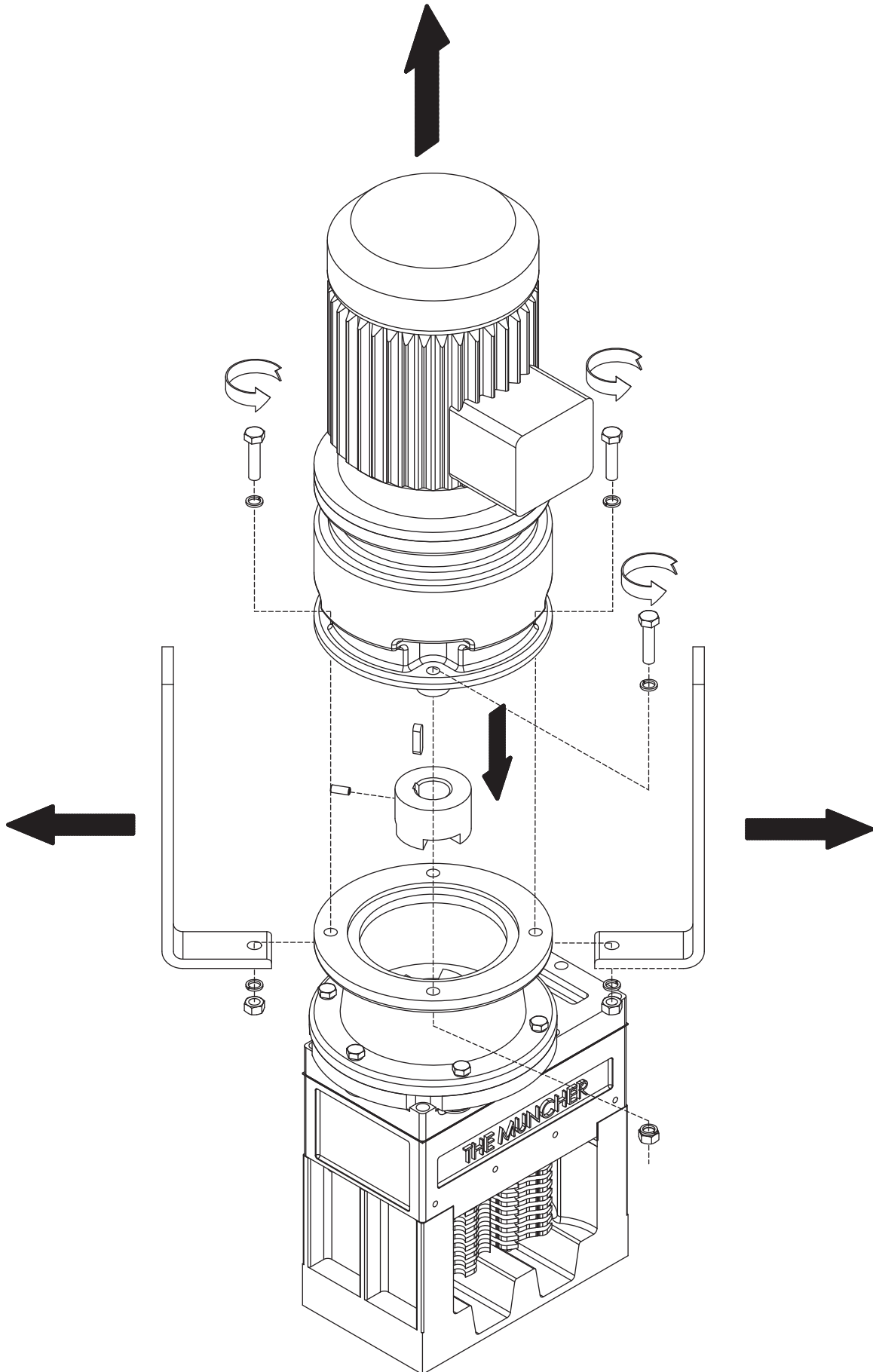

Dismantling & Assembly Diagrams

CHANNEL MODELS ONLY

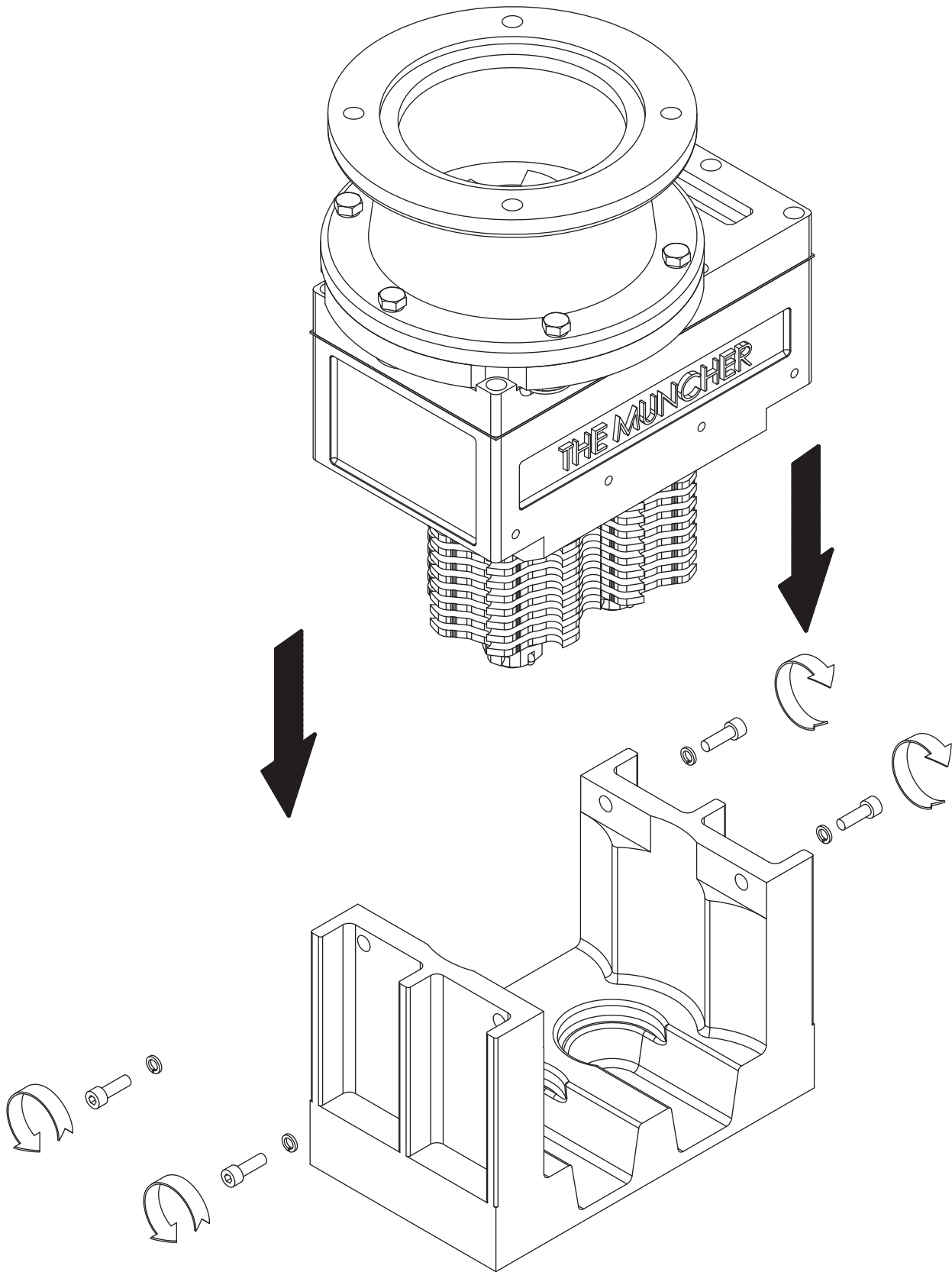

Dismantling & Assembly Diagrams

PIPELINE MODELS ONLY

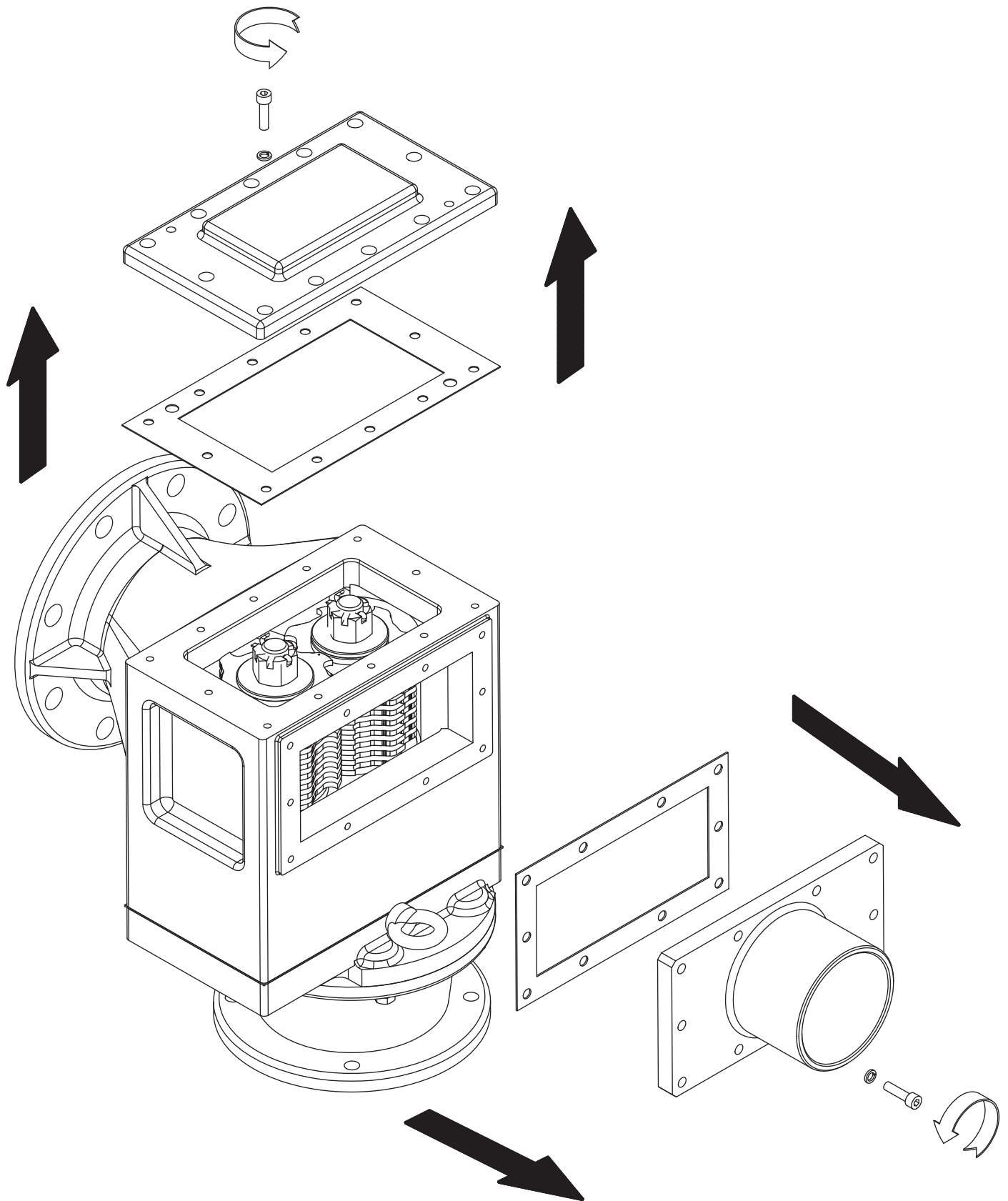

Dismantling & Assembly Diagrams

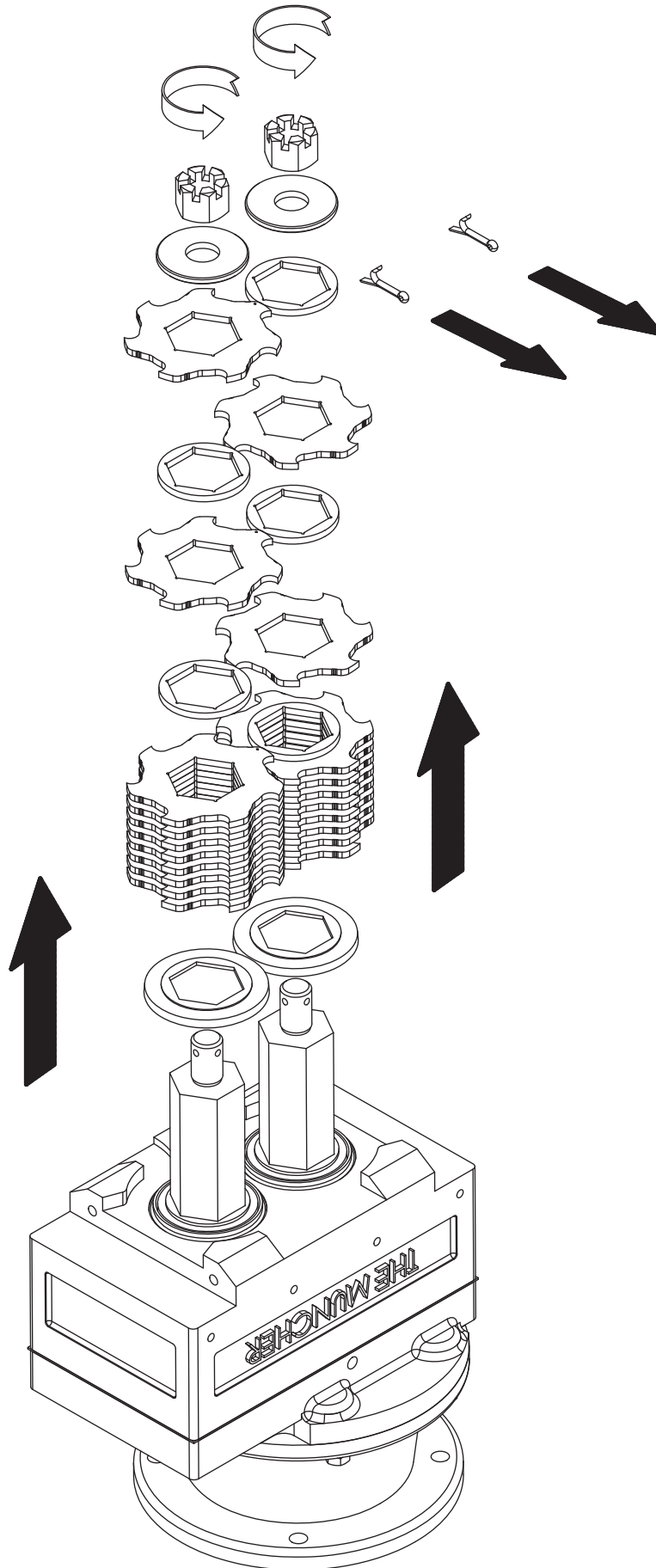

Dismantling & Assembly Diagrams

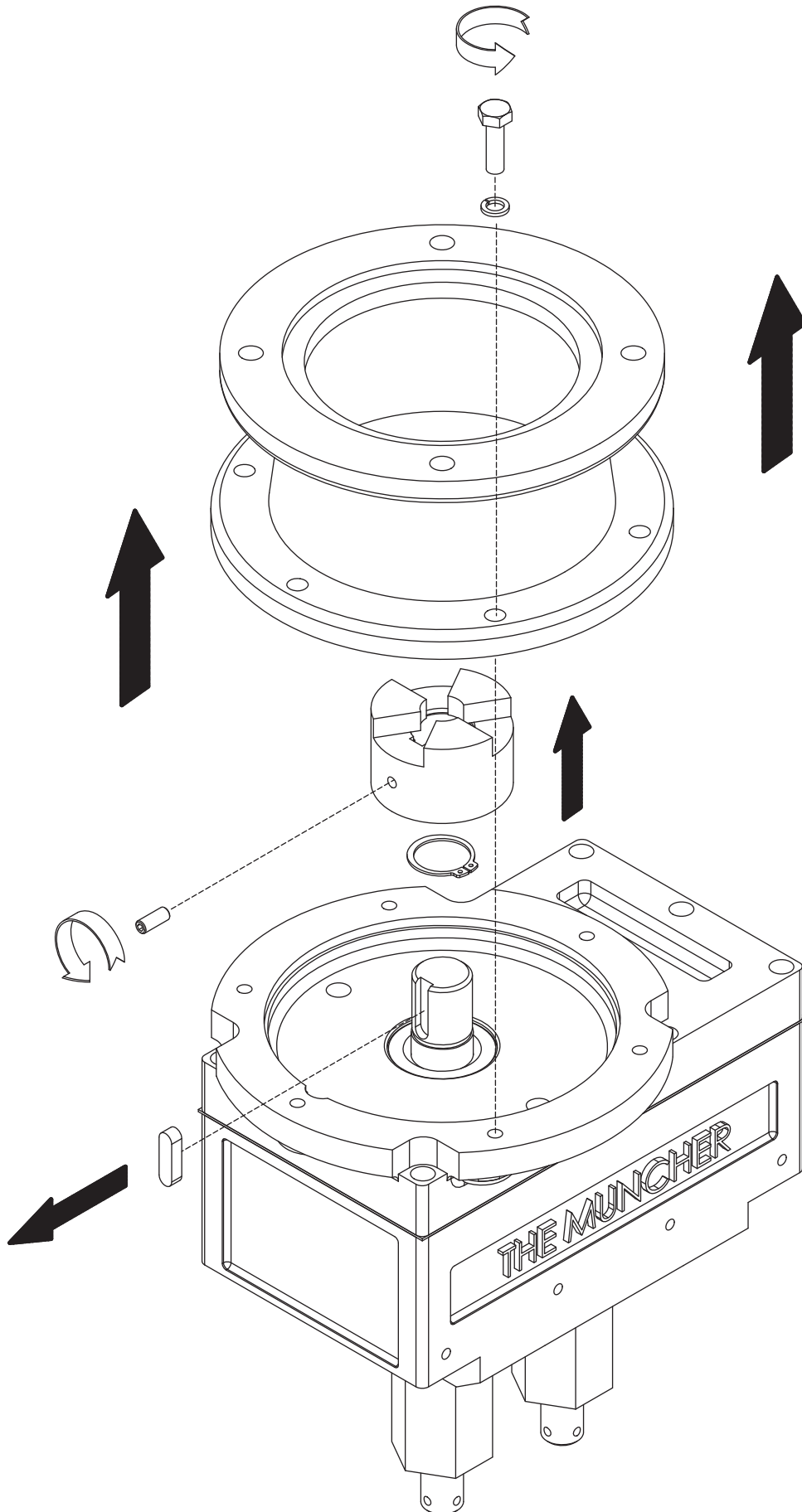

Dismantling & Assembly Diagrams

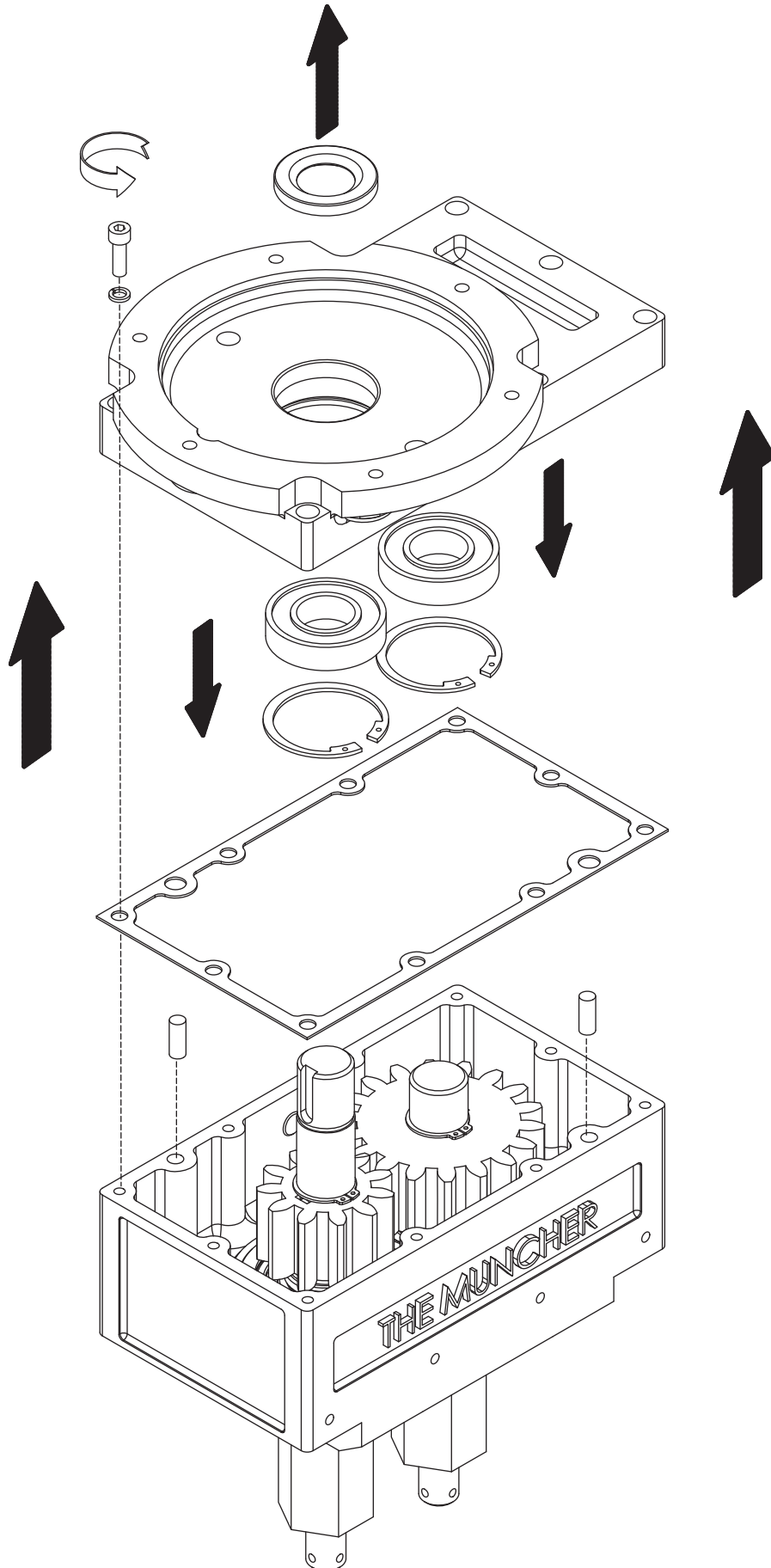

Dismantling & Assembly Diagrams

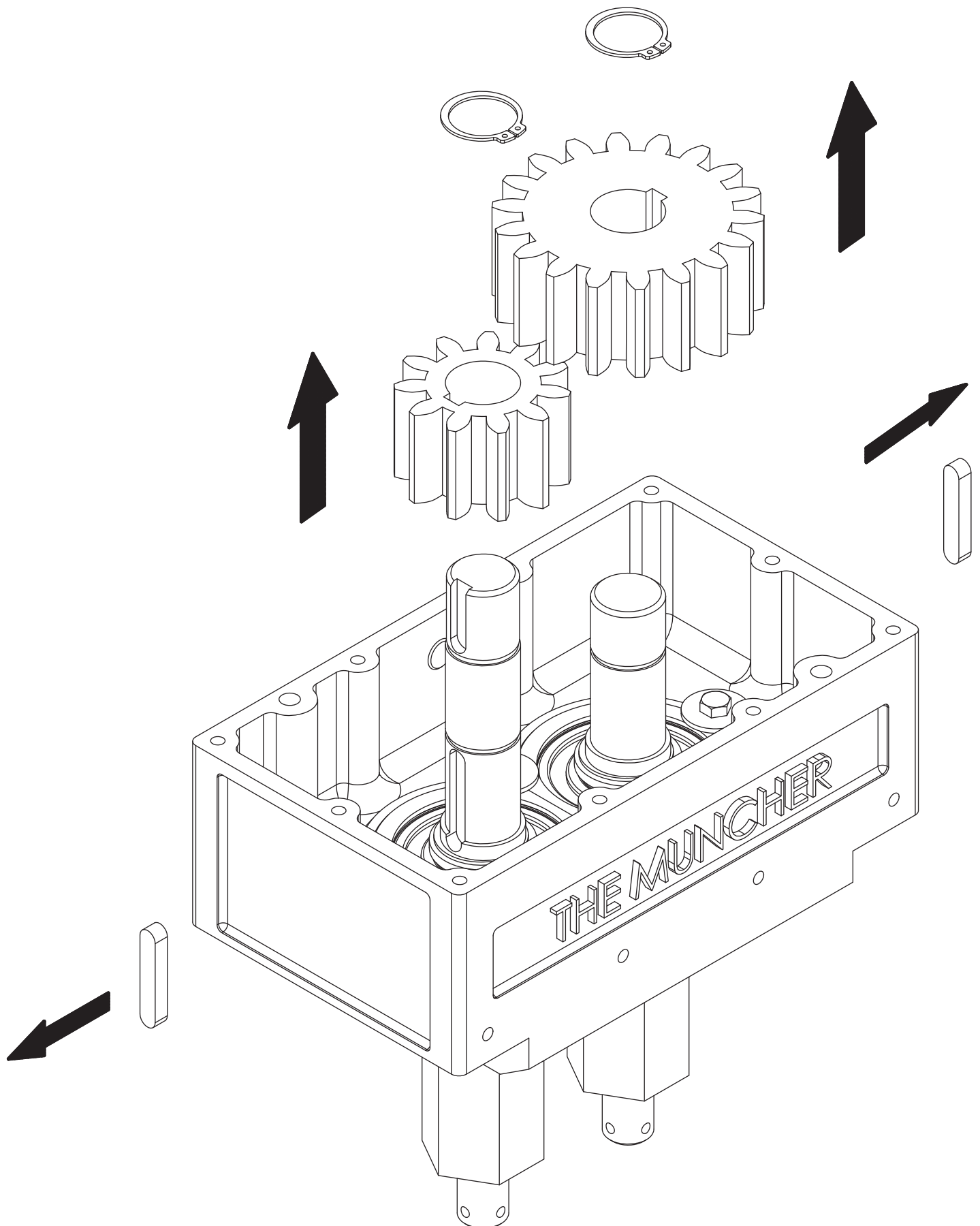

Dismantling & Assembly Diagrams

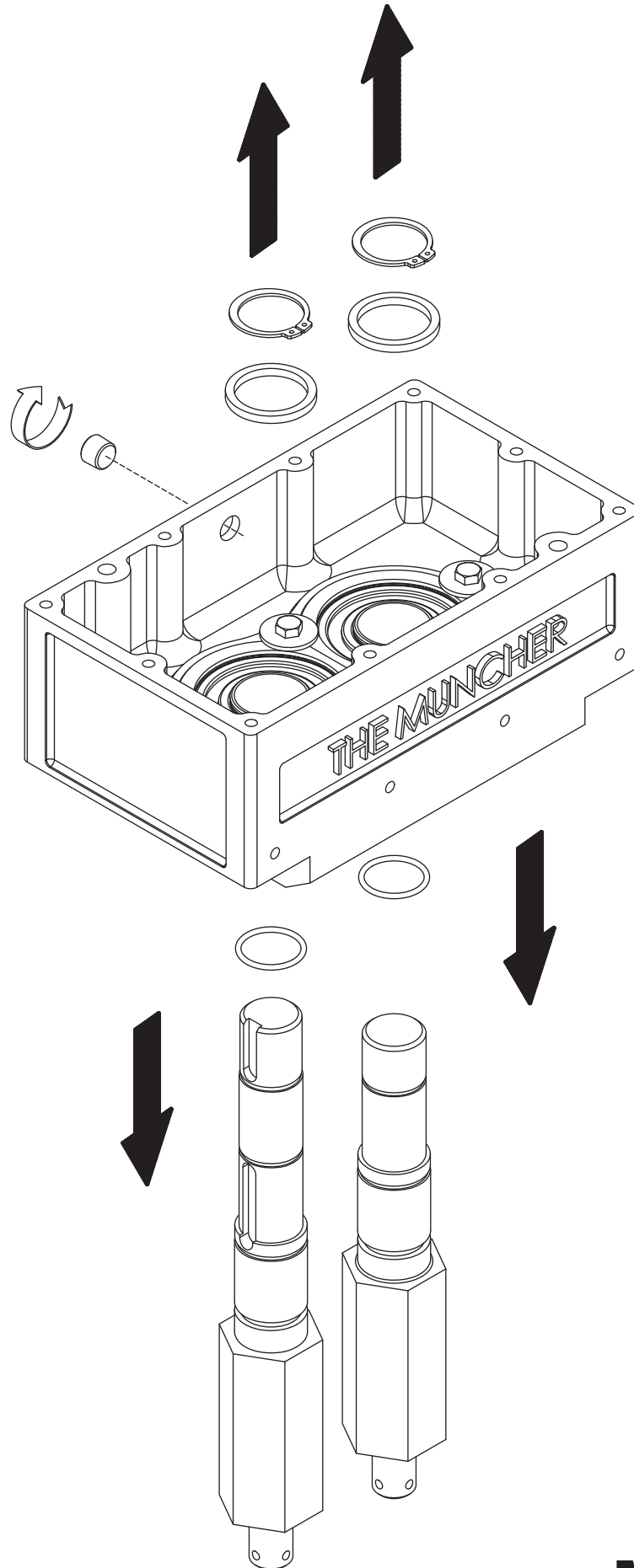

Dismantling & Assembly Diagrams

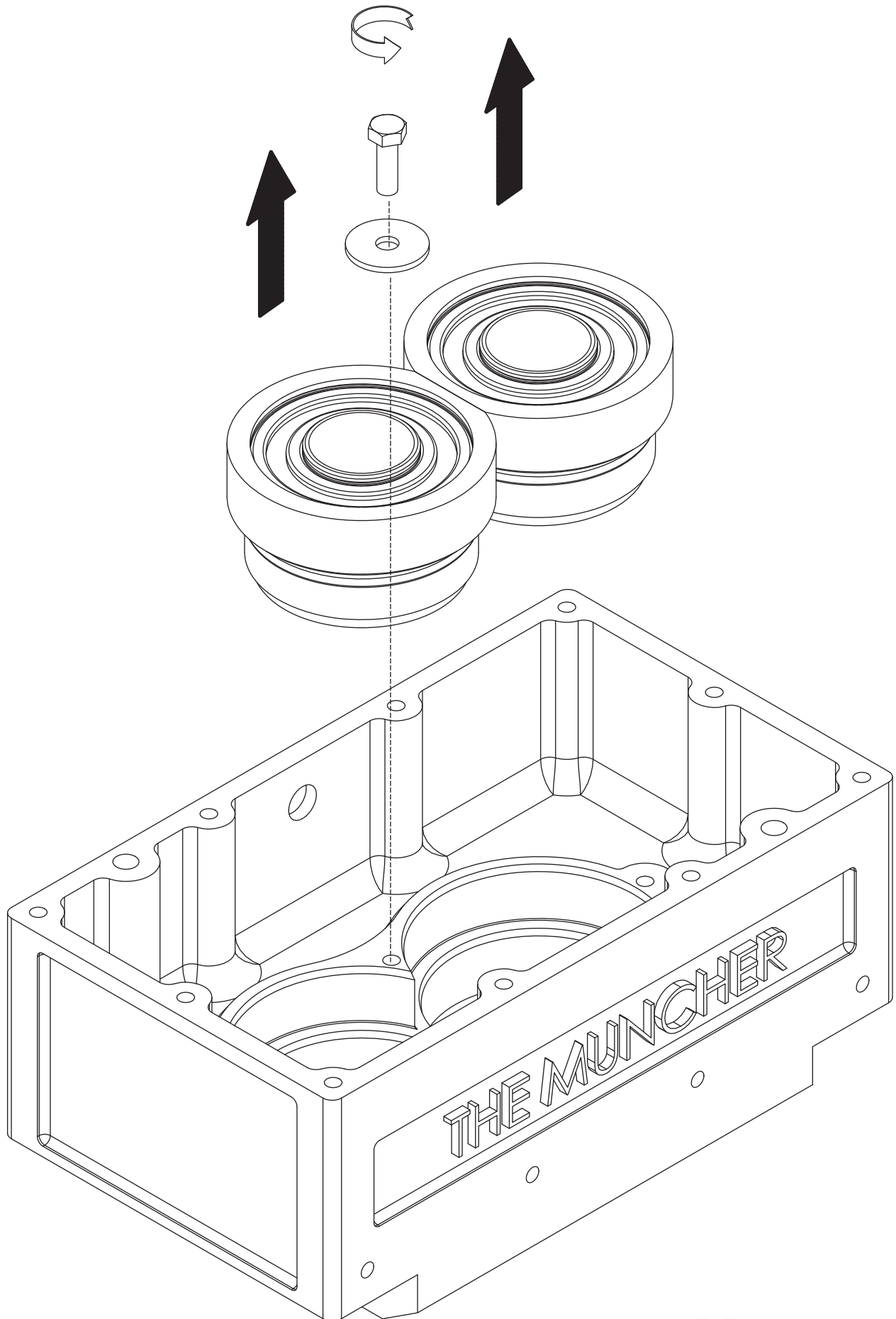

Dismantling & Assembly Diagrams

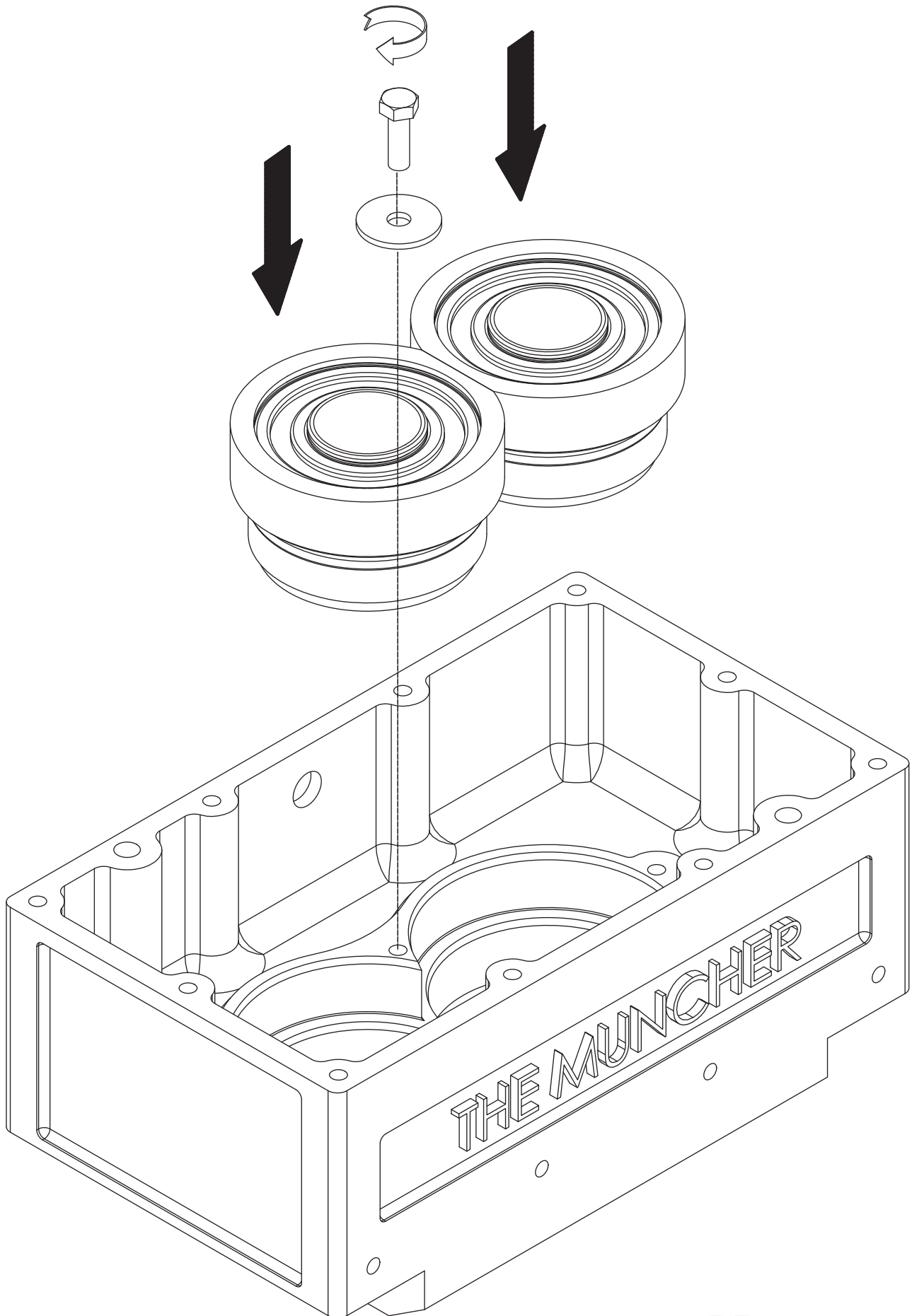

Dismantling & Assembly Diagrams

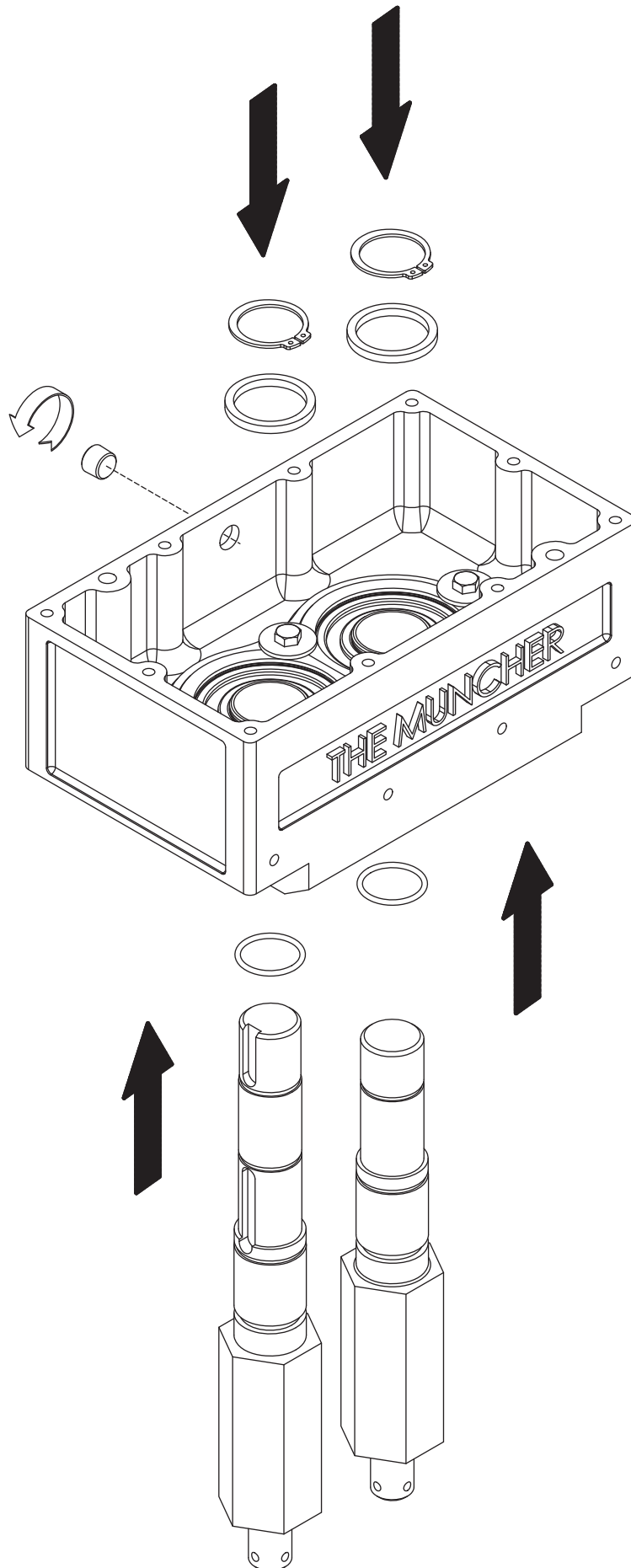

Dismantling & Assembly Diagrams

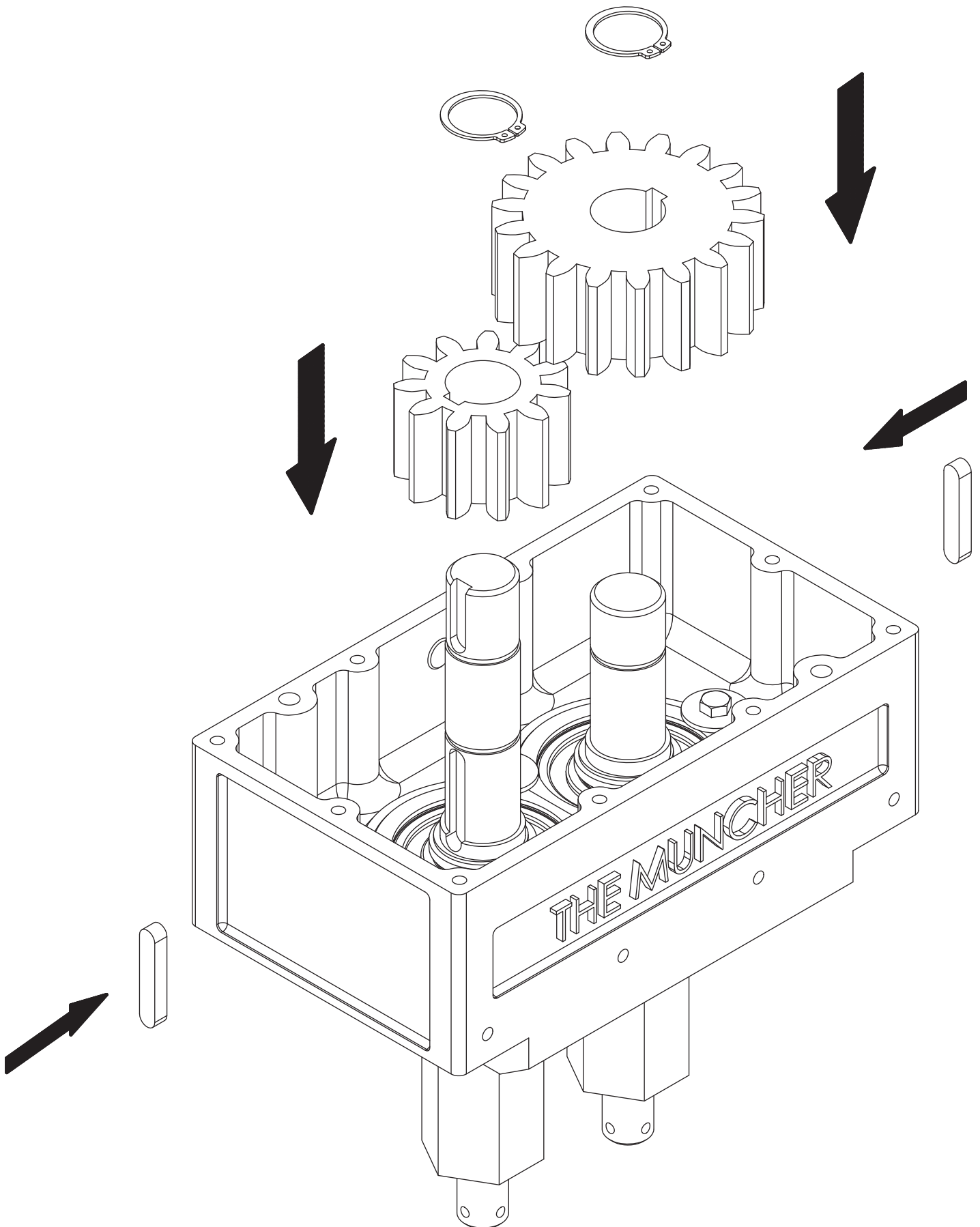

Dismantling & Assembly Diagrams

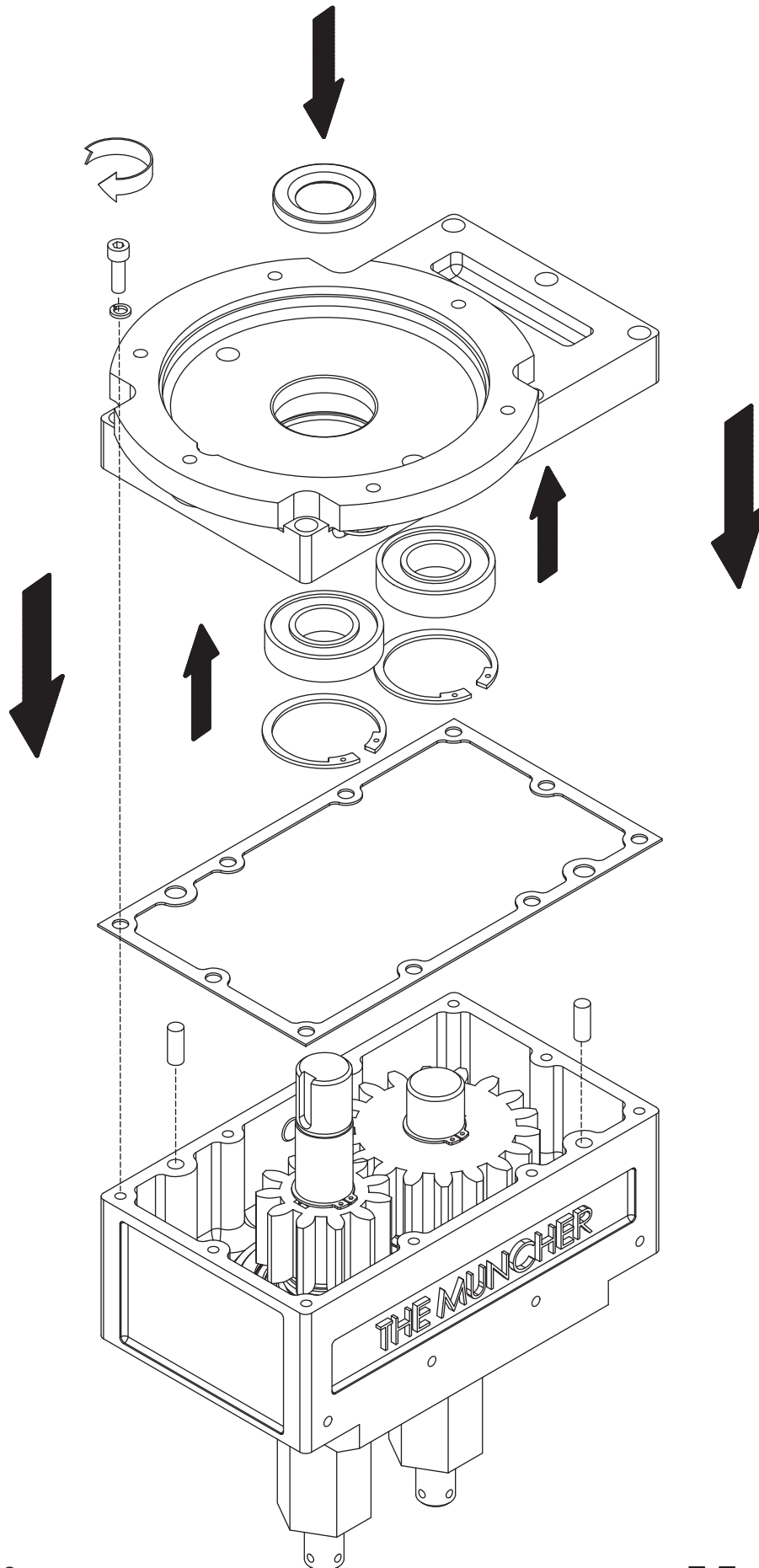

Dismantling & Assembly Diagrams

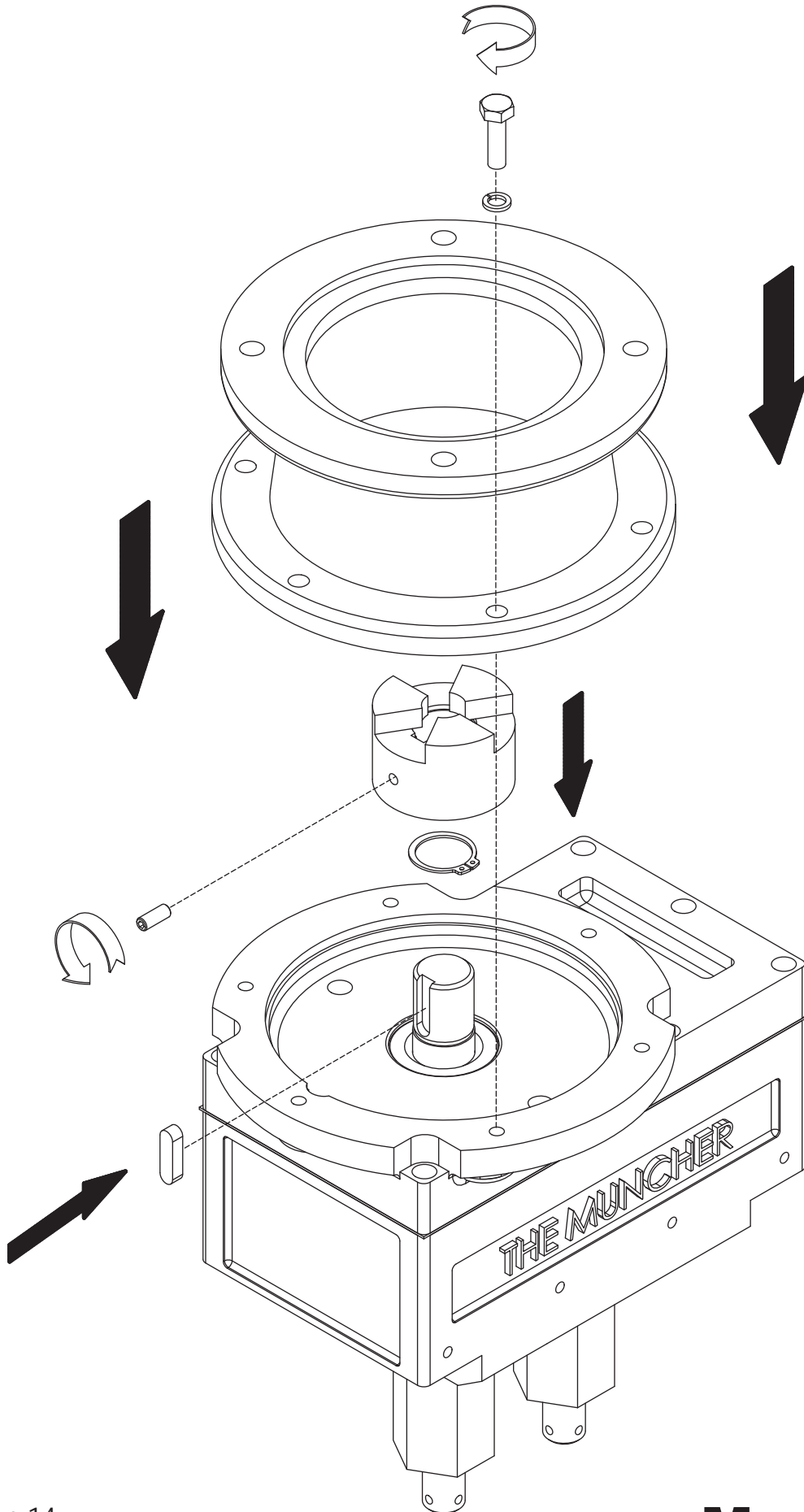

Dismantling & Assembly Diagrams

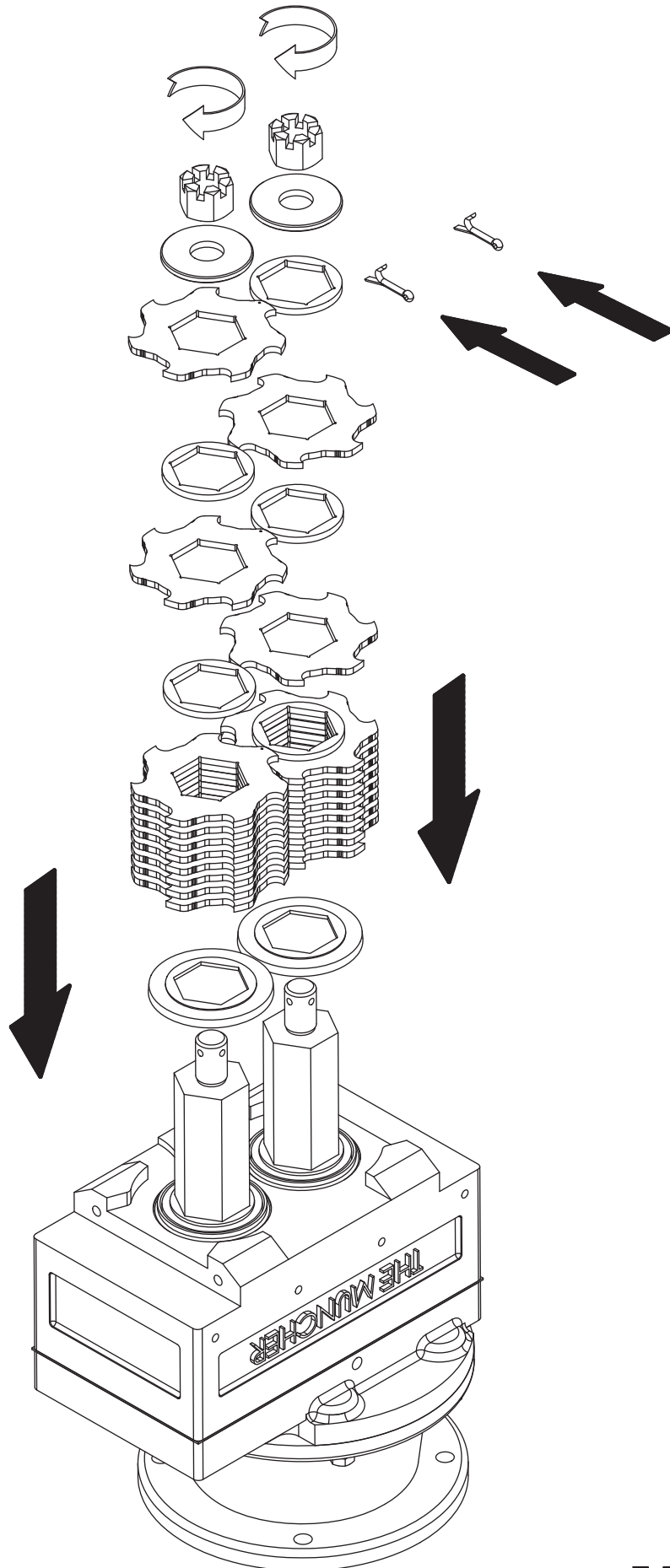

Dismantling & Assembly Diagrams

PIPELINE MODELS ONLY

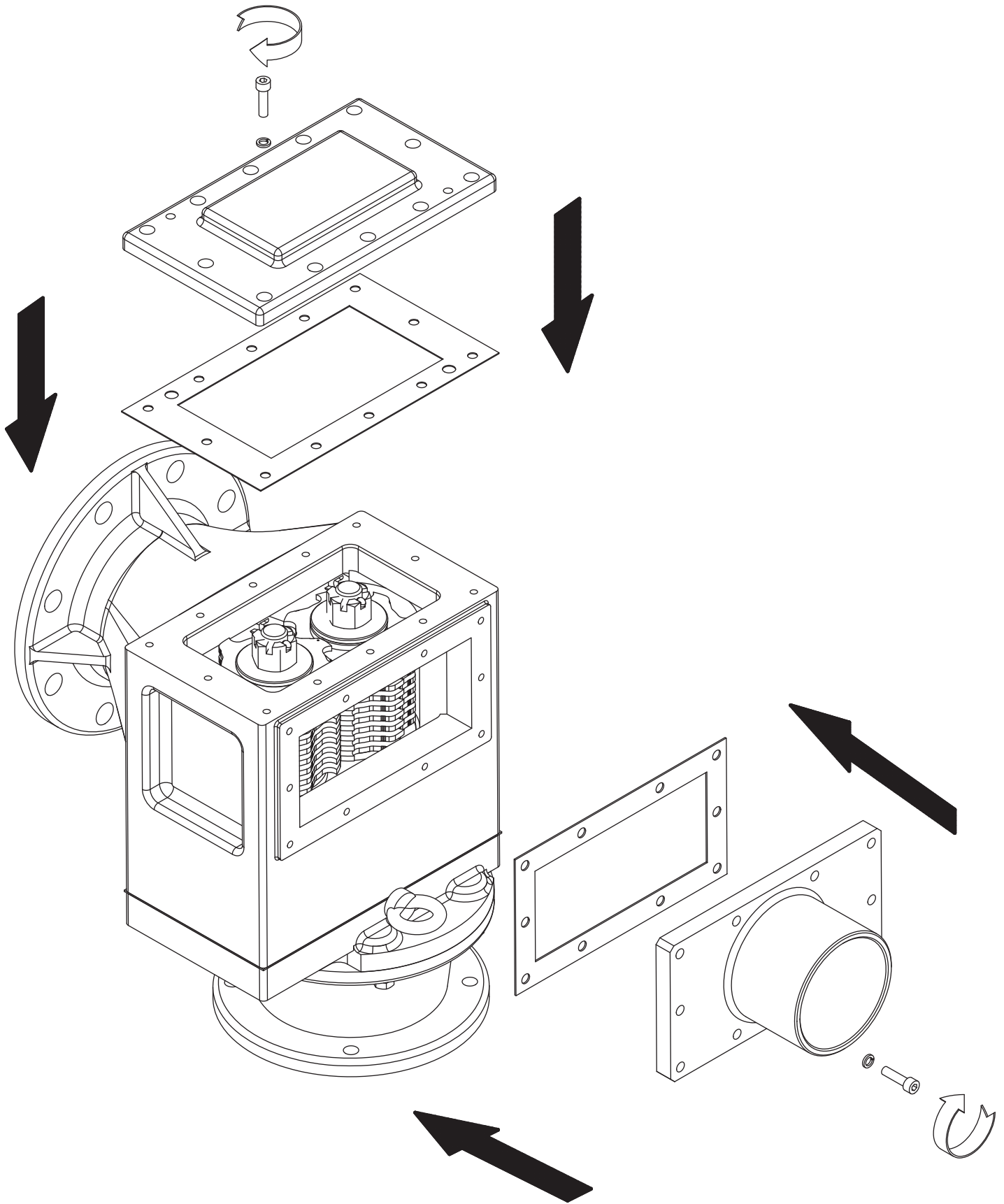

Dismantling & Assembly Diagrams

CHANNEL MODELS ONLY

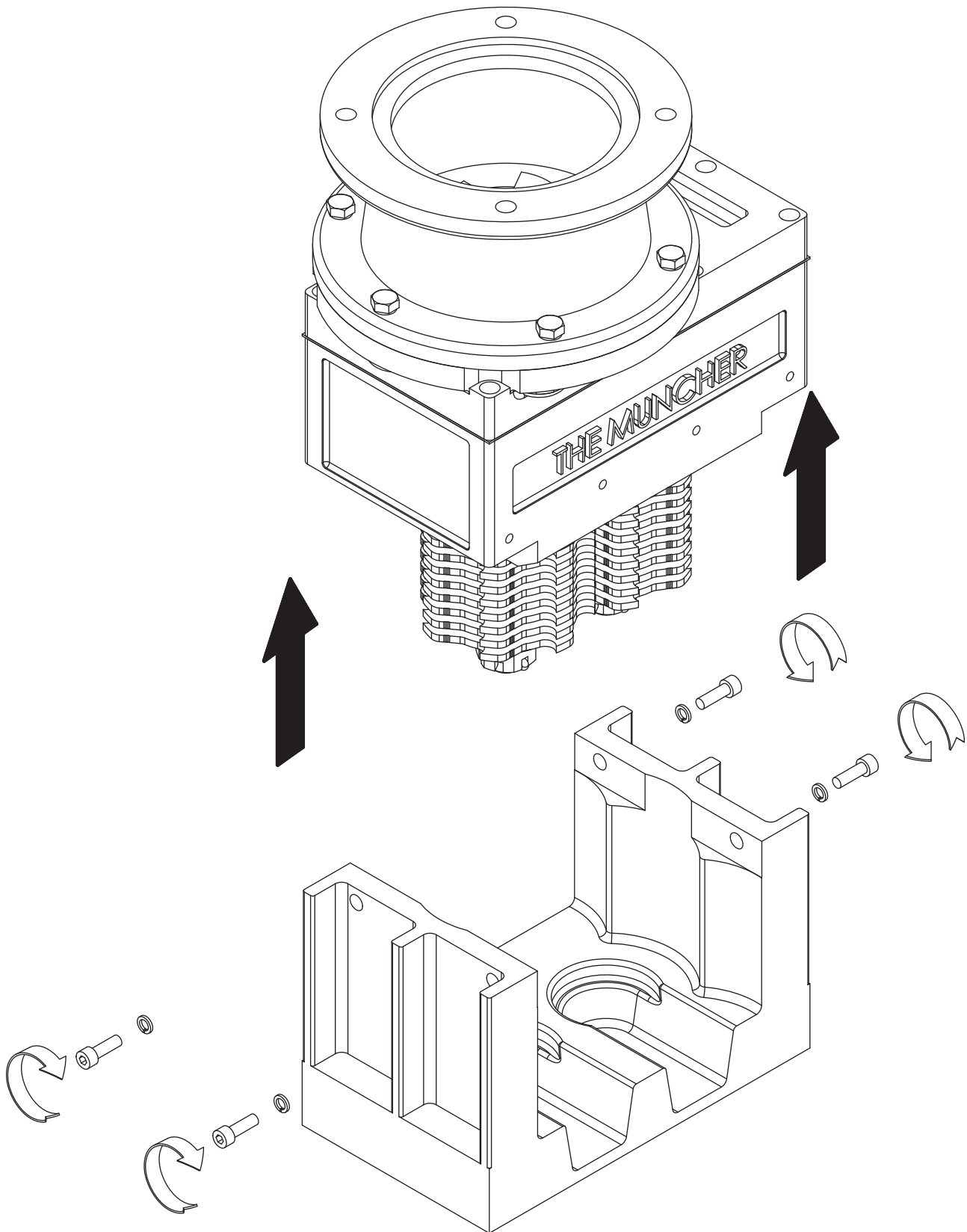

Dismantling & Assembly Diagrams

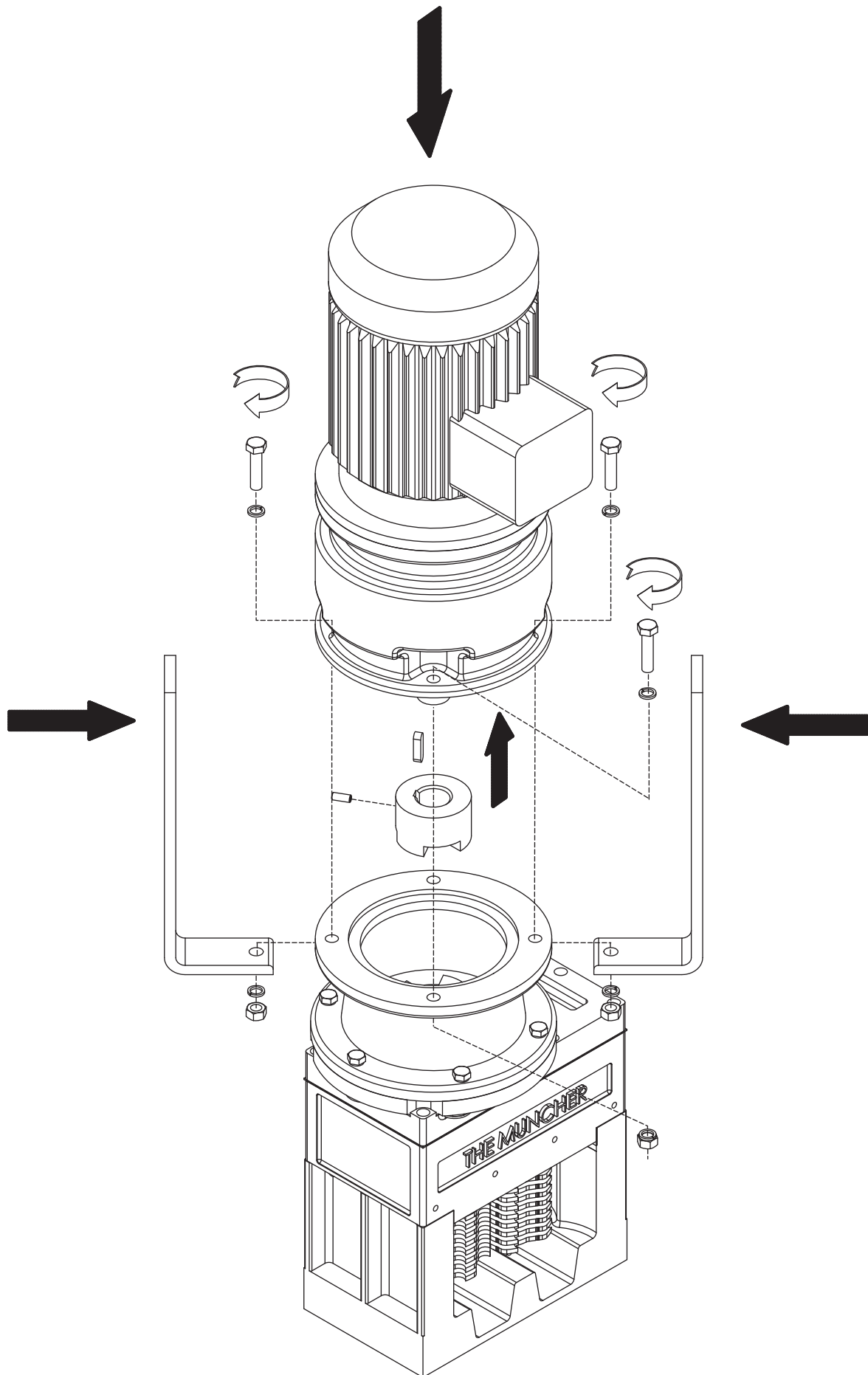

Exploded Views

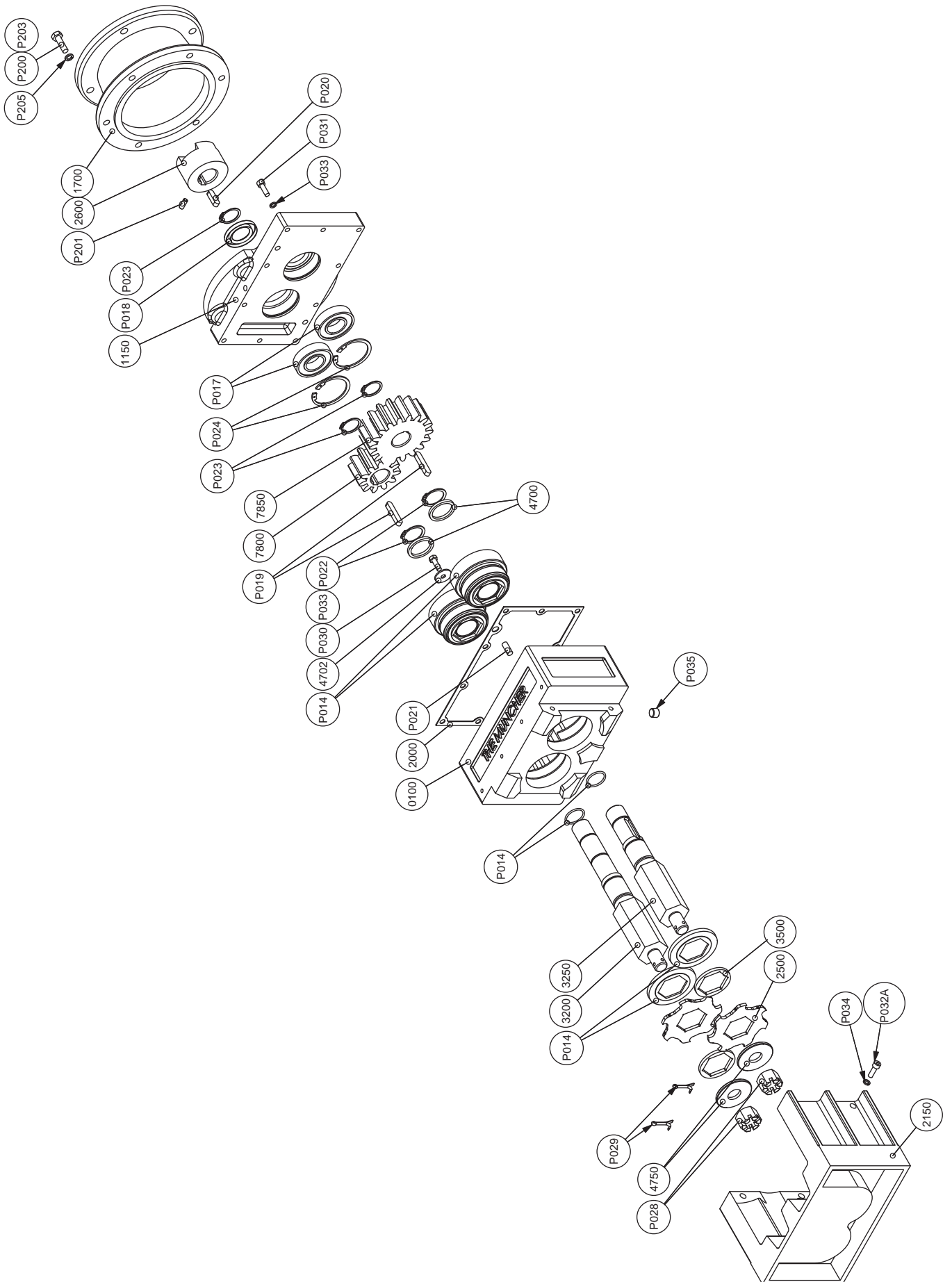

Exploded Views

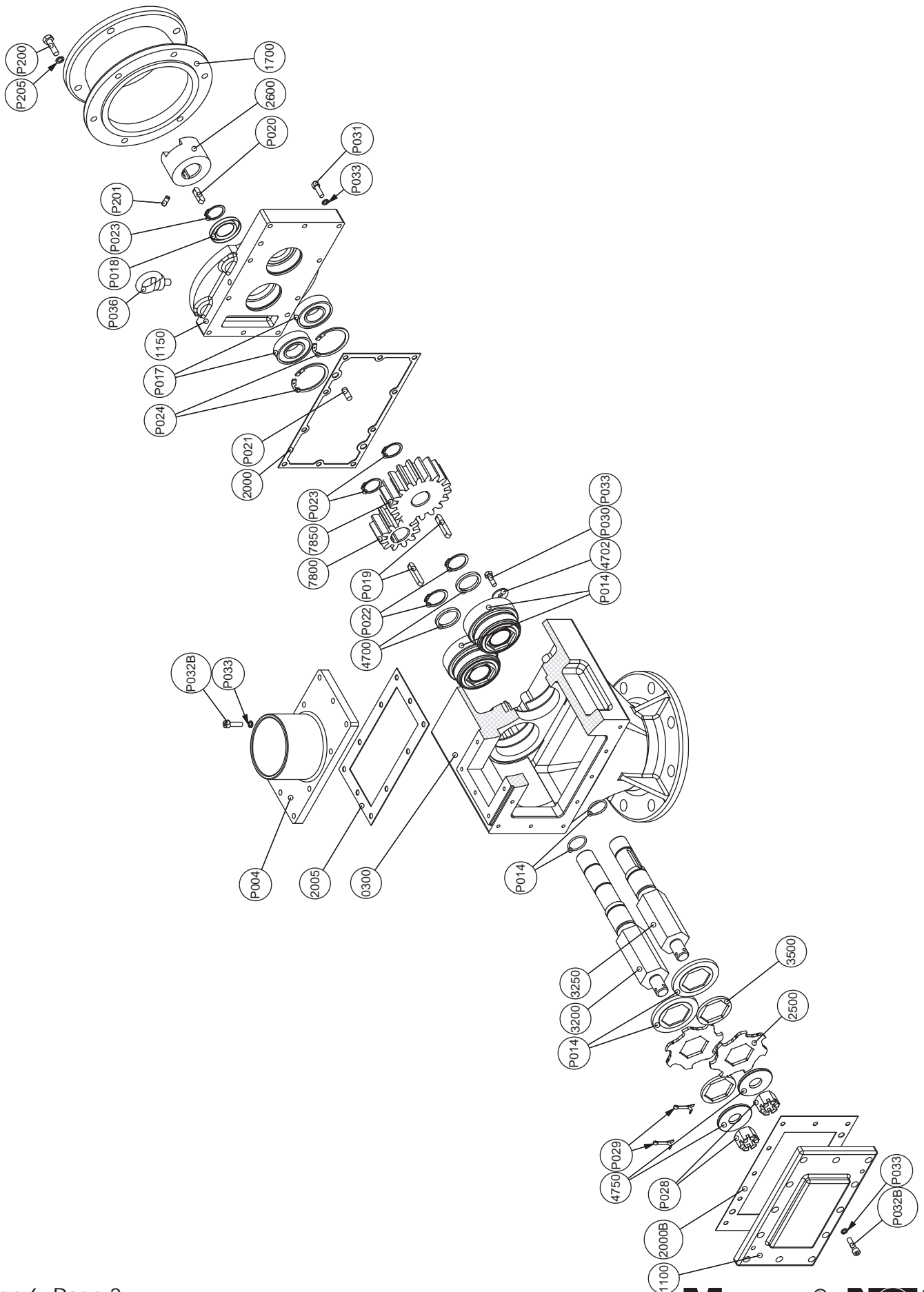

Sectional Arrangement

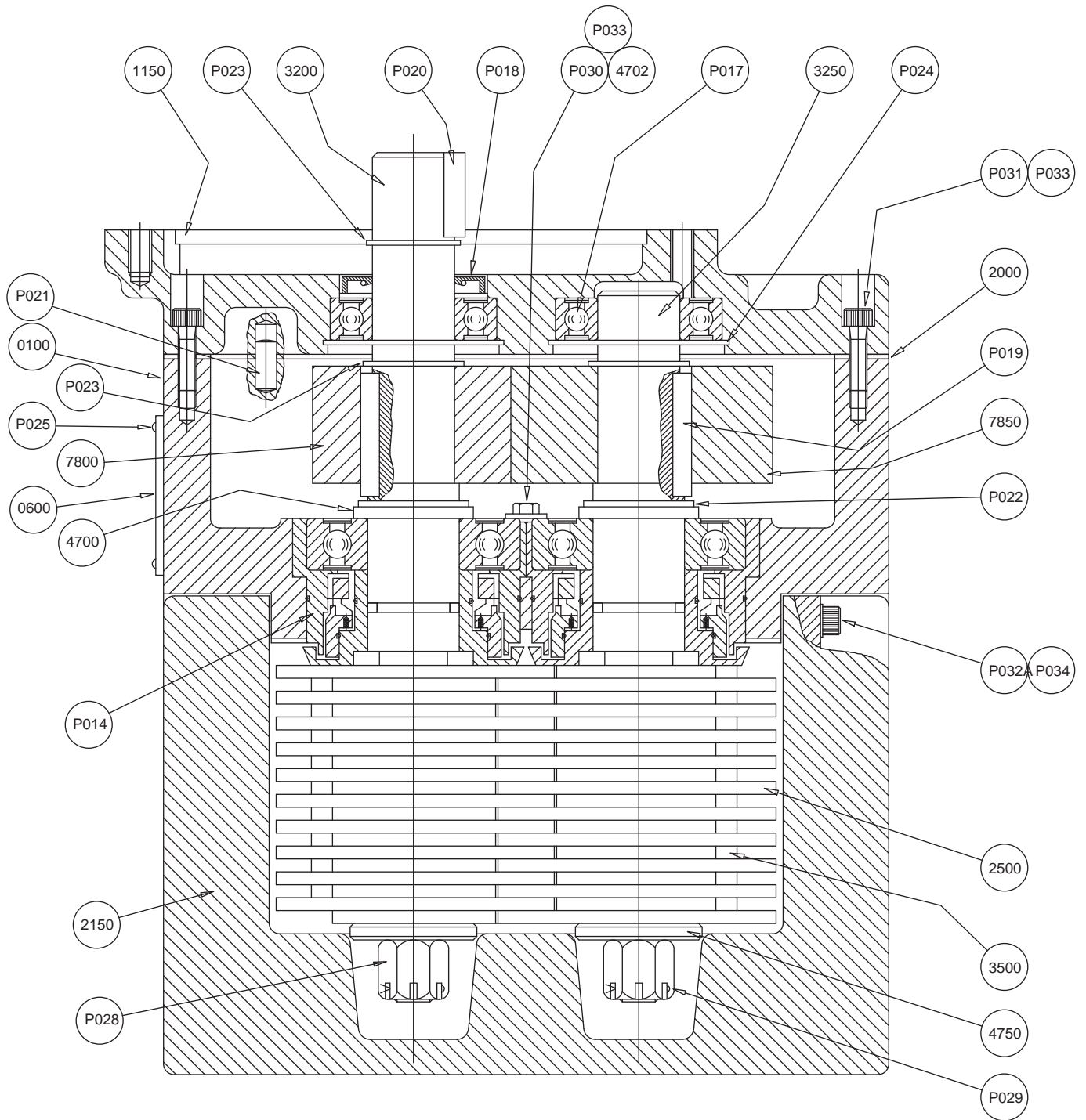

Drawing Number B01A 9805

Sectional Arrangement

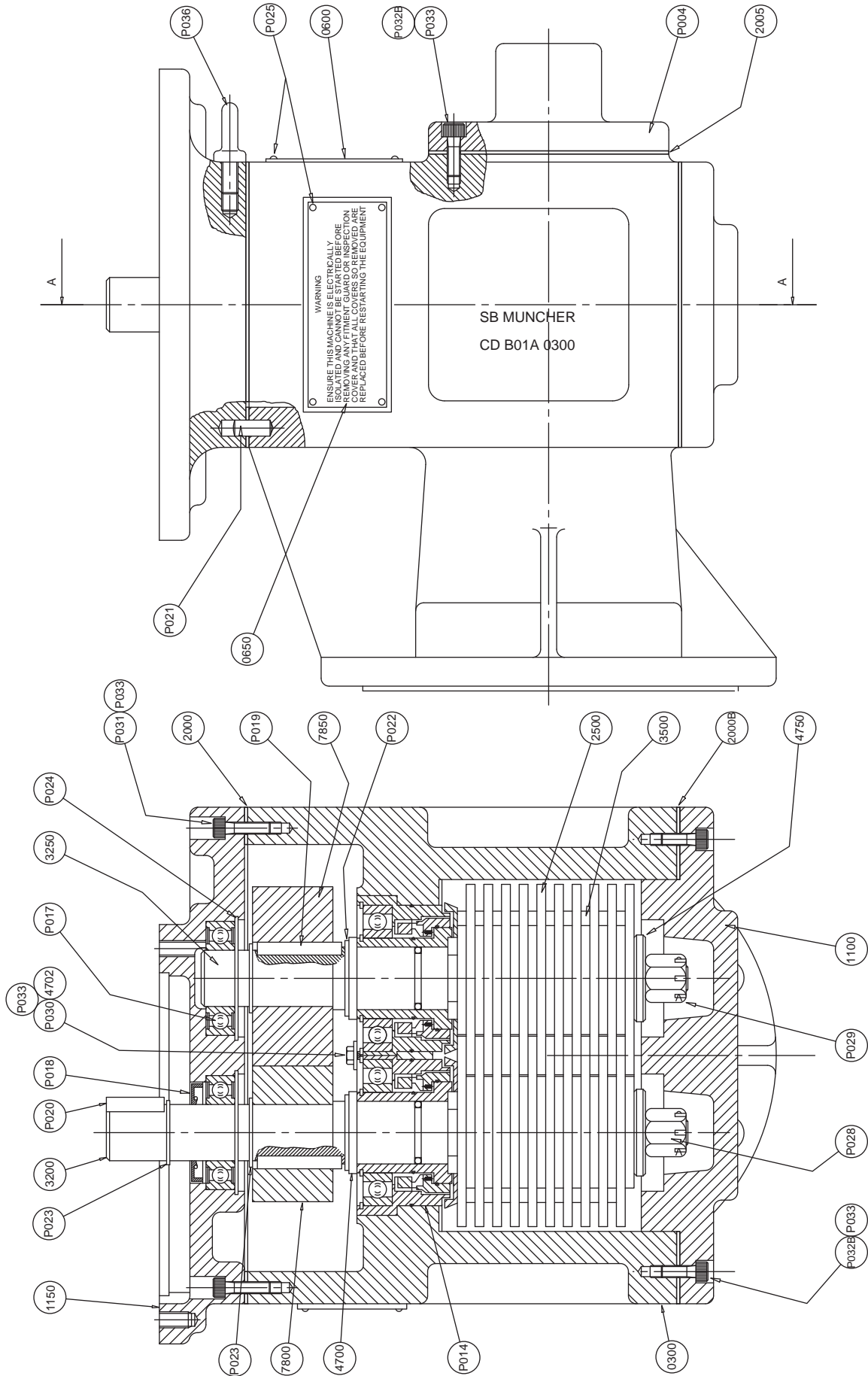

Drawing Number B01A 9800

General Arrangement

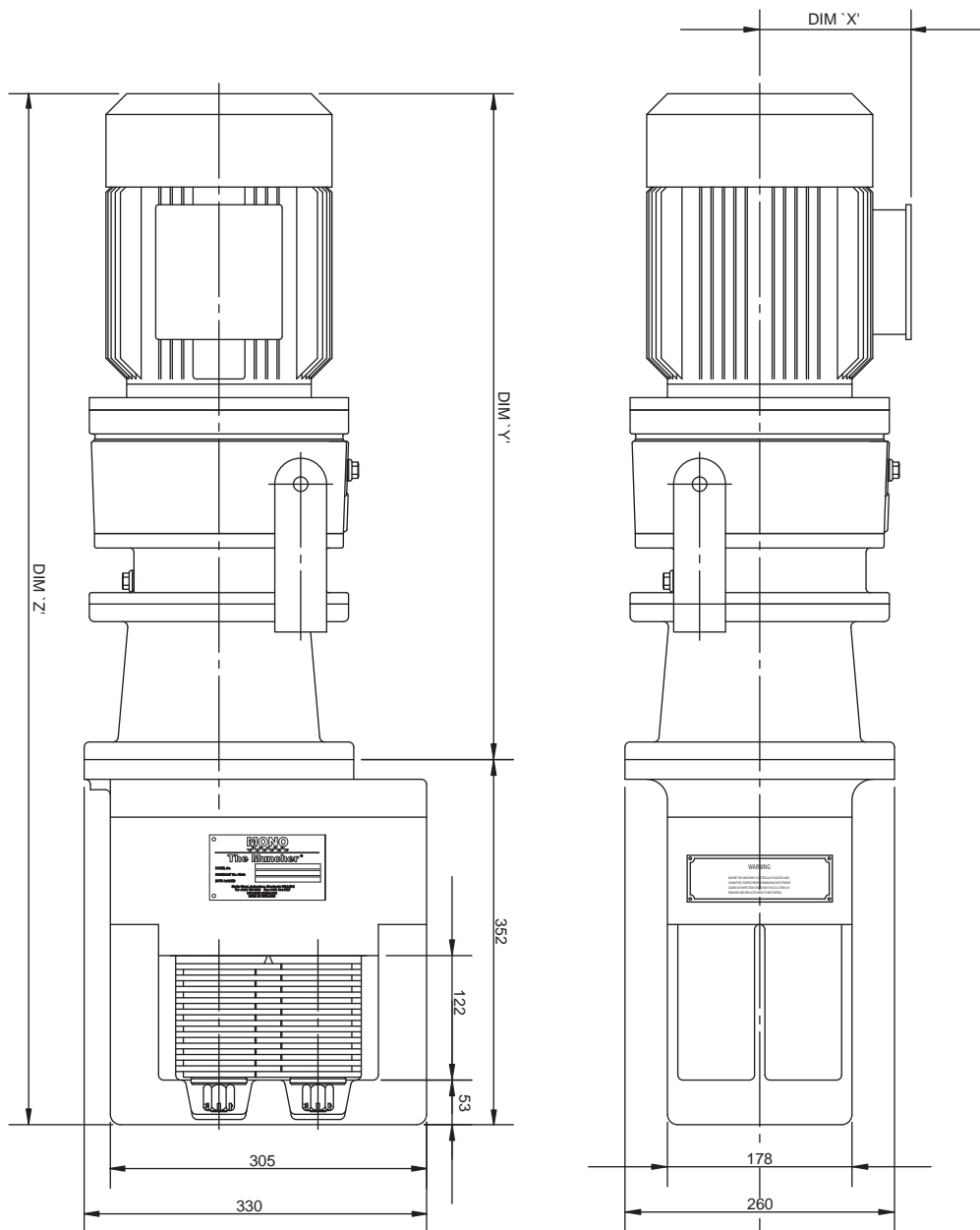

MOTOR		DIM 'X'	DIM 'Y'	DIM 'Z'	WEIGHT
KW	IP	(MAX)	(MAX)	(MAX)	(MAX)
1.1	55	135	657	1009	155Kg
	67&68	241	679	1031	200Kg
1.5	55	140	717	1069	190Kg
	67&68	241	717	1069	225Kg
2.2	55	154	739	1091	195Kg
	67&68	289	746	1098	260Kg

Drawing Number B01A 9901

General Arrangement

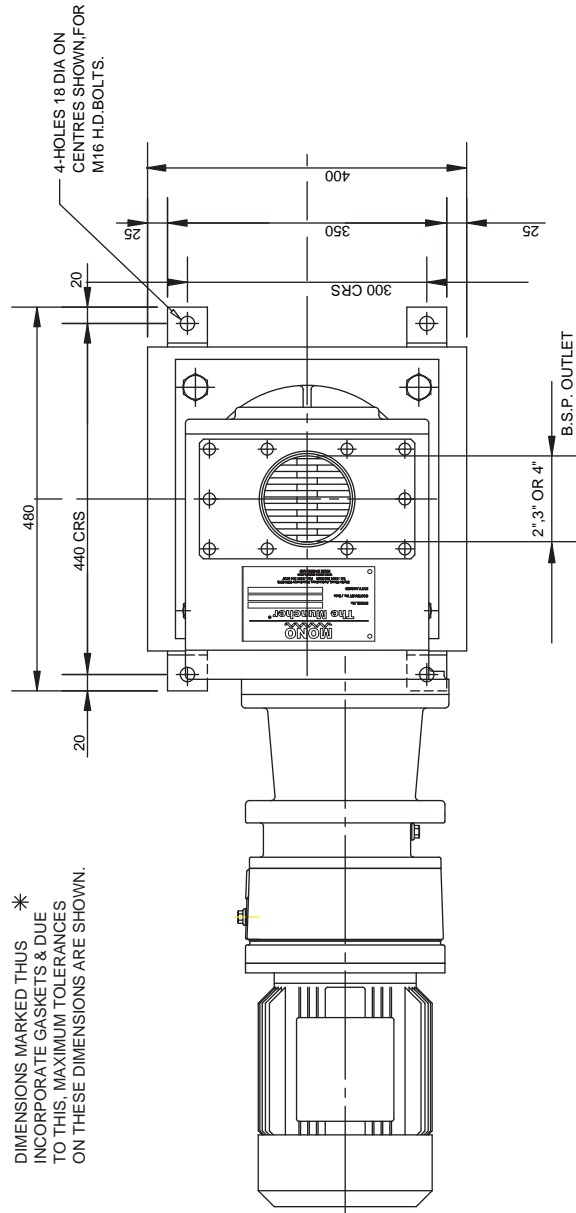
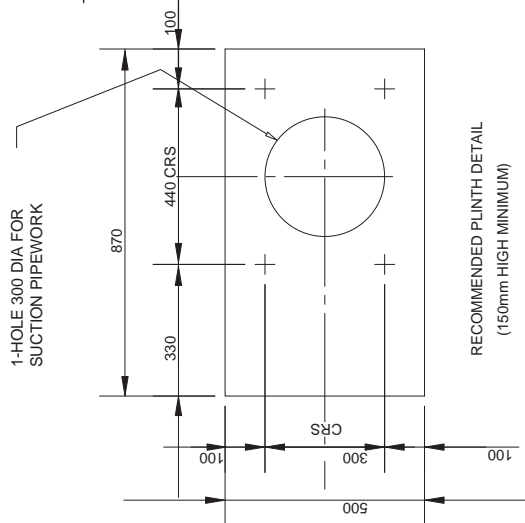
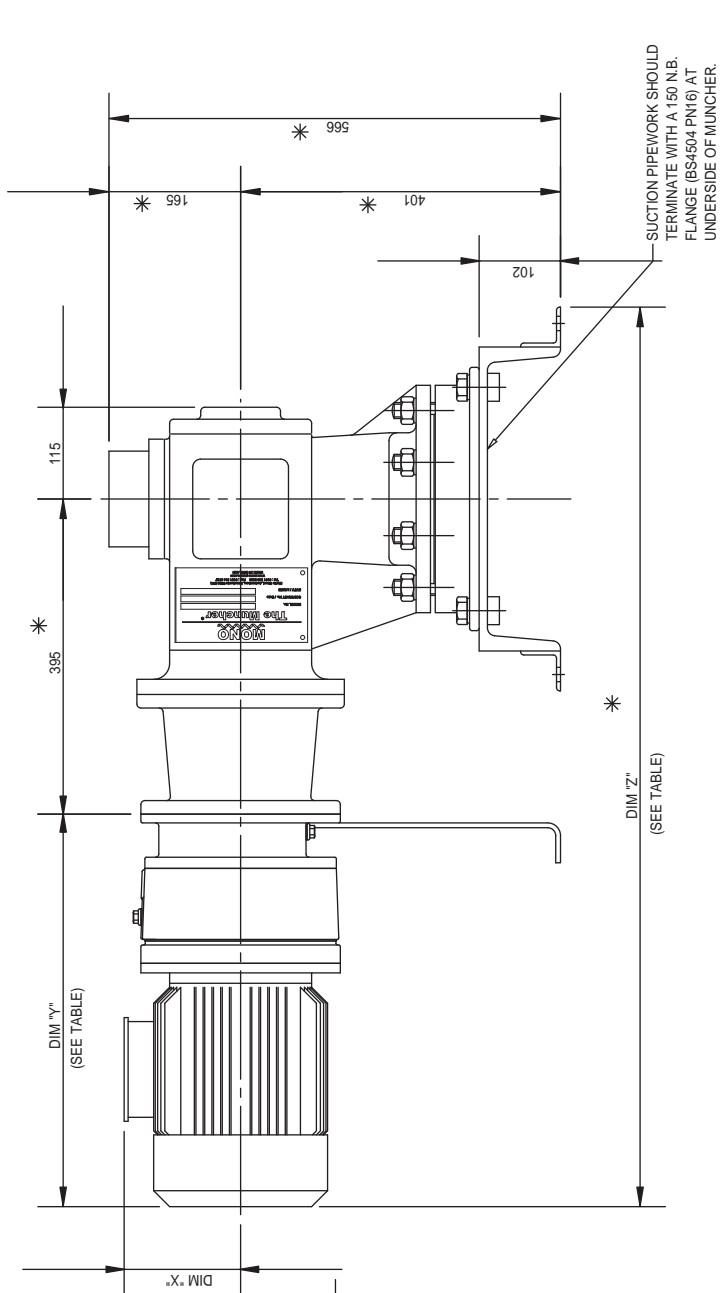

DIMENSIONS MARKED THUS * INCORPORATE GASKETS & DUJ TO THIS, MAXIMUM TOLERANCES ON THESE DIMENSIONS ARE SHOWN.

FOR RENOLD GEAR/UNITS			
MOTOR	DIM "X"	DIM "Y"	DIM "Z"
1.1KW	132	411	1046
1.5KW	132	411	1046
2.2KW	146	477	1112

FOR RAYNER GEAR/UNITS			
MOTOR	DIM "X"	DIM "Y"	DIM "Z"
1.1KW	135	507	1142
1.5KW	140	567	1202
2.2KW	154	589	1224

Drawing Number B01A 9906

Lifting Diagrams

CHANNEL MODELS

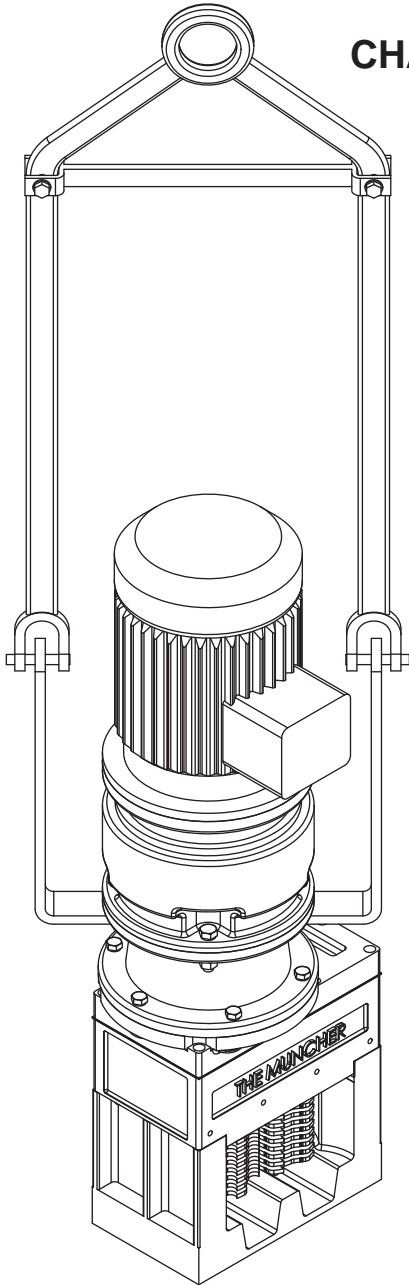

PIPELINE MODELS

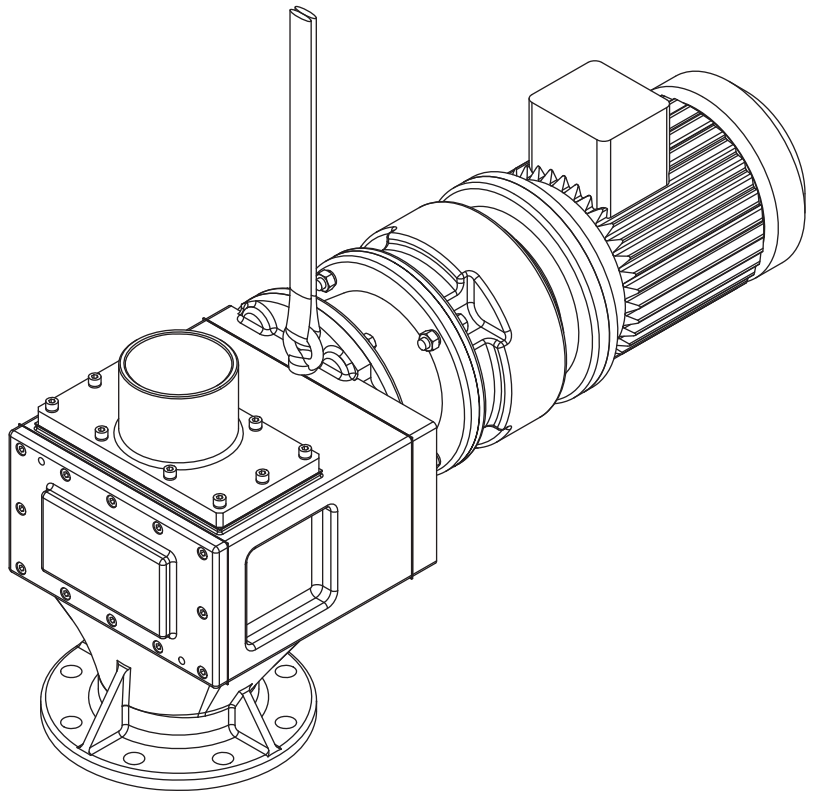



Member of AxFlow Group

1300 4 BBENG
www.brownbros.com.au



Member of AxFlow Group

0508 4 BBENG
www.brownbros.co.nz

Mono[®] NOV

One Company, Unlimited Solutions