



English

Original Instructions

# Installation, Operation and Maintenance Instructions

## Epsilon Range

E14A - E1BK

single stage, two stage & K build

# Spares & Service Contact Details

## Mono UK

<b>Spares</b>	+44 (0)161 214 2380 (direct line 8.15 am – 5.00 pm)
<b>E-mail</b>	spares@mono-pumps.com
<b>Service</b>	+44 (0)161 214 2390 (direct line 8.15 am – 5.00 pm)
<b>E-mail</b>	customerservices@mono-pumps.com
<b>Service</b>	+44 (0)161 339 9000 (24 hrs)

## Mono Australia

	<b>Telephone</b>	<b>Facsimile</b>
<b>Melbourne</b>	(03) 9580 5211	(03) 9580 9036
<b>Sydney</b>	(02) 9521 5611	(02) 9542 3649
<b>Brisbane</b>	(07) 3350 4582	(07) 3350 3750
<b>Adelaide</b>	(08) 8447 8333	(08) 8447 8373
<b>Perth</b>	(08) 9479 0444	(08) 9479 0400
<b>Darwin</b>	(08) 8984 3099	(08) 8947 0540
<b>Tasmania</b>	0417 345 814	(03) 6330 2051
<b>E-mail</b>	ozsales@mono-pumps.com	

## Mono New Zealand

<b>Spares &amp; Service</b>	+64 (0)9 829 0333
<b>E-mail</b>	info@mono-pumps.co.nz

## Monoflo USA

<b>Spares &amp; Service</b>	+1 713 466 7999
<b>E-mail</b>	inquire@monoflo.com

## Monoflo South America

<b>Spares &amp; Service</b>	+54 4296 8997	+54 4284 0323
<b>E-mail</b>	inquire@monoflo.com	

## Mono China

	<b>Telephone</b>	<b>Facsimile</b>
<b>Beijing</b>	+86 (0) 10 6461 1115	+86 (0) 10 8486 8481
<b>Shanghai</b>	+86 (0) 21 5915 7168	+86 (0) 21 5915 6863
<b>E-mail</b>	monoshanghai@nov.com	

# ATEX Warning Statements

## PUMPS AND PUMP UNITS

Where a pump or pump unit is to be installed in a potentially explosive atmosphere ensure that this has been specified at the time of purchase and that the equipment has been supplied accordingly and displays an ATEX nameplate or is supplied with a certificate of conformity. If there is any doubt as to the suitability of the equipment please contact Mono Pumps Limited before commencing with installation and commissioning.

Process liquids or fluids should be kept within specified temperature limits otherwise the surface of pump or system components may become an ignition source due to temperature rises. Where the process liquid temperature is less than 90°C the maximum surface temperature will not exceed 90°C provided the pump is installed, operated and maintained in accordance with this manual. Where the process fluid temperature exceeds 90°C the maximum surface temperature will be equal to the maximum process fluid temperature.

Cavities that could allow the accumulation of explosive gases, such as under guards, should where possible, be designed out of the system. Where this is not possible they should be fully purged before any work is carried out on the pump or system.

Electrical installation and maintenance work should only be carried out by suitably qualified and competent persons and must be in accordance with relevant electrical regulations.

All electrical equipment, including control and safety devices, should be suitably rated for the environment in to which they are installed.

Where there may be a risk of an accumulation of explosive gases or dust non-sparking tools should be used for installation and maintenance.

In addition to causing permanent damage to the stator, dry running of the pump could generate a rapid rise in the temperature of the stator tube or barrel, which could become an ignition source. It is therefore essential that a dry run protection device be fitted. This must shut the pump down immediately should a dry run situation occur. Details of suitable devices are available from Mono Pumps Limited.

To minimise the risk of sparking or temperature rises due to mechanical or electrical overload the following control and safety devices should be fitted in addition to a dry run protection system. A pressure relief system whereby the pump can not generate pressures in excess of the maximum rated pressure or an over pressure device which should shut the pump down when the maximum discharge pressure is exceeded. A control system that will shut the pump down if the motor current or temperature exceed specified limits. An isolator switch that will disconnect all electrical supply to the motor and ancillary electrical equipment and be capable of being locked in the off position. All control and safety devices should be fitted, operated and maintained in accordance with the manufacturer's instructions. All valves on the system should be open when the pump is started otherwise serious mechanical overload and failure may result.

It is important that the pump rotates in the direction indicated on the nameplate. This must be checked on installation and commissioning and after any maintenance has been carried out. Failure to observe this may lead to dry running or mechanical or electrical overload.

# ATEX Warning Statements

When fitting drives, couplings, belts, pulleys and guards to a pump or pump unit it is essential that these are correctly fitted, aligned and adjusted in accordance with the manufacturer's instructions. Failure to do so may result in sparking due to unintended mechanical contact or temperature rises due to mechanical or electrical overload or slipping of drive belts. Regular inspection of these parts must be carried out to ensure they are in good condition and replacement of any suspect part must be carried out immediately.

Mechanical seals should be suitably rated for the environment. The seal and any associated equipment, such as a flushing system, must be installed, operated and maintained in accordance with the manufacturer's instructions.

Where a packed gland seal is fitted this must be correctly fitted and adjusted. This type of seal relies on the process liquid to cool the shaft and packing rings so a constant drip of liquid from the gland section is required. Where this is undesirable an alternative seal type should be fitted.

Failure to operate or maintain the pump and ancillary equipment in line with the manufacturer's instructions may lead to premature and potentially dangerous failure of components. Regular inspection, and where necessary replacement, of bearings and lubrication is essential.

The pump and its components have been designed to ensure safe operation within the guidelines covered by legislation. Accordingly Mono Pumps Limited have declared the machine safe to use for the duty specified as defined by the Declaration of Incorporation or Conformity that is issued with this instruction manual.

The use of replacement parts that are not manufactured by or approved by Mono Pumps Limited may affect the safe operation of the pump and it may therefore become a safety hazard to both operators and other equipment. In these circumstances the Declaration provided will become invalid. The guarantee referenced on the Terms and Conditions of Sale will also be invalidated.

# Index

<b>SECTION 1</b>	<b>INSTALLATION</b>
	<b>START-UP PROCEDURE</b>
	<b>ASSEMBLY AND DISMANTLING ADVICE</b>
<b>SECTION 2</b>	<b>FAULT FINDING</b>
<b>SECTION 3</b>	<b>DRAWING REFERENCE NUMBERS</b>
	<b>PUMP CODING SHEET</b>
<b>SECTION 4</b>	<b>DISMANTLING AND ASSEMBLY DIAGRAMS</b>
	<b>EXPLODED VIEWS</b>
<b>SECTION 5</b>	<b>TORQUE TIGHTENING FIGURES</b>

## EC Declaration as defined by Machinery Directive 2006/42/EC.

The following harmonised standards are applicable: BS EN 809, BS EN ISO 12100 Parts 1 & 2

### EC Declaration of Incorporation

This declaration is only valid when partly completed machinery has been supplied.

In this case, the machinery meets the requirements of the said directive and is intended for incorporation into other machinery or for assembly with other machinery in order to constitute relevant machinery as defined by the said directive including any amendments, which are valid at the time of supply.

#### **IMPORTANT**

This machinery must not be put into service until the relevant machinery into which it is to be incorporated has been declared in conformity to the said directive.

This declaration is only valid when the machinery has been installed, operated and maintained in accordance with these instructions and safety guidelines contained within as well as instructions supplied for equipment assembled with or intended for use with this equipment.

### EC Declaration of Conformity

This declaration is not valid for partly completed machinery has been supplied.

In this case the machinery meets the requirements of the said directive including any amendments which are valid at the time of supply.

We further declare that, where applicable, said machinery also meets the requirements of:

The EMC Directive 2004/108/EC  
The Low Voltage Directive 2006 /95/E  
The Pressure Equipment Directive 97/23/EC  
The Outdoor Noise Directive 2005/88/EC  
The Drinking Water Directive 99/83/EC

#### **IMPORTANT**

This declaration is only valid when the machinery has been installed, operated and maintained in accordance with these instructions and safety guidelines contained within as well as instructions supplied for equipment assembled with or intended for use with this equipment.



**Mr C. Q. Griffiths - Engineering Services Manager.**  
**for Mono Pumps Limited, Martin Street, Audenshaw,**  
**Manchester England, M34 5JA**

# Installation, Operation & Maintenance Instructions

## INSTALLATION

### 1.1 INSTALLATION AND SAFETY RECOMMENDATIONS

In common with other items of process plant a pump must be installed correctly to ensure satisfactory and safe operation. The pump must also be maintained to a suitable standard. Following these recommendations will ensure that the safety of personnel and satisfactory operation of the pump is achieved.

#### 1.2.1. GENERAL

When handling harmful or objectionable materials, adequate ventilation must be provided in order to disperse dangerous concentrations of vapours. It is recommended that wherever possible, Mono pumps should be installed with provision for adequate lighting, thus ensuring that effective maintenance can be carried out in satisfactory conditions. With certain product materials, a hosing down facility with adequate draining will simplify maintenance and prolong the life of pump components.

Pumps operating on high temperature duties should be allowed to cool sufficiently before any maintenance is carried out.

#### 1.2.2. SYSTEM DESIGN & INSTALLATION

At the system design stage, consideration must be given to provision of filler plugs, and the installation of non-return and/or isolating valves. Pumps cannot be reliably used as non-return valves. Pumps in parallel and those with high static discharge head must be fitted with non-return valves.

The pumps must also be protected by suitable devices against over pressure and dry running.

#### i. HORIZONTAL MOUNTING

All ranges excluding P Range Mono pumps are normally installed in a horizontal position with baseplates mounted on a flat surface, grouted in and bolted, thus ensuring firm fixing and a reduction in noise and vibration.

The unit should be checked after bolting down to ensure that the alignment of the pump to its prime mover is correct.

#### ii. VERTICAL MOUNTING

P Range Pumps Only

The P range pumps are intended for vertical installation. Care must be taken when lifting the pump into the vertical position.

Normally 'P' range pumps will be designed with a sole plate that will be bolted to the customers framework.

If the pump is to be mounted in any way other than described above, confirmation of the installation must be agreed with Mono Pumps Limited. All the pipework should be independently supported.

### 1.3.1 HANDLING



During installation and maintenance, attention must be paid to the safe handling of all items. Where a pump or its components weigh in excess of 20 kg (45lb) it is recommended that suitable lifting tackle should be used to ensure that personal injury or damage to components does not occur.

For safe handling of both bareshaft pumps and pump units (pump/ gearbox/motor etc.) slings should be used. The position of the slings will depend upon the specific pump/unit construction and should be carried out by personnel with the relevant experience to ensure that the pump is not damaged and injury to personnel does not occur.

If eyebolts do exist then these should only be used for lifting the individual components for which they are supplied.

### 1.3.2 STORAGE AND INFREQUENT OPERATION

The situation where a pump is used infrequently is also covered by the instructions in this section.

#### SHORT TERM STORAGE

**Where a pump has to be stored for 6 months or less then the following steps are advised:-**

1. Store pump inside wherever possible or if this is not feasible then provide protective covering. Do not allow moisture to collect around the pump.
2. Remove the drain plug, if fitted. Any inspection plates fitted should also be removed to ensure that the suction housing can drain and dry completely.
3. Loosen the packed gland and inject sufficient grease into the stuffing box. Tighten the gland nut hand tight. If a water flush system is to be used do not grease, a small amount of light oil is recommended for these.
4. See Manufacturers Instructions for motor/gearbox/drive instructions for storage procedures.

# Installation, Operation & Maintenance Instructions

## LONG TERM STORAGE

**If the pump is to be kept in storage for more than six months then in addition to the above the following procedures should be carried out regularly (every 2 - 3 weeks if possible):**

1. If practicable rotate the pump at least three quarters of one revolution to avoid the rotor setting in the stator.
2. Note, however, that the pump is not to be rotated for more than two revolutions each time because damage could be caused to the rotor/ stator elements.

## IMMEDIATELY PRIOR TO INSTALLATION AND STARTING



**Before installing the pump please ensure that all plugs and inspection plates are replaced and that excess grease/oil is removed from the stuffing box.**

### 1.4 ELECTRICAL



Electrical connection should only be made using equipment suitable for both rating and environment. Where any doubts exist regarding the suitability of equipment, Mono Pumps Limited, should be consulted before proceeding. Normally the Mono pump should be installed with starting equipment arranged to give direct on line starting.

Earthing points will be provided on electric drives (if supplied) and it is essential that these are correctly connected. When the motor is being wired and checked for rotation, the start/stop sequence must be instantaneous to prevent dry running (see 2) or pressurising upstream equipment. (Check direction arrow on pump nameplate). The electrical installation should include appropriate isolating equipment to ensure that the pump unit is safe to work on.

### 1.5 PRESSURE RELIEF VALVES AND NON-RETURN VALVES

1. It is recommended that a suitable safety device is installed on the discharge side of the pump to prevent over-pressurisation of the system.
2. It is also recommended that a non-return valve is installed on the discharge side of the pump to prevent reverse flow through the system.

When both are installed it is advised that the relief valve is positioned closer to the pump than the non-return valve.

## IMPORTANT



**The pump must never run against a closed inlet or outlet valve, as this could result in mechanical failure.**

### 1.6 GENERAL SAFETY



**GREAT CARE MUST BE TAKEN TO PROTECT ALL ELECTRICAL EQUIPMENT FROM SPLASHING WHEN HOSING DOWN. WHERE MONO PUMPS LIMITED HAVE SUPPLIED A BARESHAFT PUMP THE ONUS IS ON THE USER TO FIT ADEQUATE GUARDS IN COMPLIANCE WITH THE REQUIREMENTS OF THE RELEVANT REGULATIONS.**

All nuts and bolts, securing flanges and base mounting fixtures must be checked for tightness before operation. To eliminate vibration, the pump must be correctly aligned with the drive unit, and all guards must be securely fixed in position. When commissioning the plant, all joints in the system must be checked thoroughly for leakage.

If, when starting, the pump does not appear to operate correctly (see 2), the plant must be shut down immediately and the cause of the malfunction established before operations are recommenced. It is recommended that depending upon plant system operation, either a combined vacuum and pressure gauge, or a vacuum gauge only be fitted to the pump inlet port, and a pressure gauge fitted to the outlet port, these will then continuously monitor the pump operating conditions. May contain substances from the ECHA SVHC Candidates List (REACH - Regulation (EC) No. 1907/2006)

### 1.7 DUTY CONDITIONS

Pumps should only be installed on duties for which Mono Pumps Limited have specified the materials of construction, flow rates, pressure, temperature, speed etc. Where dangerous materials are to be pumped, consideration must be given to the safe discharge from relief valves, gland drains etc.

**IF THE DUTY SHOULD BE CHANGED, MONO PUMPS LIMITED SHOULD BE CONTACTED AND THEIR RECOMMENDATIONS SOUGHT IN THE INTEREST OF APPLICATION, SAFETY OF PLANT, EFFICIENCY AND PUMP LIFE.**

# Installation, Operation & Maintenance Instructions

## 2. START-UP PROCEDURE

Pumps must be filled with liquid before starting. The initial filling is not for priming purposes, but to provide the necessary lubrication of the stator until the pump primes itself. When the pump is stopped, sufficient liquid will normally be trapped in the rotor/stator assembly to provide lubrication upon re-starting.

If, however, the pump has been left standing for an appreciable time, moved to a new location, or has been dismantled and re-assembled, it must be refilled with liquid and given a few turns before starting. The pump is normally somewhat stiff to turn by hand owing to the close rotor/stator fit. However, this stiffness disappears when the pump is running normally against pressure.

### 2.1 DRY RUNNING



**NEVER RUN THE PUMP IN A DRY CONDITION EVEN FOR A FEW REVOLUTIONS OR THE STATOR WILL BE DAMAGED IMMEDIATELY. CONTINUAL DRY RUNNING COULD PRODUCE SOME HARMFUL OR DAMAGING EFFECTS.**

### 2.2 PUMP ROTATION DETAILS

<u>PUMP RANGE</u>	<u>BI-DIRECTIONAL</u>	<u>COMMENT</u>
Epsilon	Yes	†
E	Yes	†
Monobloc B	Yes	†
Compact	Yes	†
Merlin Industrial	Yes	†
S, SL	Yes	†
LF	Yes	†
W	No	**
Merlin Widethroat	No	**
MM ML	No	*
MS	No	**
G	No	*
CB/SB	No	*
Placer	No	**
Grout Injection	No	**
P	No	*
CP0011	No	**
CP0025,CP0800,CP1600	No	*

\* Clockwise when viewed from drive end.

\*\* Anti-clockwise when viewed from drive end.

† Anti-clockwise gives inlet at drive end.

### DIRECTIONS OF ROTATION



**BEFORE THE DIRECTION OF ROTATION IS CHANGED, MONO PUMPS LIMITED MUST BE CONSULTED SO THAT THE SUITABILITY OF THE PUMP CAN BE CONFIRMED WHEN OPERATING ON THE NEW DUTY.**

### 2.3.1. GLAND PACKING

Where a pump is supplied fitted with gland packing (manufactured from a non-asbestos material), the gland will require adjustment during the initial running in period. Newly packed glands must be allowed to run-in with only finger tight compression on the gland follower nuts. This should continue for about 3 days. The gland follower should be gradually tightened over the next week to achieve a leakage rate as shown in the table below. Gland followers should be adjusted at regular intervals to maintain the recommended leakage flow rate. Under normal working conditions a slight drip from the gland under pressure assists in cooling and lubricating the packing. **A correctly adjusted gland will always have small leakage of fluid.**

#### Typical Leakage Rates from Packed Glands

<u>Up to 50mm shaft diameter</u>	<u>2 drops per minute</u>
<u>50 ... 75mm shaft diameter</u>	<u>3 drops per minute</u>
<u>75 ... 100mm shaft diameter</u>	<u>4 drops per minute</u>
<u>100 ... 125mm shaft diameter</u>	<u>5 drops per minute</u>
<u>125 ... 160mm shaft diameter</u>	<u>6 drops per minute</u>

A gland drip is, however, undesirable when handling corrosive, degreasing, or abrasive materials. Under these conditions the gland must be tightened the minimum amount whilst the pump is running to ensure satisfactory sealing when under pressure, or to stop entry of air when under suction conditions.

The gland leakage of toxic, corrosive or hazardous liquids can cause problems of compatibility with the pumps materials of construction.

Provision of a gland drain should be considered, especially for the leakage of hazardous products.



**CARE IS REQUIRED WHEN ADJUSTING THE GLAND WHILST PUMP IS RUNNING.**

### 2.3.2 MECHANICAL SEALS - ALL PUMPS

When a mechanical seal is fitted to the pump it may be necessary to provide a barrier fluid to some part of the seal. This should be provided in line with the seal manufacturers instructions.

### 2.4. GUARDS



In the interests of safety, and in accordance with the U.K. Health and Safety at Work Act 1974, all guards must be replaced after necessary adjustments have been made to the pump.

# Installation, Operation & Maintenance Instructions

## 2.5 WARNING/CONTROL DEVICE

Prior to operating the pump, if any warning or control devices are fitted these must be set in accordance with their specific instructions.

## 2.6 PUMP OPERATING TEMPERATURE

The range of temperatures the pump surfaces will develop is dependent upon factors such as product temperature and ambient temperature of the installation. There may be instances where the external pump surface can exceed 50°C.

In these instances, personnel must be made aware of this and suitable warnings/guarding used.

## 2.7 NOISE LEVELS

1. The sound pressure level should not exceed 85dB at one metre distance from the pump.
2. This is based on a typical installation and does not necessarily include noise from other sources or any contribution from building reverberation or installation pipework
3. It is recommended the actual pump unit noise levels are ascertained once the unit is installed and running at duty conditions

## 2.8 LUBRICATION

Pumps fitted with bearings should be inspected periodically to see if grease replenishment is necessary, and if so, grease should be added until the chambers at the ends of the bearing spacer are approximately one third full.

Periodic bearing inspection is necessary to maintain optimum bearing performance. The most expedient time to inspect is during periods of regular scheduled equipment downtime - for routine maintenance or for any other reason.

Under tropical or other arduous conditions, however, a more frequent examination may be necessary. It is therefore advisable to establish a correct maintenance schedule or periodic inspection.

BP LC2 / Mobilgrease XHP 222 or their equivalent must be used for replenishment.

## 2.9 PUMP UNITS

Where a pump unit is dismantled and re-assembled, consideration must be given to ensure that where appropriate the following steps are covered.

1. Correct alignment of pump/gearbox
2. Use of appropriate couplings & bushes
3. Use of appropriate belts & pulleys correctly tensioned.

## 2.10 CLEANING PRIOR TO OPERATION

### i. Non Food Use

During the commissioning of a new pump or recommissioning of an overhauled pump, it is advisable to clean the pump prior to the initial operation of the pump in the process.

### ii. Food Use

When a pump has been supplied for a food application, it is important to ensure that the pump is clean prior to initial operation of the pump.

Therefore, it is important that a clean-in-place treatment is executed on the pump at the following times:-

1. When the pump is first commissioned for use.
2. When any spare components are fitted into the wetted area of the pump.

A recommended CIP procedure is as follows:

**This procedure should not be used on the CP Pump Range. Please consult our application engineers for a suitable procedure.**

### Caustic Wash

LQ94 ex Lever Diversey or equivalent  
2% concentration

### Acid Wash

P3 Horolith 617 ex Henkel  
Ecolab or equivalent 1% concentration

### Procedure

1. Caustic wash @ 75°C for 20 mins
2. Water rinse @ 80°C for 20 mins

# Installation, Operation & Maintenance Instructions

3. Acid wash @ 50°C for 20 mins
4. Water rinse @ 80°C for 20 mins

- CIP flow rates (hence pump speeds) should be maximised to achieve highest level of cleanability.

A C.I.P. liquid velocity of 1.5 to 2.0 m/s is required for removal of solids and soiling.

Pumps fitted with CIP by pass ports will permit higher flow rates without the need to increase pump speed.

- The use of neat active caustic and acid chemicals is not recommended. Proprietary cleaning agents should be used in line with manufacturers instructions.
- All seals and gaskets should be replaced with new if disturbed during maintenance.
- Pump internals should be regularly inspected to ensure hygienic integrity is maintained, especially with respect to elastomeric components and seals, and replaced if necessary.

The four stages constitute one cycle and we recommend that this cycle is used to clean the pump before use on food.

Once the pump has been commissioned, the cleaning process will depend upon the application. The user must therefore ensure that their cleaning procedures are suitable for the duty for which the pump has been purchased.

## 2.11 WIDETHROAT PUMPS

Specific pumps may have auger feed screws, with or without a bridge breaker system to feed the pumping element. If the pump installation requires that these cannot be enclosed, care must be taken to ensure personnel cannot gain access whilst the pump is operating. If this is not possible an emergency stop device must be fitted nearby.

## 2.12 EXPLOSIVE PRODUCTS/ HAZARDOUS ATMOSPHERES

In certain instances the product being pumped may well be of a hazardous nature.

In these installations consideration must be given to provide suitable protection and appropriate warnings to safeguard personnel and plant.

## 2.13 ACCESS PORTS



Where access ports are fitted then the following steps must be followed prior to removal:

1. Pump must be shut down and the electrical supply isolated.
2. Protective clothing should be worn, especially if the pumped product is obnoxious.
3. Remove access plate with care utilising where possible drip trays to collect product leakage.

Access ports are included to assist in removing blockages and to allow a visual check on the components within the suction chamber.

It is not to be considered as an additional method in dismantling the pump.

Re-assembly of the plate should be completed using new gaskets prior to the pump being switched on.

## 2.14 ADJUSTABLE STATORS

If adjustable stators are fitted then the following steps must be followed for adjusting the clamping devices.

The adjustable stator assembly is designed to give an even compression around the stator circumference. It is designed to be used when pump performance reduces through wear to an unacceptable level, to restore the required flow rate.

The stator compression is increased using the following steps:-

1. Release the six locking screws half a turn.
2. Tighten the eight clamp screws until adjustment allowed by releasing the lock screws has been taken up.
3. Repeat steps 1 and 2 until the pump performance has been restored to its former level.

### NOTE

It is imperative that when adjusting the stator that only sufficient pressure is placed on the stator to enable the capacity of the pump to be reinstated.

Over tightening of the stator could easily result in damage to the driver by overload and so extreme care must be taken when carrying out these adjustments.

# Installation, Operation & Maintenance Instructions

It is therefore advisable to make the adjustment while the pump is running and power readings can be monitored.

## REMOVAL OF ADJUSTABLE STATOR

The procedure for removal of an adjustable stator is the same as that of a standard one, except it is necessary to remove the clamp plates before the stator can be twisted off the rotor.

This can be done by undoing the clamp screws; then releasing the clamp plate by using the locking screws as jacking screws to remove the clamp plates.

Re-assembly will be done using the reverse procedure.

## 2.15 MAINTENANCE OF WEARING COMPONENTS

### 2.15.1 ROTOR AND STATOR

The wear rate on these components is dependent on many factors, such as product abrasivity, speed, pressure etc.

When pump performance has reduced to an unacceptable level one or possibly both items will need replacing.

### 2.15.2 DRIVE SHAFT - PACKED GLAND

The wear rate of the gland area is dependent on many factors such as product abrasivity and speed. Regular gland maintenance will maximise the life of the shaft. Replacement of both the gland packing and shaft will be necessary when shaft sealing becomes difficult to achieve.

### 2.15.3 COUPLING ROD JOINTS

Regular maintenance and lubrication will maximise life of the joints.

Replacement of one or both joint assemblies and possibly the coupling rod may be necessary when wear is apparent.

It is essential to replace all the joint items with genuine Mono parts to ensure maximum life.

## 2.15.4 FLEXISHAFT DRIVE PUMPS

With this design there are no wearing items to replace in the drive train, however, if during routine inspection the shaft is visibly damaged / distorted or the protective coating is damaged, then this item should be replaced to avoid unexpected breakdowns.

## 2.16 MECHANICAL SPEED VARIATORS

Refer to the manufacturers instructions.

These machines require regular maintenance, which typically includes weekly adjustment through the full speed range.

## 3.0 ASSEMBLY AND DISMANTLING

Section 4 contains the steps to dismantle and re-assemble the pump. All fastenings must be tightened securely and when identified the appropriate torque figures should be used.

## 3.1 USE OF ITEMS NOT APPROVED OR MANUFACTURED BY MONO PUMPS LIMITED

The pump and its components have been designed to ensure that the pump will operate safely within the guidelines covered by the legislation.

As a consequence Mono Pumps Limited have declared the machine safe to use for the duty specified as defined by the Declaration of Incorporation or Conformity that is issued with this Instruction Manual.

The use of replacement items that are not approved by or manufactured by Mono Pumps Limited may affect the safe operation of the pump and it may therefore become a safety hazard to both operators and other equipment. In these instances the Declaration provided will therefore become invalid. The guarantee referenced in the Terms and Conditions of Sale will also be invalidated if replacement items are used that are not approved or manufactured by Mono Pumps Limited.



## DISPOSAL OF WORN COMPONENTS

*When replacing wearing parts, please ensure disposal of used parts is carried out in compliance with local environmental legislation. Particular care should be taken when disposing of lubricants.*

# Installation, Operation & Maintenance Instructions

## 3.2 RECOMMENDED LIFTING POINTS

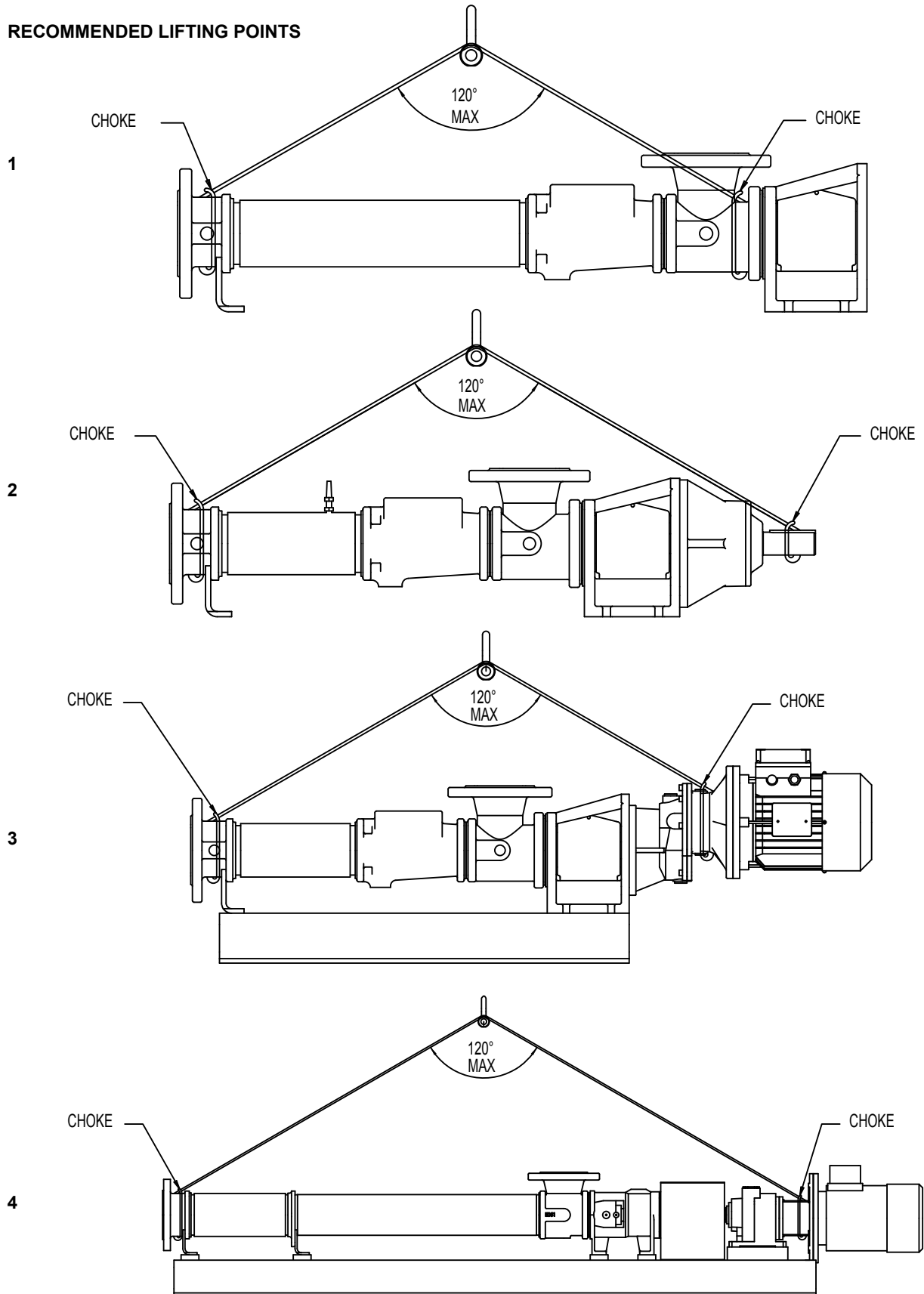

# Installation, Operation & Maintenance Instructions

## 3.3 PUMP AND WEAR PARTS WEIGHTS.

**NOTE:** Weights are for guidance purpose only. Please refer to the documentation issued with your pump or spares.

### Epsilon

Model	Weight (kg)					
	Bloc Pump	Bareshaft Pump	Stator	Rotor	Flexishaft	Shaft
E11B	13	18	1.24	0.55	0.09	0.48
E11D	14	19	2.6	0.76	0.09	0.48
E12A	12	18	2.59	0.55	0.09	0.48
E12B	14	20	2.53	0.76	0.09	0.48
E12D	23	29	5.5	1.58	0.14	0.48
E13A	16	22	1.24	0.83	0.14	0.48
E13B	19	24	2.51	1.48	0.14	0.48
E13D	n/a	35	5.13	2.88	0.27	1.85
E13K	19	24	2.51	1.36	0.14	0.48
E1XA	28	33	2.1	1.78	0.13	0.48
E1XB	35	39	5.5	4.66	0.27	1.45
E1XD	n/a	56	10.39	5.51	1	2.24
E1XK	n/a	33	5.5	2.7	0.13	0.48
E14A	38	59	3.54	4.53	1.27	1.71
E14B	51	72	7.05	5	1	1.71
E14D	n/a	79	14.01	9.1	1.96	3.3
E14K	52	73	7.12	4.8	0.8	1.71
E15A	58	79	6.31	4.94	1	1.71
E15B	86	107	12.38	9.1	2.2	3.12
E15D	n/a	115	24.53	17.98	3.98	5.43
E15K	65	86	13	4.94	1	1.71
E16A	90	111	11	8.4	2.2	3.12
E16B	118	149	21.49	15.44	3.7	4.3
E16D	n/a	181	42.53	30.15	7.6	8.3
E16K	107	128	5	8.4	2.2	3.12
E17A	126	162	17.36	13.31	3.7	4.3
E17B	172	208	34.27	27.1	4.4	4.3
E17D	n/a	315	68	48.85	8	16.79
E17K	169	205	34.25	17.86	3.7	4.3
E18A	133	183	23.09	17.86	4.4	4.3
E18B	195	252	24.64	33.73	7.2	4.7
E18D	n/a	432	93	64.72	11.3	16.79
E18K	192	242	45.01	17.86	4.4	4.3
E19A	215	275	41.66	47.63	7.2	4.7
E19B	326	386	65.93	47.63	7.2	4.7
E19K	310	370	67.19	47.63	7.2	4.7
E1AA	258	318	37.36	38.83	9.3	4.7
E1AB	409	479	74.36	72.4	13.8	4.7
E1AD	n/a	765	2 x E1AB	174	19.5	23
E1AK	344	414	74.43	38.83	9.3	4.7
E1BA	421	491	64.49	126.84	11.1	4.7
E1BB	n/a	615	129.99	139.39	19.01	22.97
E1BD	n/a	1511	2 x E1BB	320	39.9	52
E1BK	542	612	122.86	131	13.8	4.7
E1CA	n/a	575	92	136.39	24	23
E1CB	n/a	1350	2 x E1CA	307.36	52	51
E1DA	n/a	675	121	178	24	23
E1EA	n/a	1625	421	321	55	52

# Diagnostic Chart

SYMPTOMS	POSSIBLE CAUSES
1. NO DISCHARGE 2. LOSS OF CAPACITY 3. IRREGULAR DISCHARGE 4. PRIMING LOST AFTER START 5. PUMP STALLS AT START UP 6. PUMP OVERHEATS 7. MOTOR OVERHEATS 8. EXCESSIVE POWER ABSORBED BY PUMP 9. NOISE AND VIBRATION 10. PUMP ELEMENT WEAR 11. EXCESSIVE GLAND OR SEAL WEAR 12. GLAND LEAKAGE 13. SEIZURE	1. 2. 3. 7. 26. 28. 29. 3. 4. 5. 6. 7. 8. 9. 10. 22. 13. 16. 17. 21. 22. 23. 29 3. 4. 5. 6. 7. 8. 13. 15. 29. 3. 4. 5. 6. 7. 8. 13. 15 8. 11. 24. 8. 9. 11. 12. 18. 20 8. 11. 12. 15. 18. 20. 8. 11. 12. 15. 18. 20 3. 4. 5. 6. 7. 8. 9. 11. 13. 15. 18. 19. 20. 22. 23. 27. 31 9. 11. 12. 14. 25. 30. 13. 14. 9. 11. 12. 20.
LIST OF CAUSES	REMEDIAL ACTIONS
1. INCORRECT DIRECTION OF ROTATION 2. PUMP UNPRIMED 3. INSUFFICIENT N.P.S.H. AVAILABLE 4. PRODUCT VAPORISING IN SUPPLY LINE 5. AIR ENTERING SUPPLY LINE 6. INSUFFICIENT HEAD ABOVE SUPPLY VESSEL OUTLET 7. FOOTVALVE/STRAINER OBSTRUCTED OR BLOCKED 8. PRODUCT VISCOSITY ABOVE RATED FIGURE 9. PRODUCT TEMP. ABOVE RATED FIGURE 10. PRODUCT VISCOSITY BELOW RATED FIGURE 11. DELIVERY PRESSURE ABOVE RATED FIGURE 12. GLAND OVERTIGHT 13. GLAND UNDERTIGHT 14. GLAND FLUSHING INADEQUATE 15. PUMP SPEED ABOVE RATED FIGURE 16. PUMP SPEED BELOW RATED FIGURE 17. BELT DRIVE SLIPPING 18. COUPLING MISALIGNED 19. INSECURE PUMP/DRIVE MOUNTING 20. SHAFT BEARING WEAR/FAILURE 21. WORN PUMP ELEMENT 22. RELIEF VALVE CHATTER 23. R.V. INCORRECTLY SET 24. LOW VOLTAGE 25. PRODUCT ENTERING PACKING AREA 26. DRIVE TRAIN BREAKAGE 27. NEGATIVE OR VERY LOW DELIVERY HEAD 28. DISCHARGE BLOCKED/VALVE CLOSED 29. STATOR TURNING 30. STUFFING BOX 'EATS' PACKING 31. VEE BELTS	1. REVERSE MOTOR 2. BLEED SYSTEM OF AIR/GAS 3. INCREASE SUCTION HEAD OR REDUCE SPEED/TEMP. 4. INCREASE N.P.S.H. AVAILABLE (SEE 3 ABOVE) 5. CHECK PIPE JOINTS/GLAND ADJUSTMENT 6. RAISE VESSEL/INCREASE PIPE SIZE 7. CLEAN OUT SUCTION LINE/VALVES 8. DECREASE PUMP SPEED/INCREASE TEMP. 9. COOL THE PRODUCT 10. INCREASE PUMP SPEED/REDUCE TEMP. 11. CHECK FOR BLOCKAGES IN DELIVERY LINE 12. ADJUST GLAND SEE O&M INSTRUCTIONS 13. ADJUST GLAND SEE O&M INSTRUCTIONS 14. CHECK FLUID FLOWS FREELY INTO GLAND 15. DECREASE PUMP SPEED 16. INCREASE PUMP SPEED 17. RE-TENSION BELTS 18. CHECK AND ADJUST ALIGNMENT 19. CHECK AND TIGHTEN ALL PUMP MOUNTINGS 20. REPLACE BEARINGS 21. FIT NEW PARTS 22. CHECK CONDITION OF VALVE/RENEW 23. RE-ADJUST SPRING COMPRESSION 24. CHECK VOLTAGE/WIRING SIZES 25. CHECK PACKING CONDITION AND TYPE 26. CHECK AND REPLACE BROKEN COMPONENTS 27. CLOSE DELIVERY VALVE SLIGHTLY 28. REVERSE PUMP/RELIEVE PRESSURE/CLEAR BLOCKAGES 29. REPLACE WORN PARTS/TIGHTEN UP STATOR BOLTS 30. CHECK FOR WORN SHAFT AND REPLACE 31. CHECK AND ADJUST TENSION OR REPLACE

# Drawing Reference Numbers

<u>DRG. REF</u>	<u>DESCRIPTION</u>	<u>DRG. REF</u>	<u>DESCRIPTION</u>
01A	BODY	P201	TAPER PLUG
01B	BODY ADAPTOR	P202	TAPER PLUG
06A	NAMEPLATE (SOG)		
06B	NAMEPLATE (DOG)		
08A	GLAND	P401	TOROIDAL SEAL RING
10A	MECHANICAL SEAL / GLAND PACKING	P402	TOROIDAL SEAL RING
10B	ROTARY SHAFT LIPSEAL (OPTIONAL)	P403	TOROIDAL SEAL RING
15A	THROWER GUARD	P404	TOROIDAL SEAL RING
20B	GASKET - GLAND		
20C	GASKET - GLAND		
20D	GASKET - SUCT. CHAMBER/EXT	P501	TAPER PLUG
22A	STATOR	P502	TAPER PLUG
23A	SUCTION CHAMBER	P503	STL. HEX. NUT
23B	SUCTION CHAMBER EXTENSION - INSPECTION PORT	P504	STL. BRIGHT WASHER
23C	SUCTION CHAMBER EXTENSION TUBE	P505	SINGLE COIL SPRING WASHER
24A	END COVER	P506	STL. HEX. NUT
25A	ROTOR	P507	STL. BRIGHT WASHER
26A	FLEXISHAFT	P508	SINGLE COIL SPRING WASHER
27A	DRIVE CLAMP	P509	TOROIDAL SEAL RING
27B	DRIVE CLAMP PIN	P510	TOROIDAL SEAL RING
29C	SHAFT PIN	P511	TOROIDAL SEAL RING
32A	DRIVE SHAFT	P512	STL. HEX. HD. BOLT
42A	THROWER	P513	CLAMP BOLTS
62A	SUPPORT FOOT	P514	SINGLE COIL SPRING WASHER
65A	MECH SEAL CARRIER / GLAND SELECTION	P515	STL.HEX.NUT
66A	ABUTMENT RING	P516	STL. HEX. HD. BOLT
75A	SLEEVE	P517	STL. HEX. HD. BOLT
76A	ADAPTOR FLANGE	P519	TAPER PLUG
95A	TIE BARS - STATOR	P523	STL. STUD
95B	TIE BARS - SUCTION CHAMBER EXTENSION TUBE	P524	SINGLE COIL SPRING WASHER
P104	STL. HEX. HD. BOLT	P525	STL. BRIGHT WASHER
P105	STL. HEX. NUT	P526	STL.HEX.NUT
P106	STL. BRIGHT WASHER	P527	STL.STUD
P107	SINGLE COIL SPRING WASHER	P528	STL.BRIGHT WASHER
P109	STL. HEX. NUT	P529	SINGLE COIL SPRING WASHER
		P530	STL. HEX NUT
		P601	STL.HEX. HD. BOLT
		P602	SINGLE COIL SPRING WASHER
		P603	STL. BRIGHT WASHER
		P604	STL.HEX. NUT

## IMPORTANT NOTE

THE DRAWING REFERENCES SHOWN GIVE THE DESCRIPTION OF ALL THE PARTS DETAILED ON THE SECTIONAL DRAWINGS IN THIS SECTION OF THE BOOK. THEREFORE SOME OF THE REFERENCES MAY NOT BE SHOWN ON ANY ONE.

# Pump Coding

Features	Description	Basic Pump Code										Standard Variation								
		1	2	3	4	5	6	7	8	9	10	/	12	13	14	15				
Range	Epsilon	E																		
Design Mk No	2007		1																	
Maximum Pump Capacity at Maximum Speed and Zero Pressure	1.3m³/h @ 1750 rpm			1																
	3.3m³/h @ 1750 rpm			2																
	10m³/h @ 1500 rpm			3																
	13m³/h @ 1500 rpm			X																
	22m³/h @ 1000 rpm			4																
	37m³/h @ 800 rpm			5																
	57m³/h @ 700 rpm			6																
	79m³/h @ 600 rpm			7																
	97m³/h @ 500 rpm			8																
	125m³/h @ 450 rpm			9																
	165m³/h @ 400rpm			A																
	225m³/h @ 350 rpm			B																
	210m³/h @ 270 rpm			C																
	290m³/h @ 270 rpm			D																
	420m³/h @ 200 rpm			E																
Stages	Single stage				A															
	Two stage				B															
	Four stage				D															
	Single stage - extended pitch				K															
Casing Material	Cast Iron					C														
	Stainless steel					S														
Rotating Parts	Code 1							1												
	Code 5							5												
	Code 8							8												
Rotor Mk No	Mk 0 (Oversized)								0											
	Mk1 (Standard)								1											
	Mk3 (Temperature)								3											
	Mk5 (Temperature)								5											
Stator Material	RA, RR etc.										R									
Flexishaft / Seal Type	Mechanical Seal - St Stl Flexishaft											M								
	Packed Gland - St. Stl Flexishaft											P								
	Mechanical Seal - Titanium Flexishaft											R								
	Packed Gland - Titanium Flexishaft											S								
Build Option	Refer to product manual section 2 & 3, drive selections											A								
												B								
												H								
/												/								
Variation	For special requirements contact Mono Pumps Ltd														A	1	2	3		

# Dismantling & Assembly Diagrams

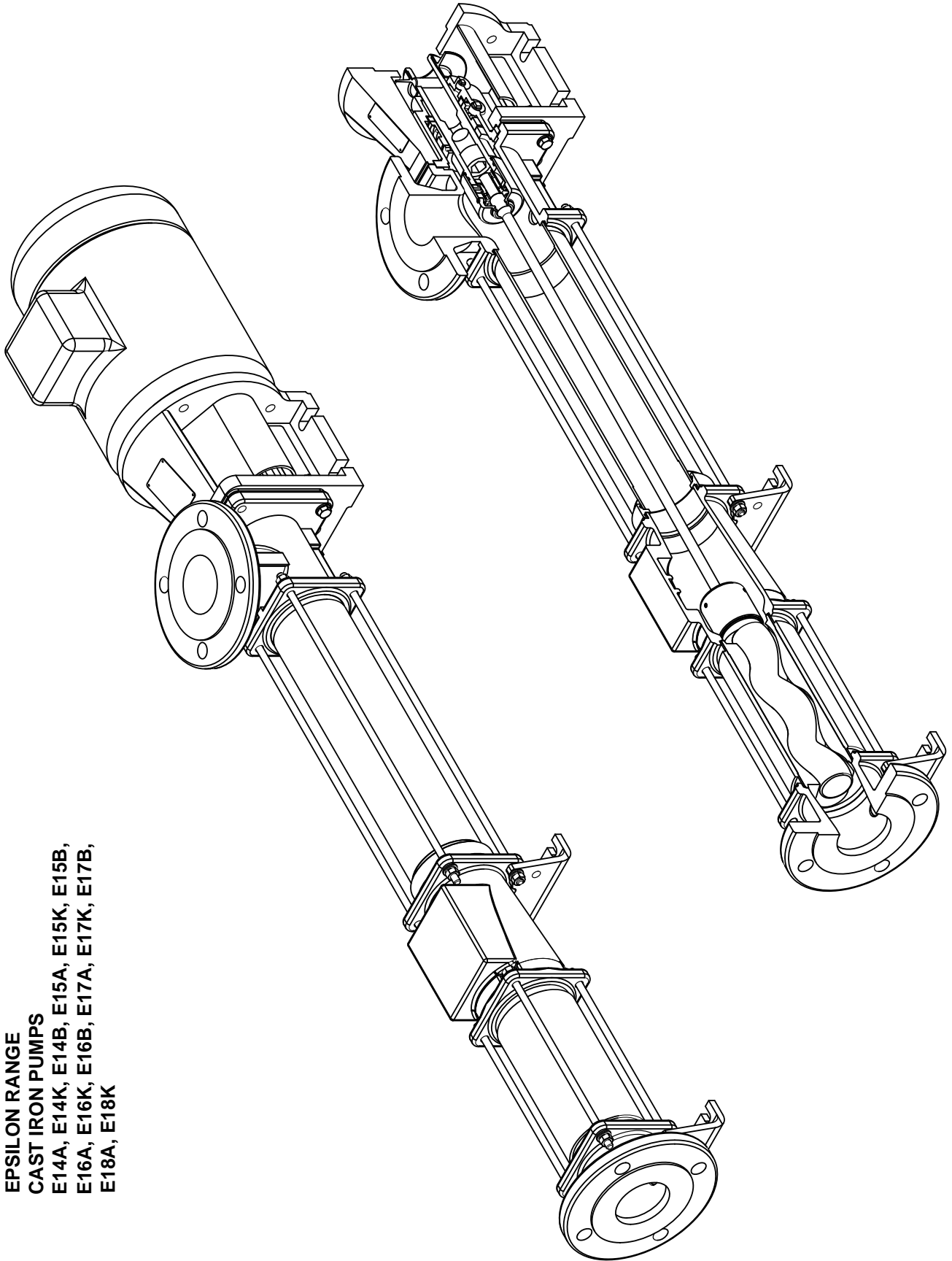

EPSILON RANGE  
CAST IRON PUMPS  
E14A, E14K, E14B, E15A, E15K, E15B,  
E16A, E16K, E16B, E17A, E17K, E17B,  
E18A, E18K

# Dismantling & Assembly Diagrams

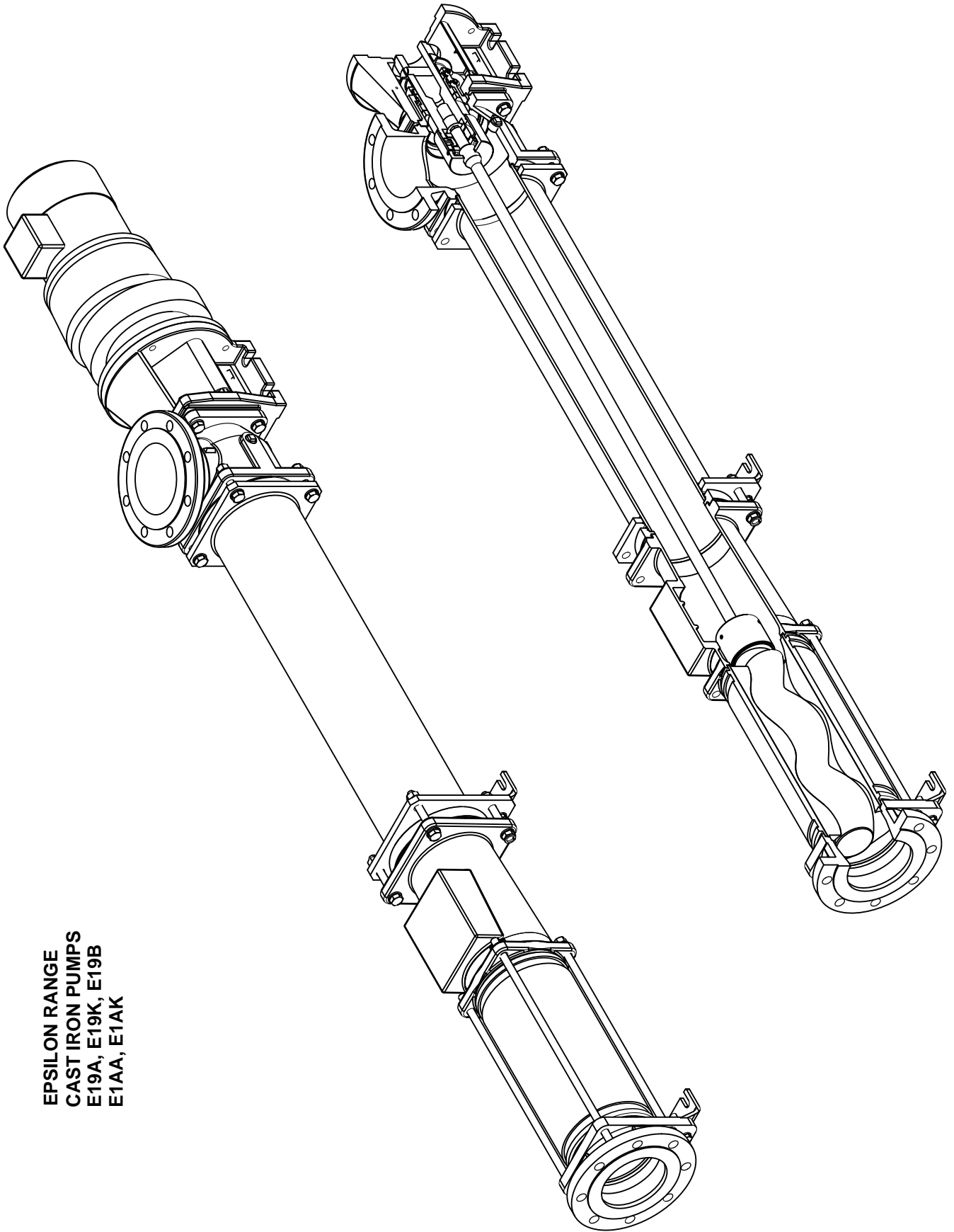

EPSILON RANGE  
CAST IRON PUMPS  
E19A, E19K, E19B  
E1AA, E1AK

# Dismantling & Assembly Diagrams

DISMANTLING PROCEDURE

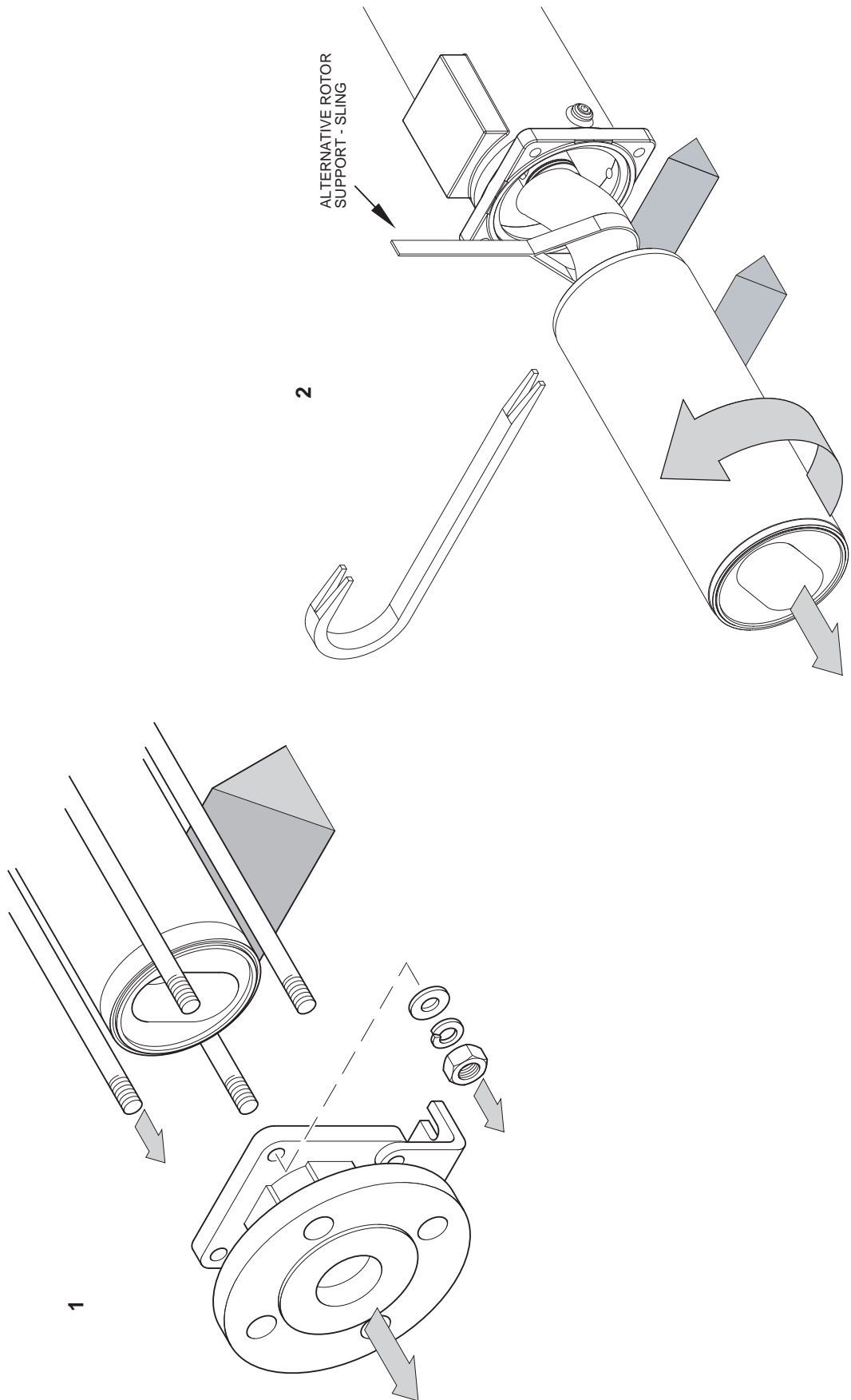

# Dismantling & Assembly Diagrams

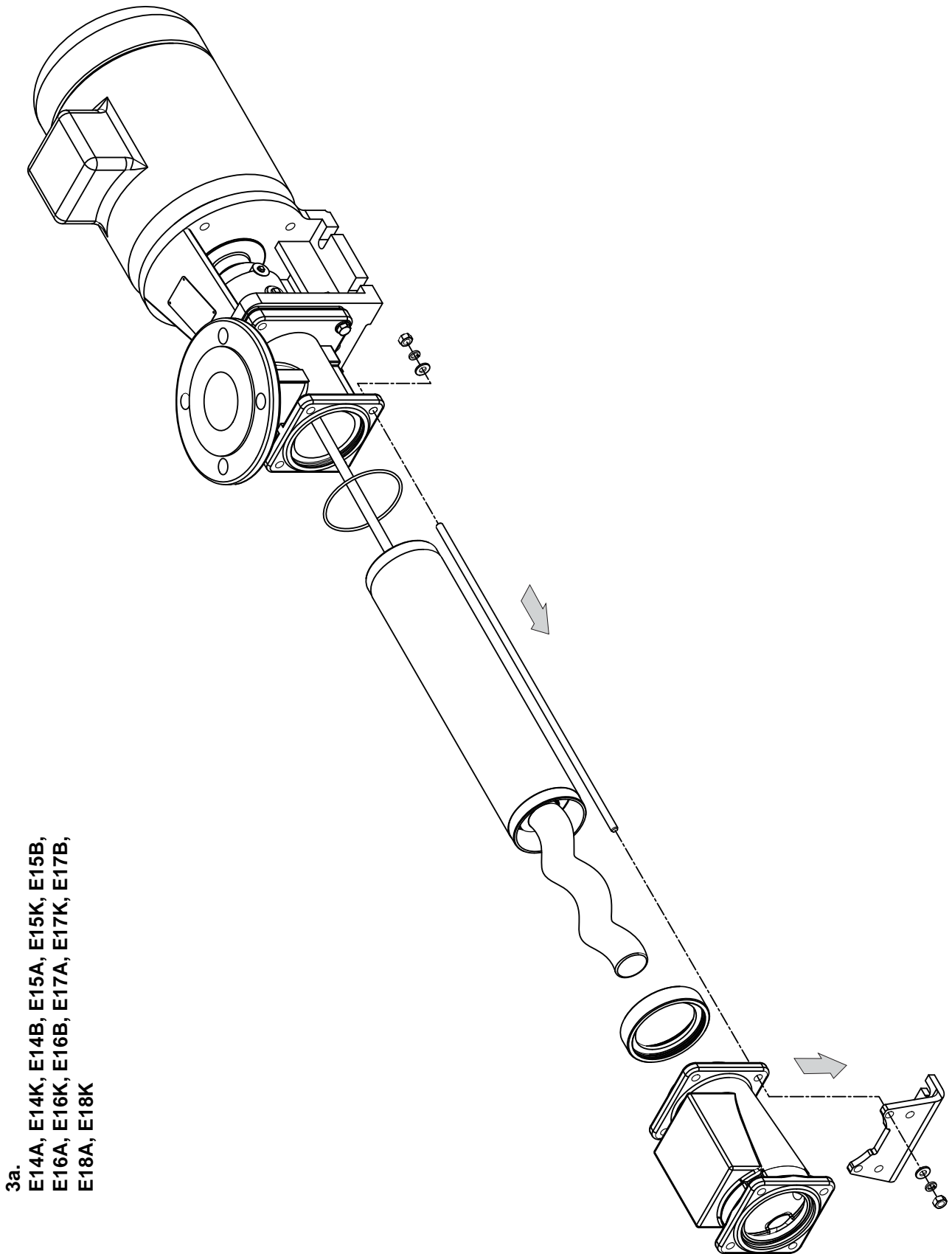

# Dismantling & Assembly Diagrams

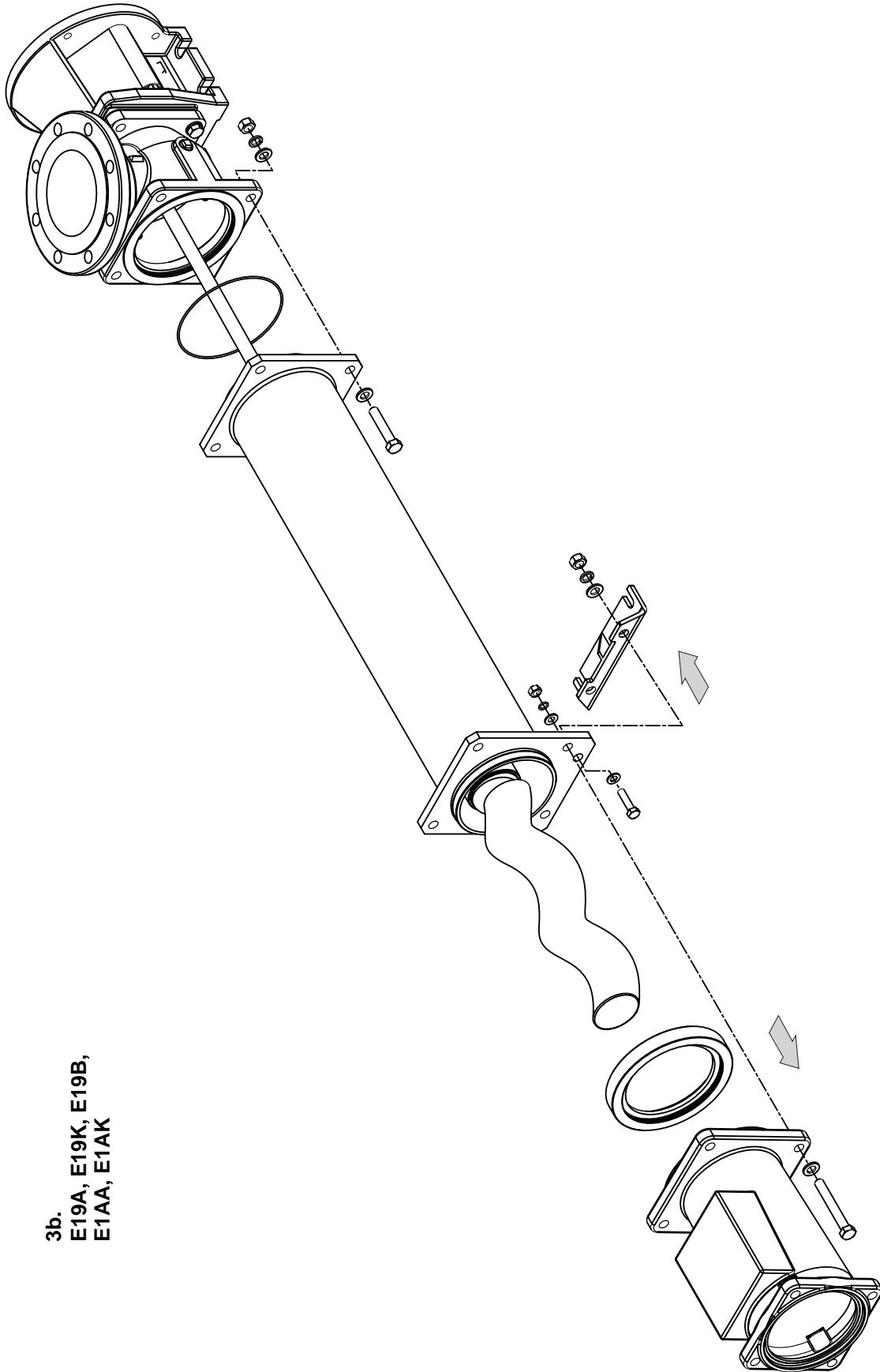

3b.  
E19A, E19K, E19B,  
E1AA, E1AK

# Dismantling & Assembly Diagrams

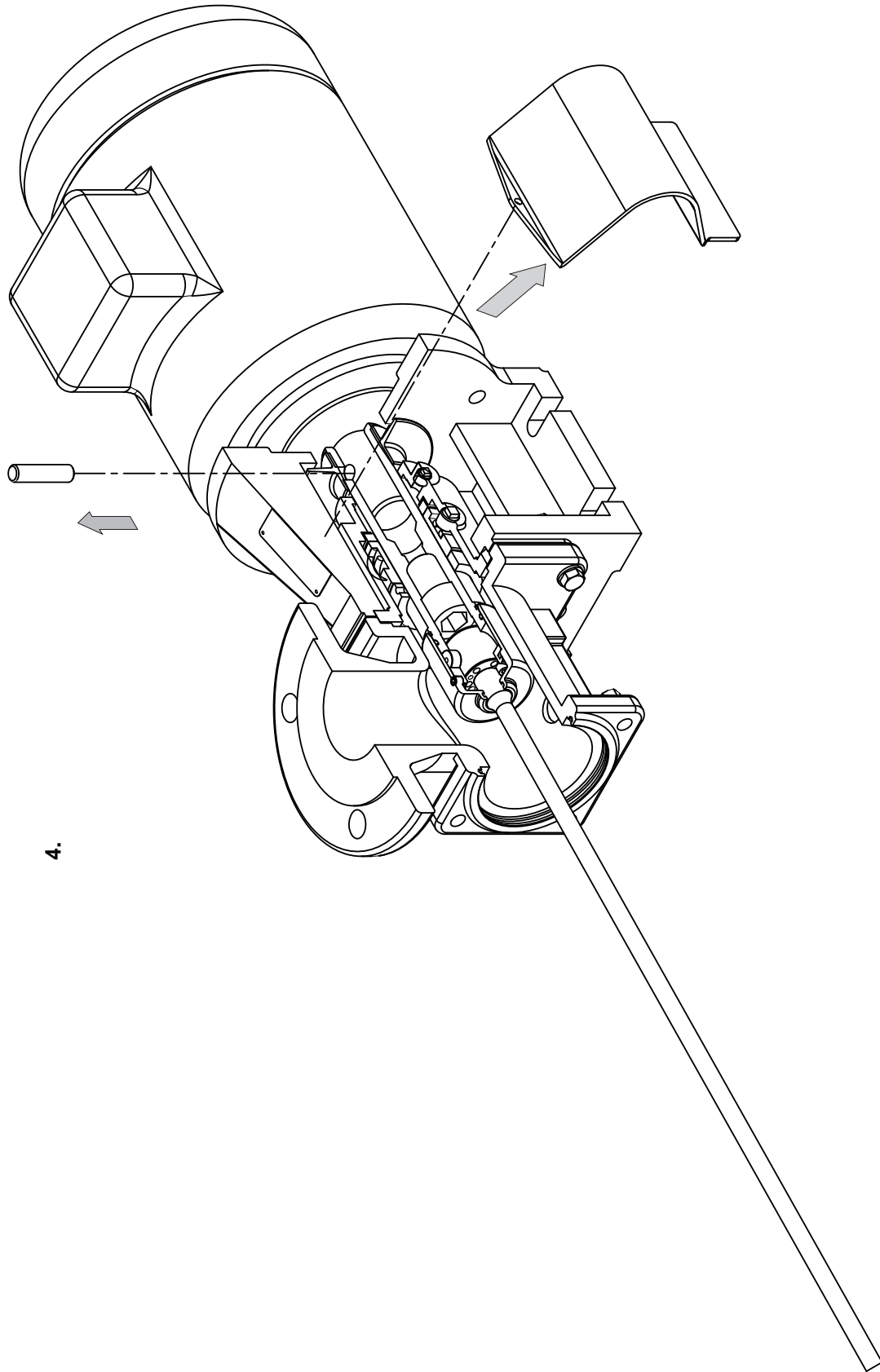

4.

# Dismantling & Assembly Diagrams

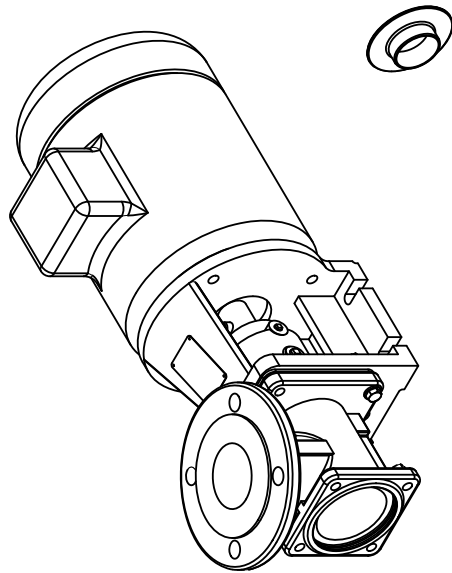

5a.

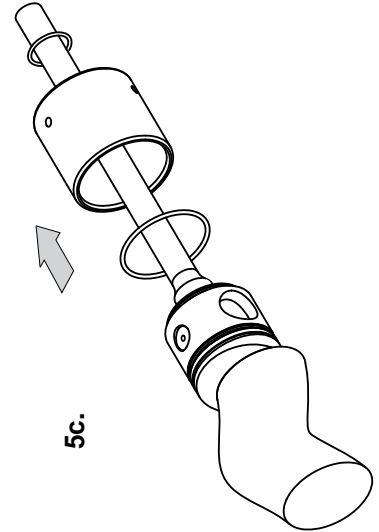
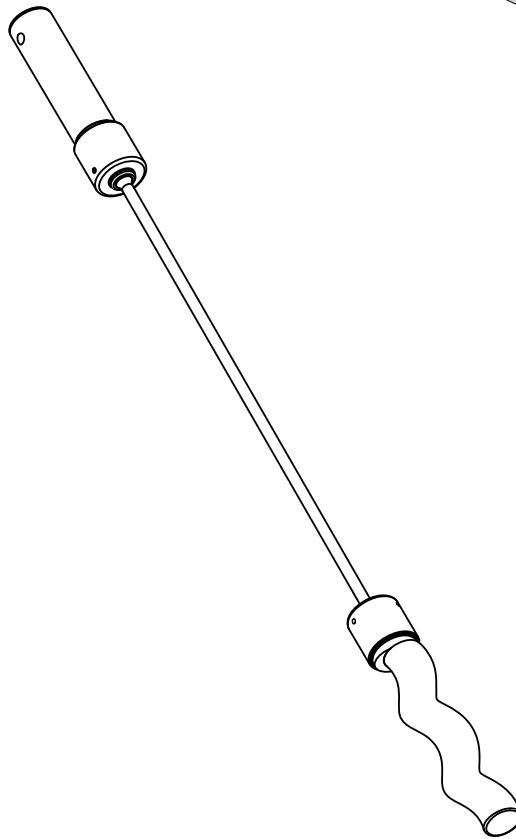

5c.

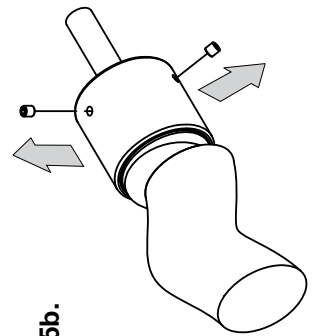

5b.

# Dismantling & Assembly Diagrams

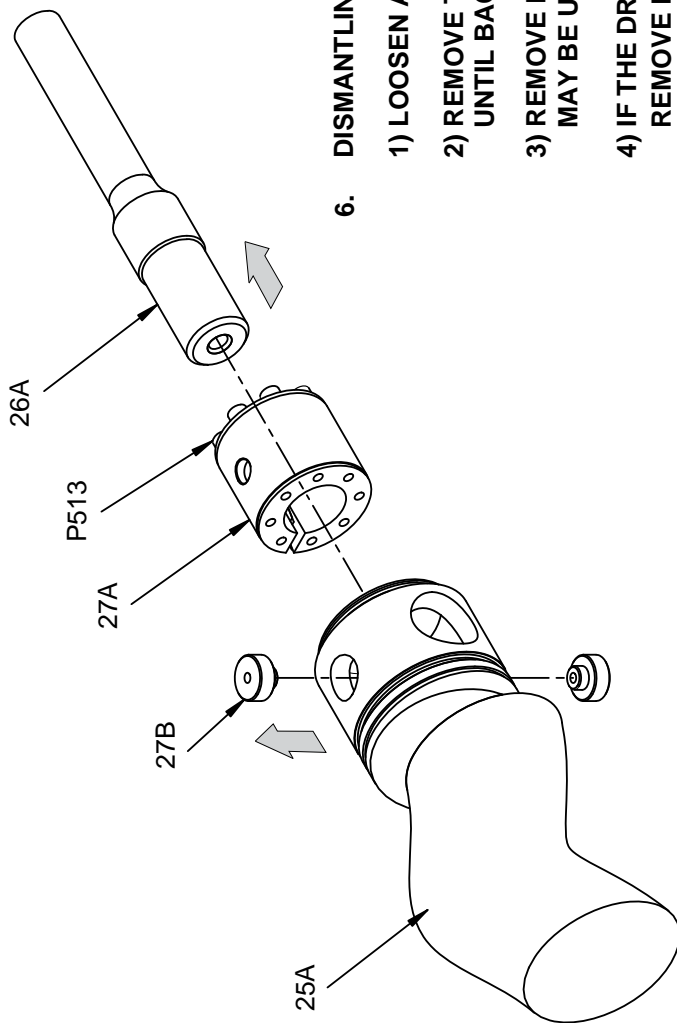

## 6. DISMANTLING NOTES

- 1) LOOSEN ALL DRIVE CLAMP BOLTS (P513)
- 2) REMOVE TWO BOLTS (P513) AND SCREW INTO HOLES A & B UNTIL BACK TAPER IS BROKEN
- 3) REMOVE DRIVE CLAMP PINS (27B) DRIVE CLAMP BOLTS (P513) MAY BE UTILISED IF NECESSARY.
- 4) IF THE DRIVE CLAMP (27A) IS STILL LOCKED IN POSITION REMOVE BOLTS (P513) FROM POSITIONS A & B AND SCREW INTO TAPPED HOLES C & D TO BREAK FRONT TAPER

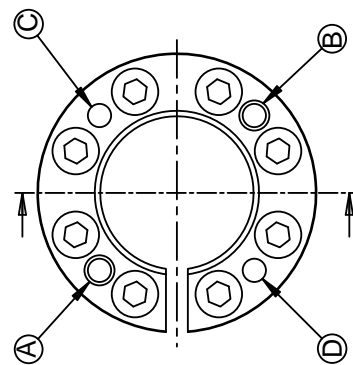
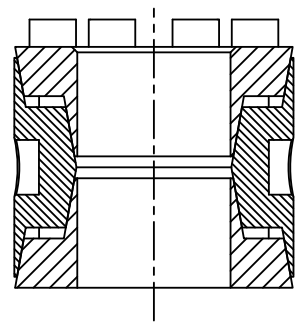
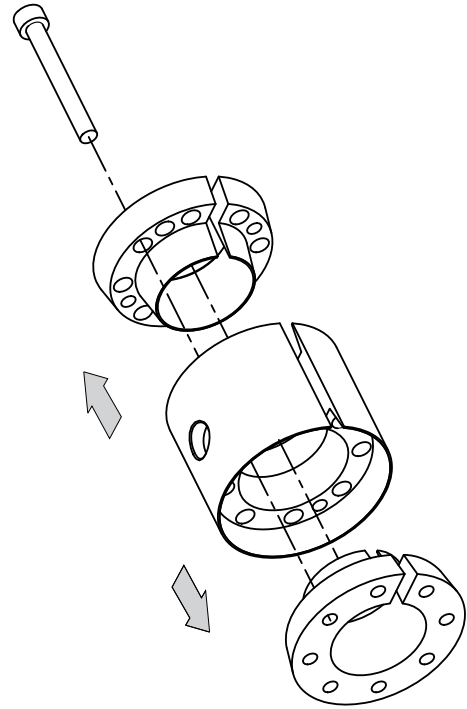

# Dismantling & Assembly Diagrams

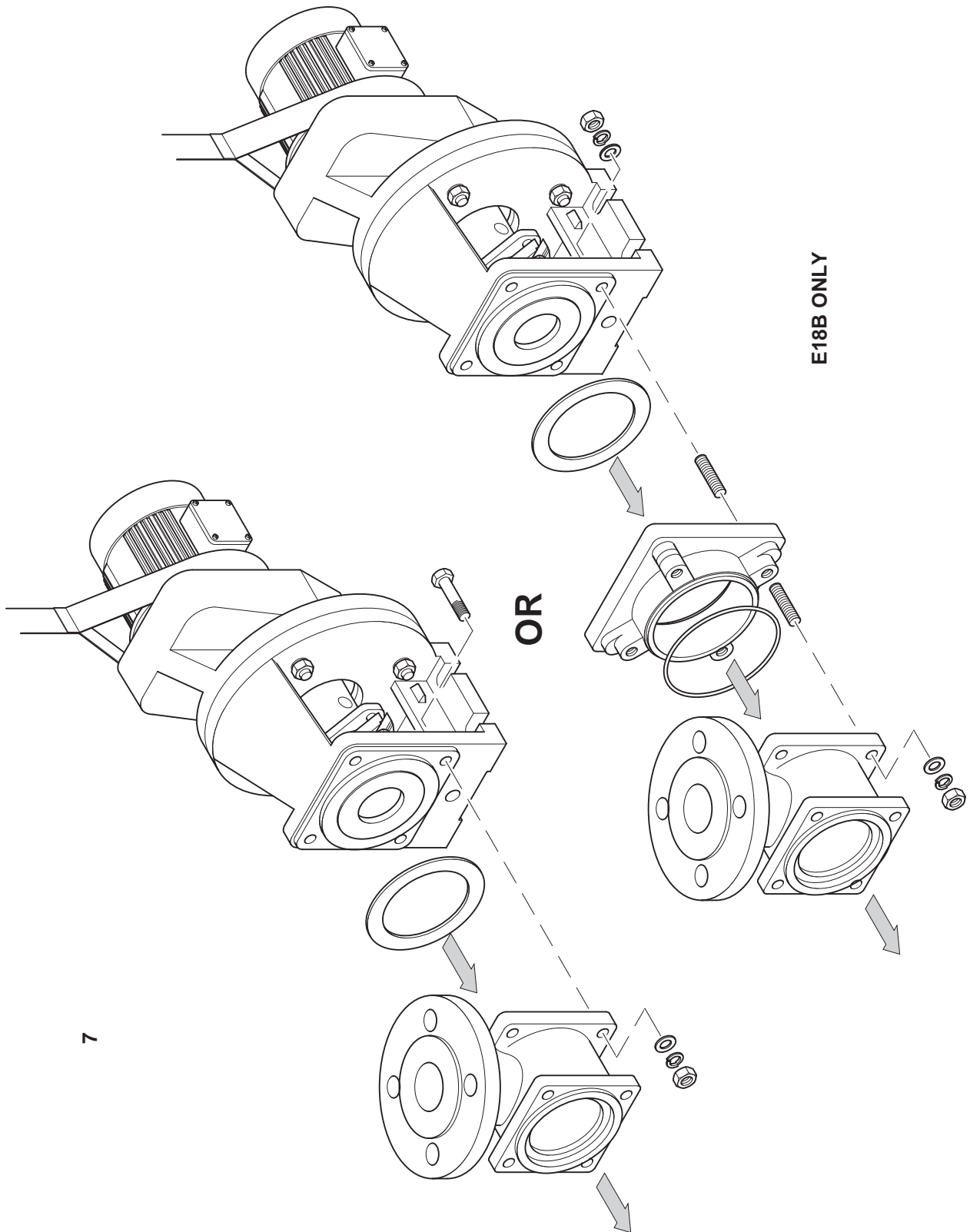

# Dismantling & Assembly Diagrams

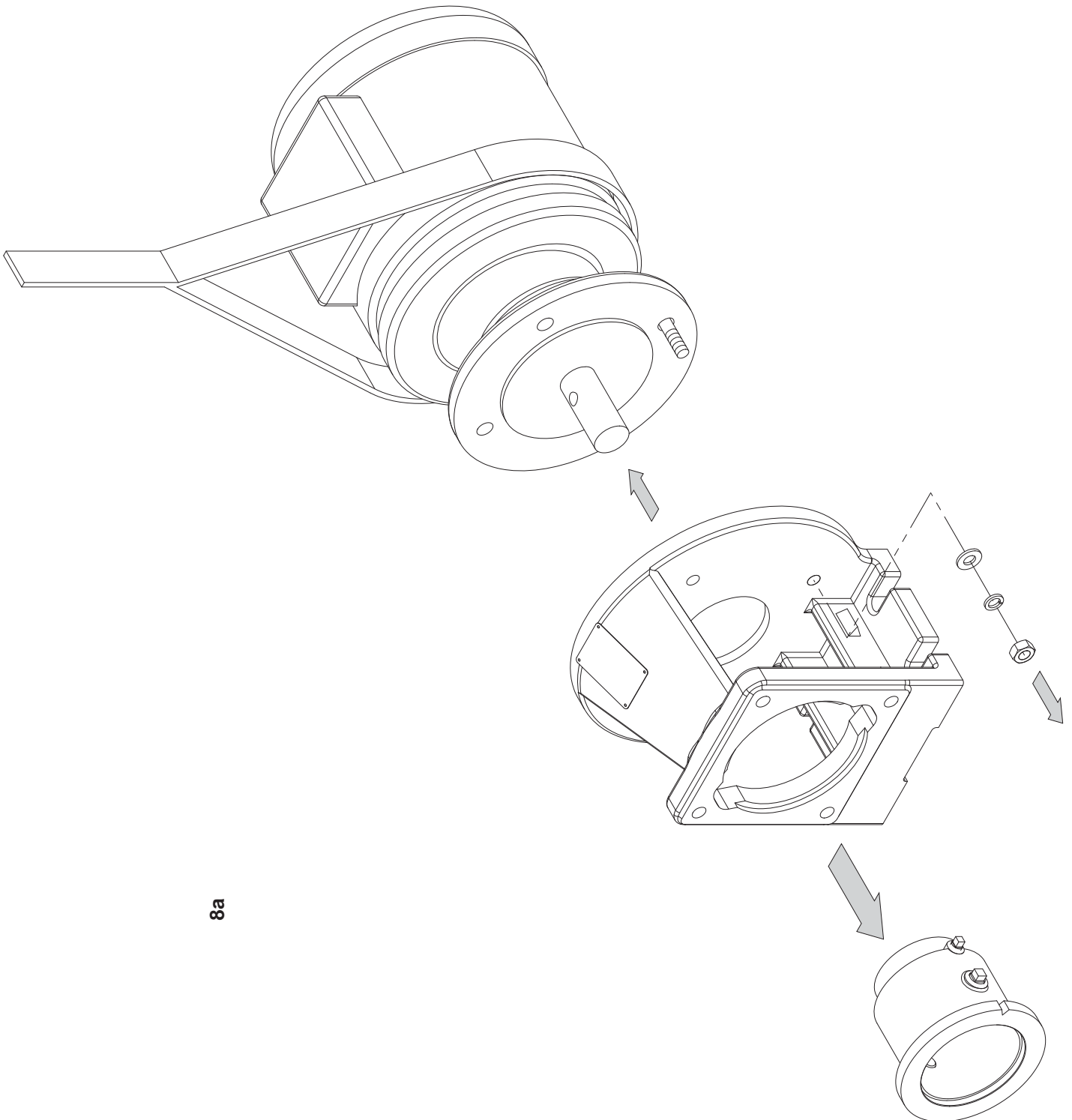

8a

# Dismantling & Assembly Diagrams

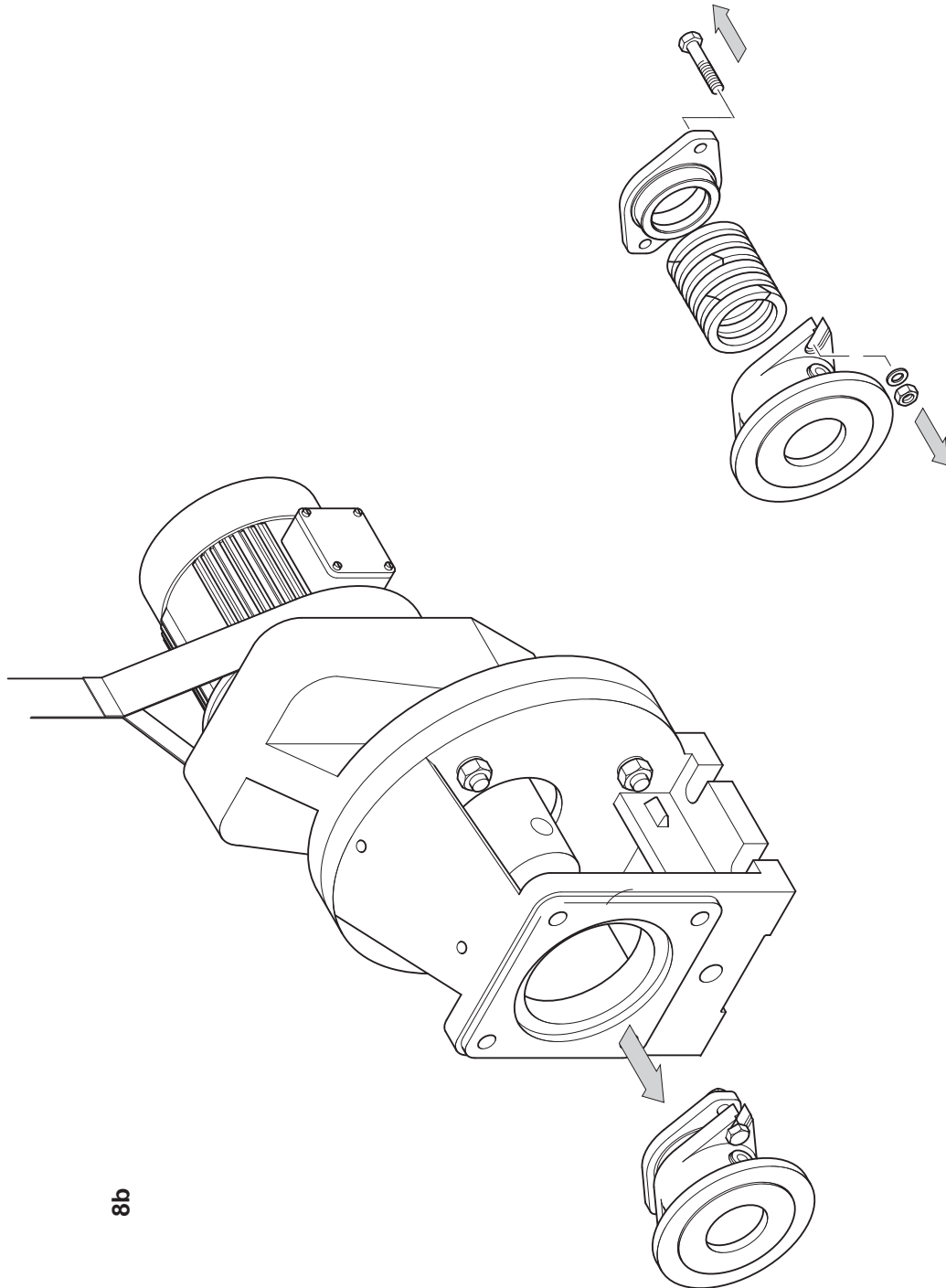

8b

ONLY APPLICABLE IF USING PACKED GLAND PUMP

# Dismantling & Assembly Diagrams

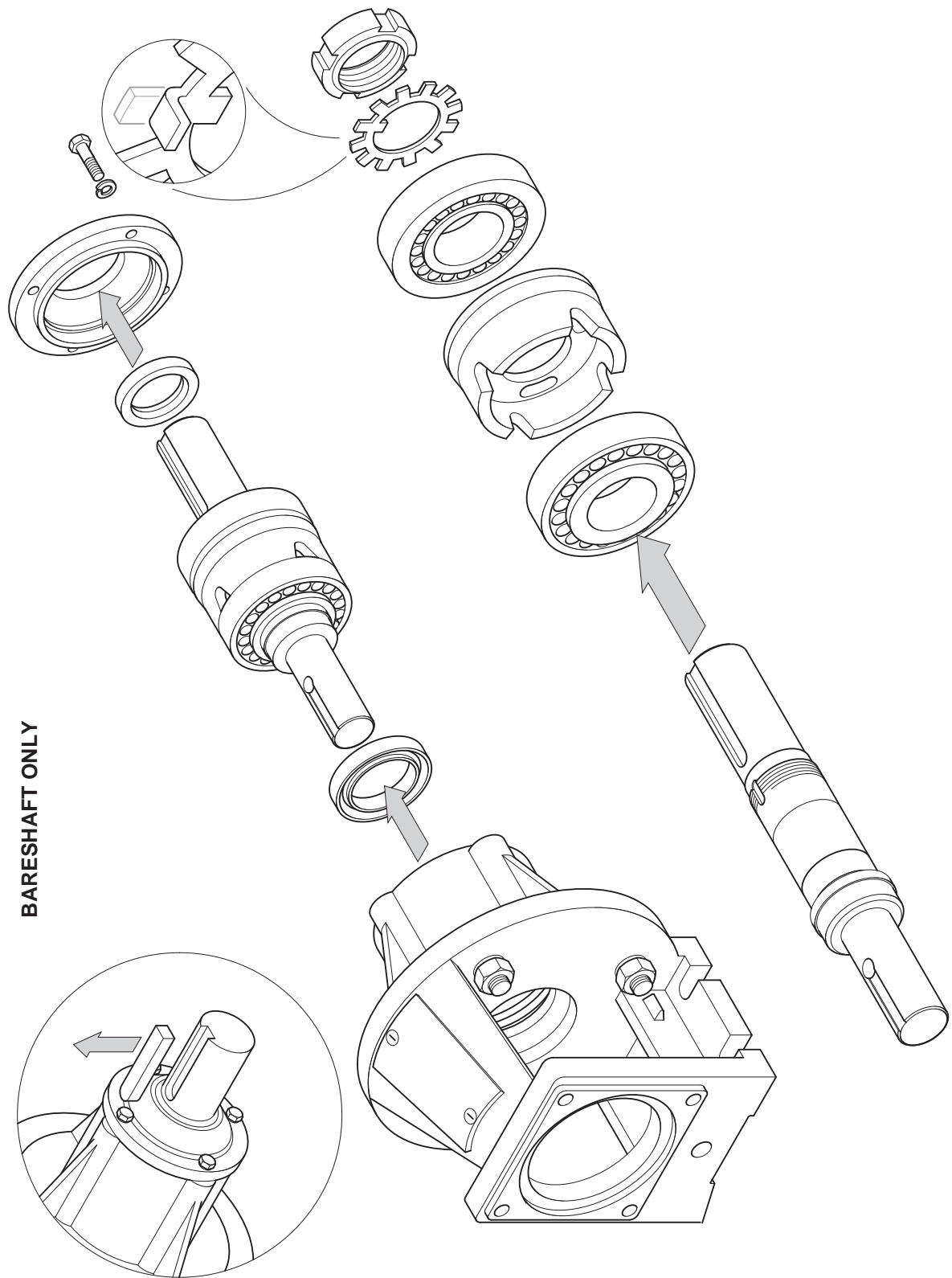

BARESHAFT ONLY

# Dismantling & Assembly Diagrams

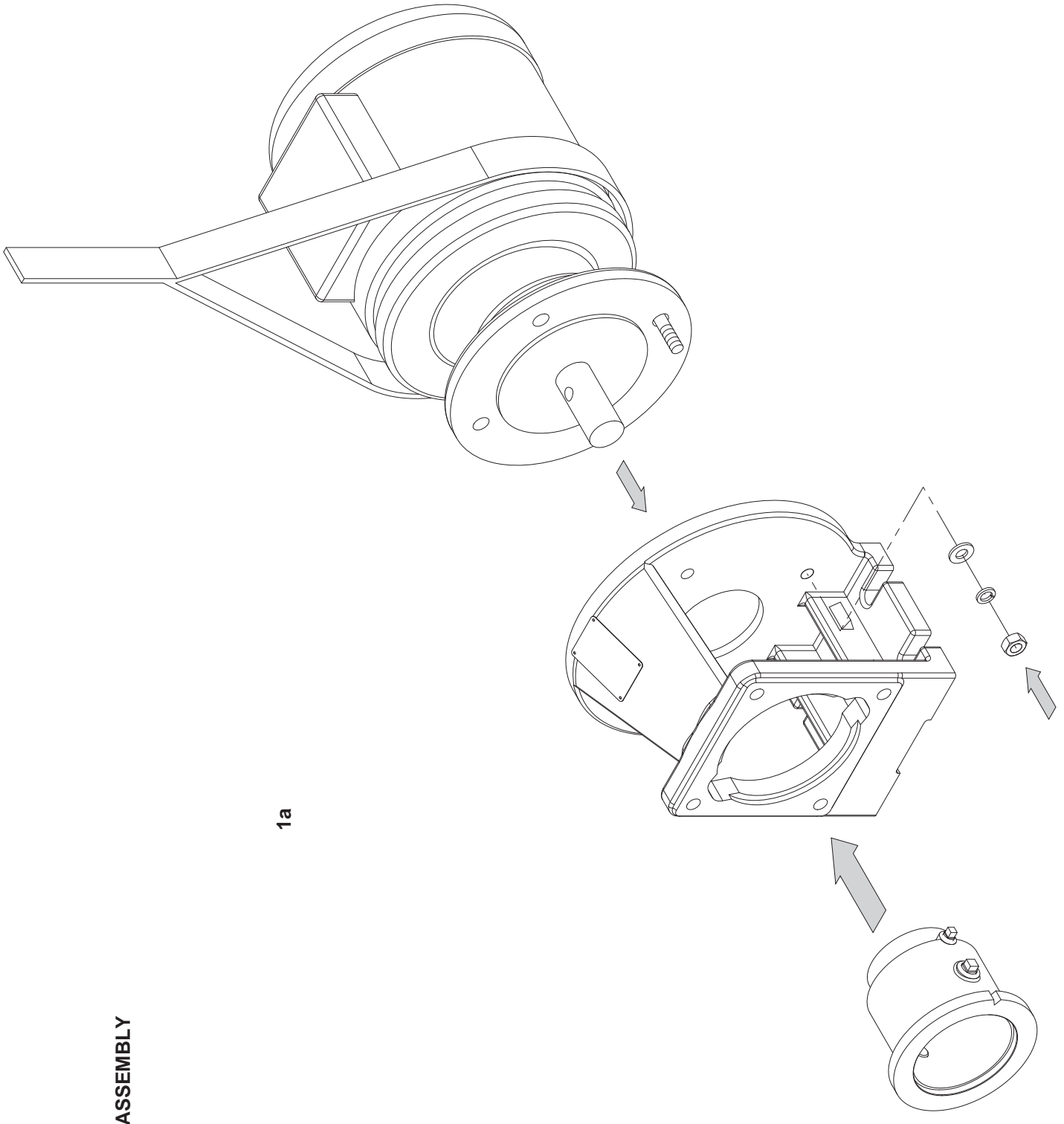

1a

ASSEMBLY

# Dismantling & Assembly Diagrams

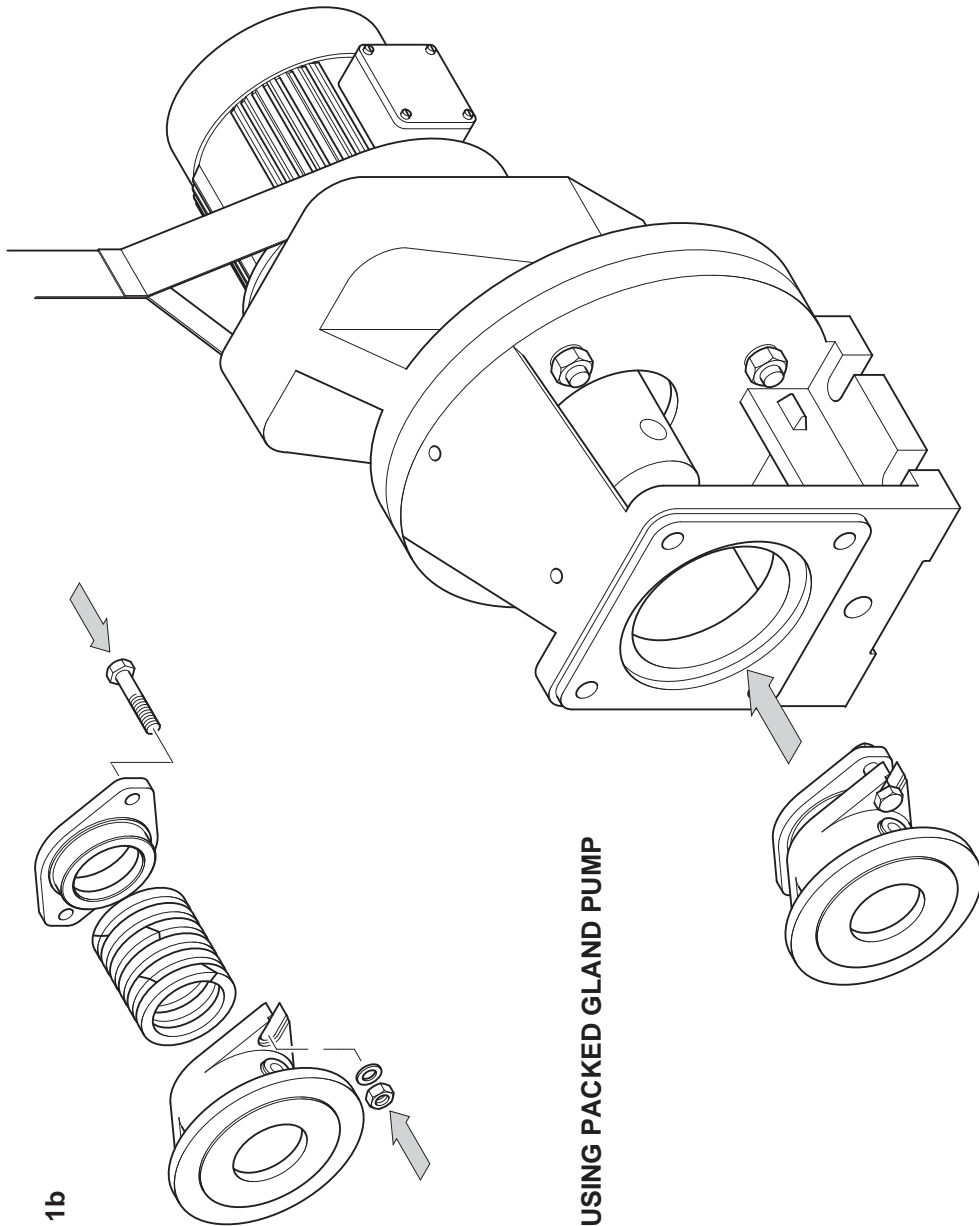

ONLY APPLICABLE IF USING PACKED GLAND PUMP

# Dismantling & Assembly Diagrams

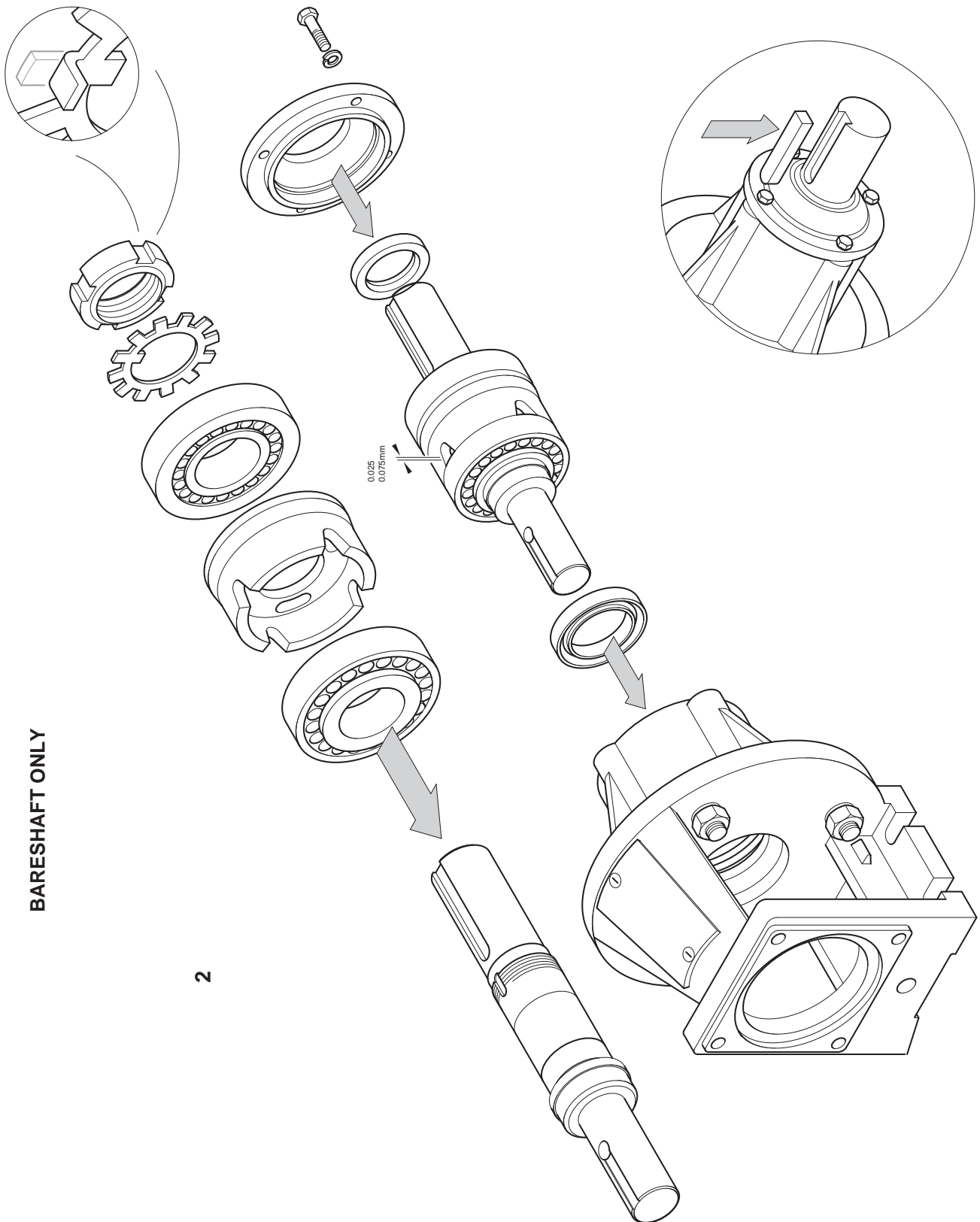

# Dismantling & Assembly Diagrams

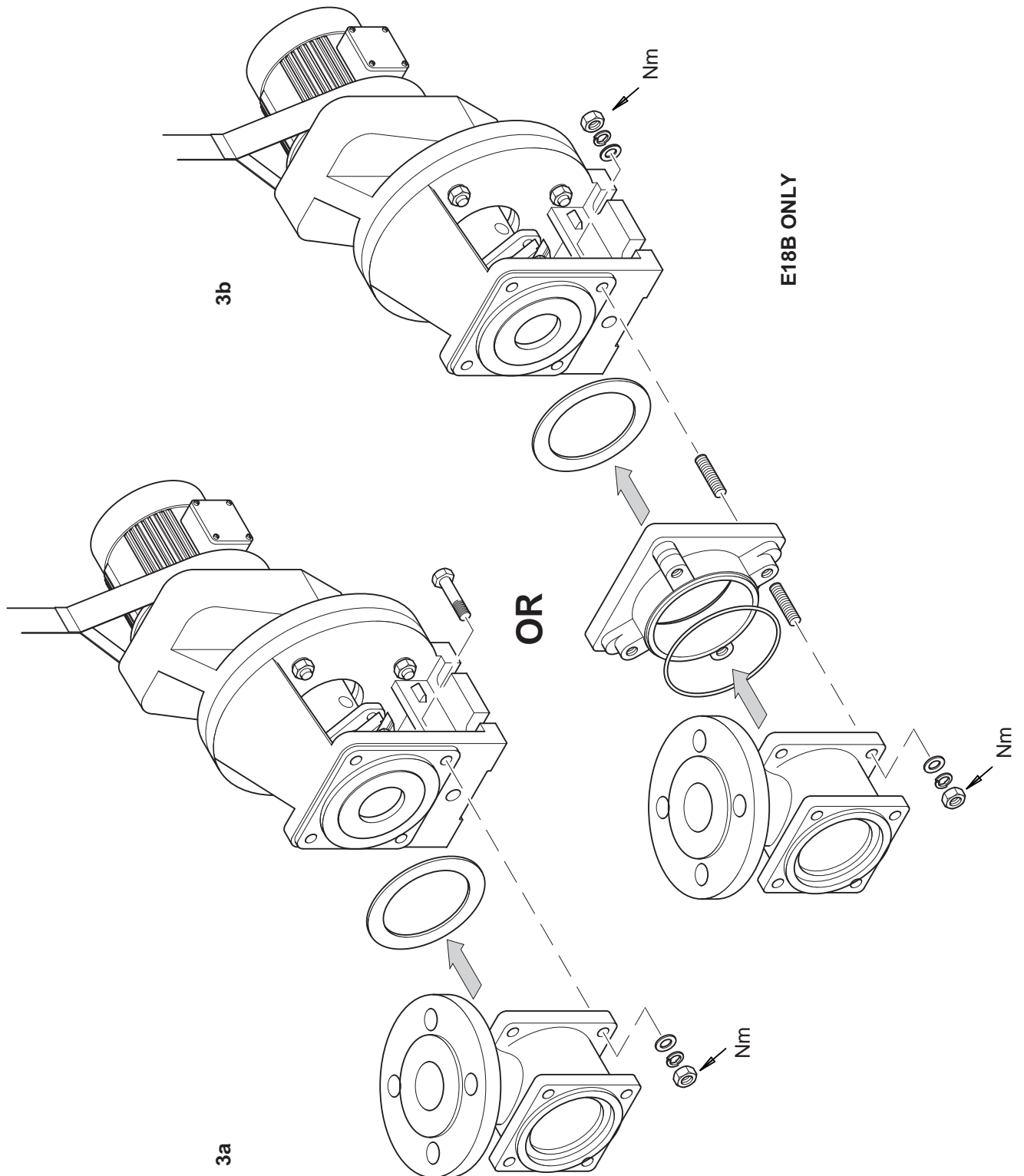

# Dismantling & Assembly Diagrams

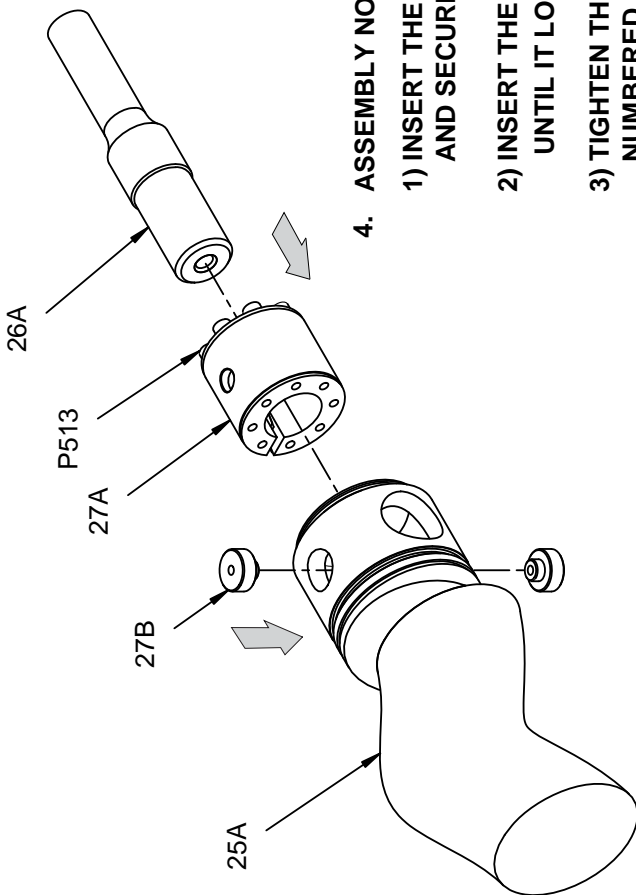

## 4. ASSEMBLY NOTES

- 1) INSERT THE DRIVE CLAMP (27A) INTO THE ROTOR HEAD (25A) AND SECURE IN PLACE WITH THE DRIVE CLAMP PINS (27B)
- 2) INSERT THE FLEXSHAFT (26A) INTO THE DRIVE CLAMP (27A) UNTIL IT LOCATES ON THE CHAMFER
- 3) TIGHTEN THE DRIVE CLAMP BOLTS (P513) GRADUALLY IN THE NUMBERED SEQUENCE (SEE BOTTOM LEFT VIEW) UNTIL THE SPECIFIED TORQUE IS REACHED

CLEARANCE HOLE TO BE IN LINE WITH TAPPED HOLE IN CENTRE TAPER RING

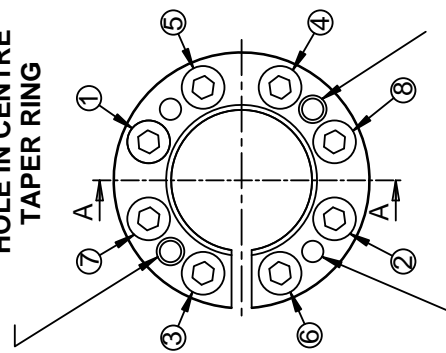

TAPPED HOLE TO BE LINED UP SO IT IS BLIND ON THE CENTRE TAPER RING

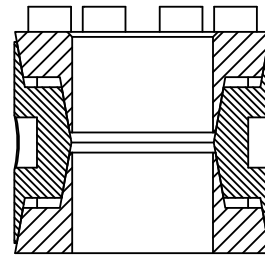

COUNTERBORE IN CENTRE TAPER RING TO BE AT THE FRONT

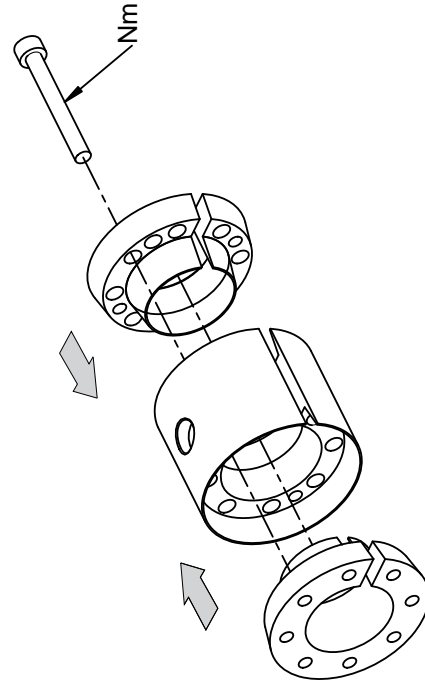

# Dismantling & Assembly Diagrams

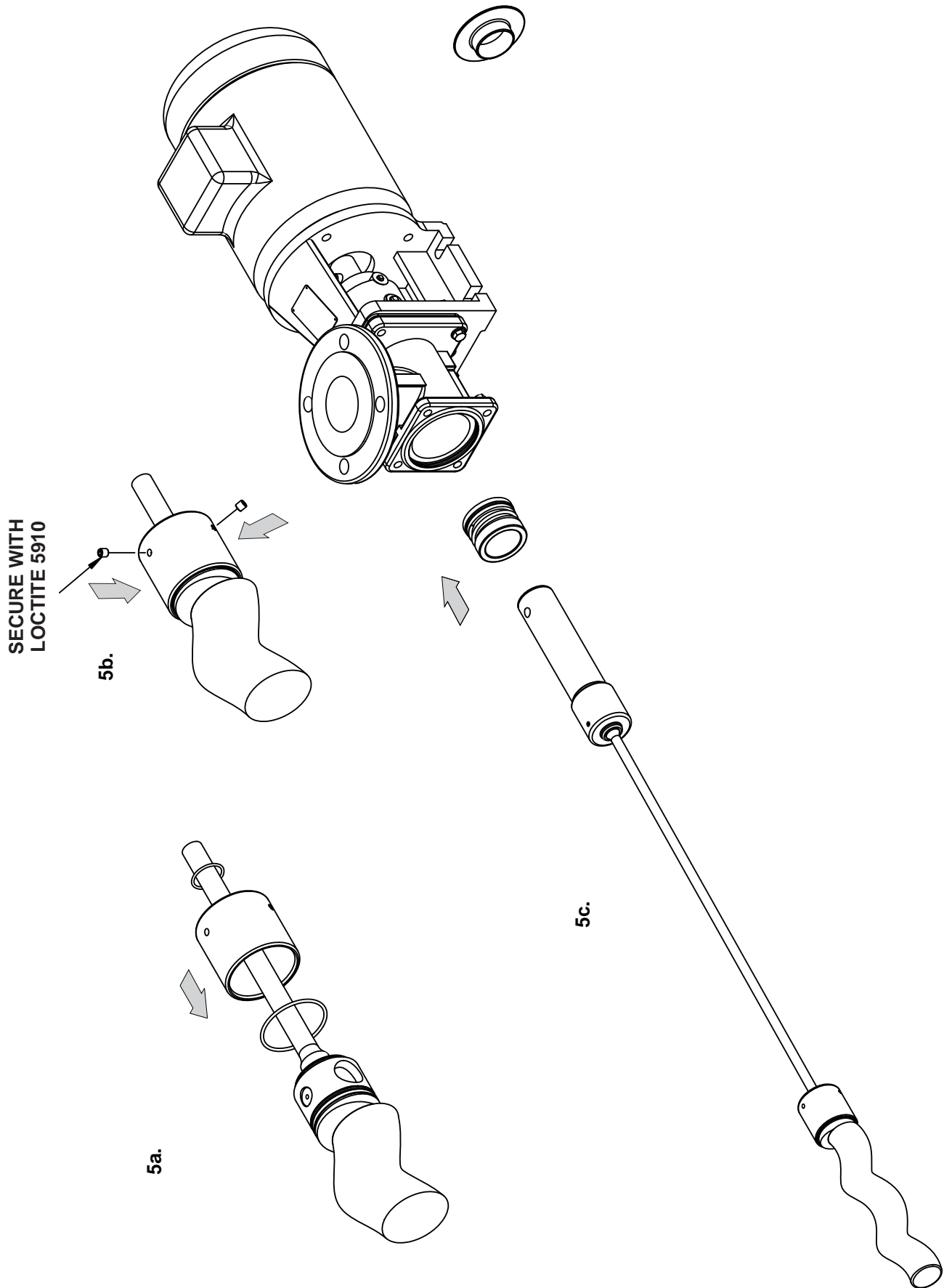

# Dismantling & Assembly Diagrams

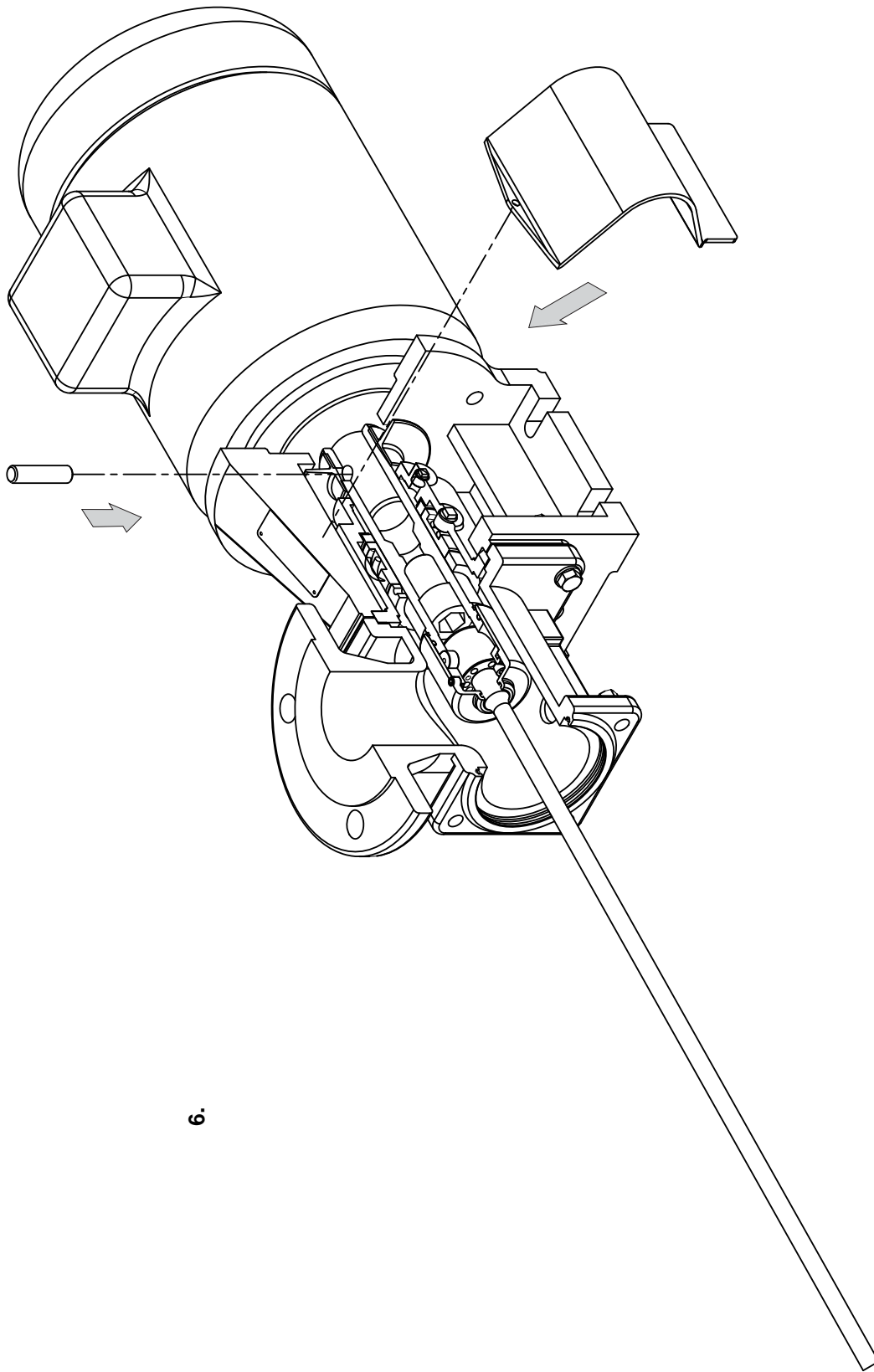

6.

# Dismantling & Assembly Diagrams

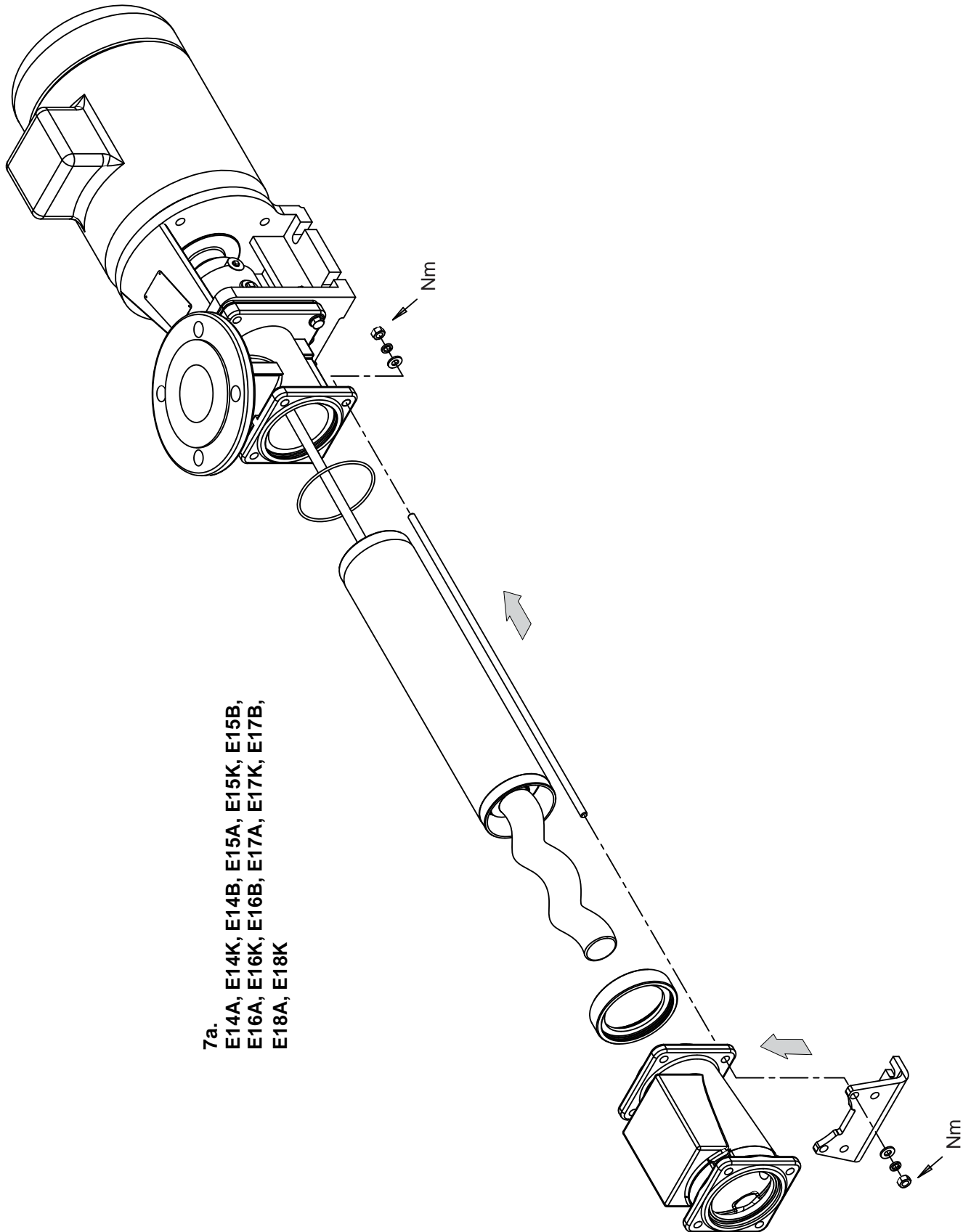

7a.  
E14A, E14K, E14B, E15A, E15K, E15B,  
E16A, E16K, E16B, E17A, E17K, E17B,  
E18A, E18K

# Dismantling & Assembly Diagrams

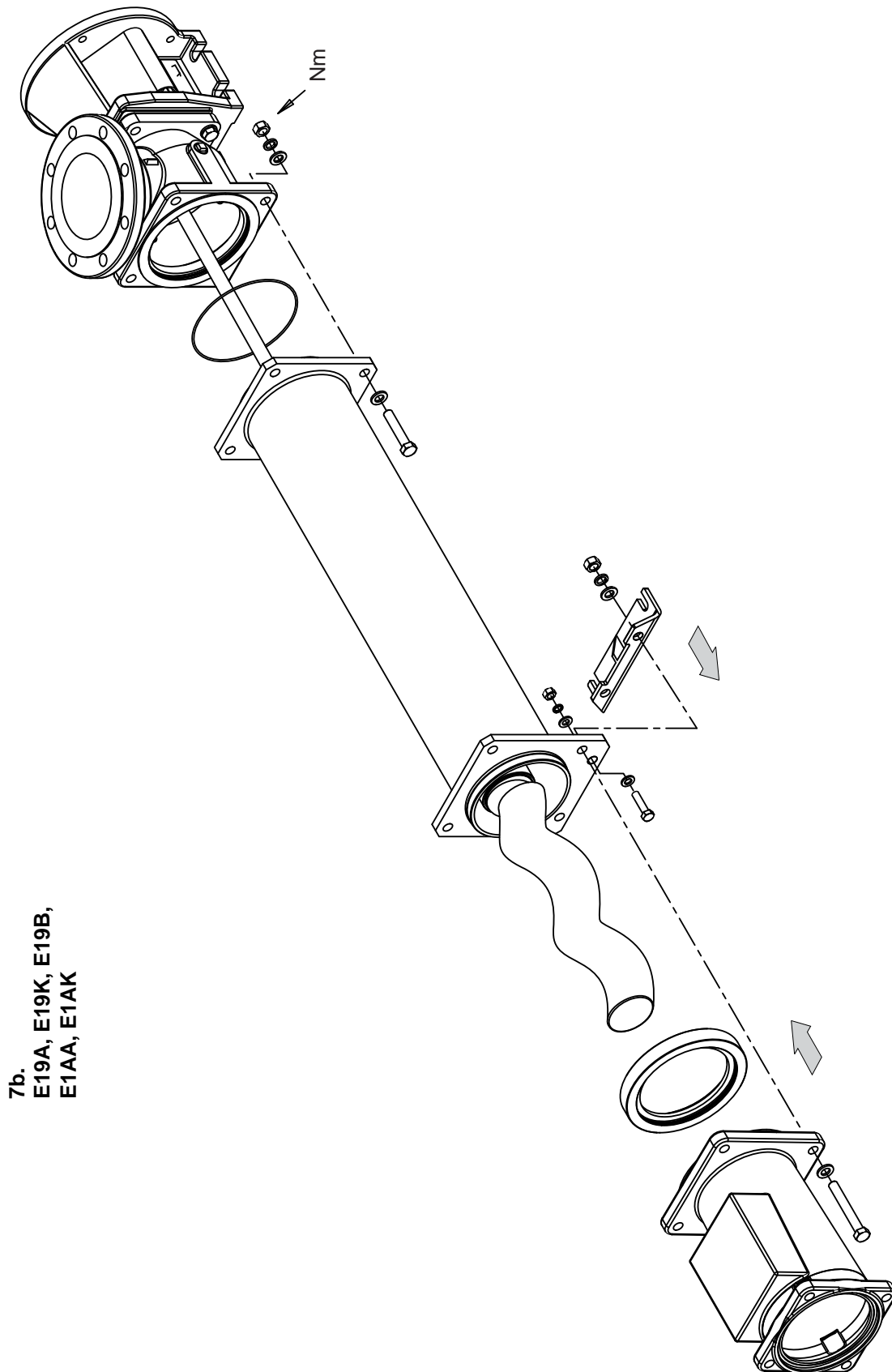

# Dismantling & Assembly Diagrams

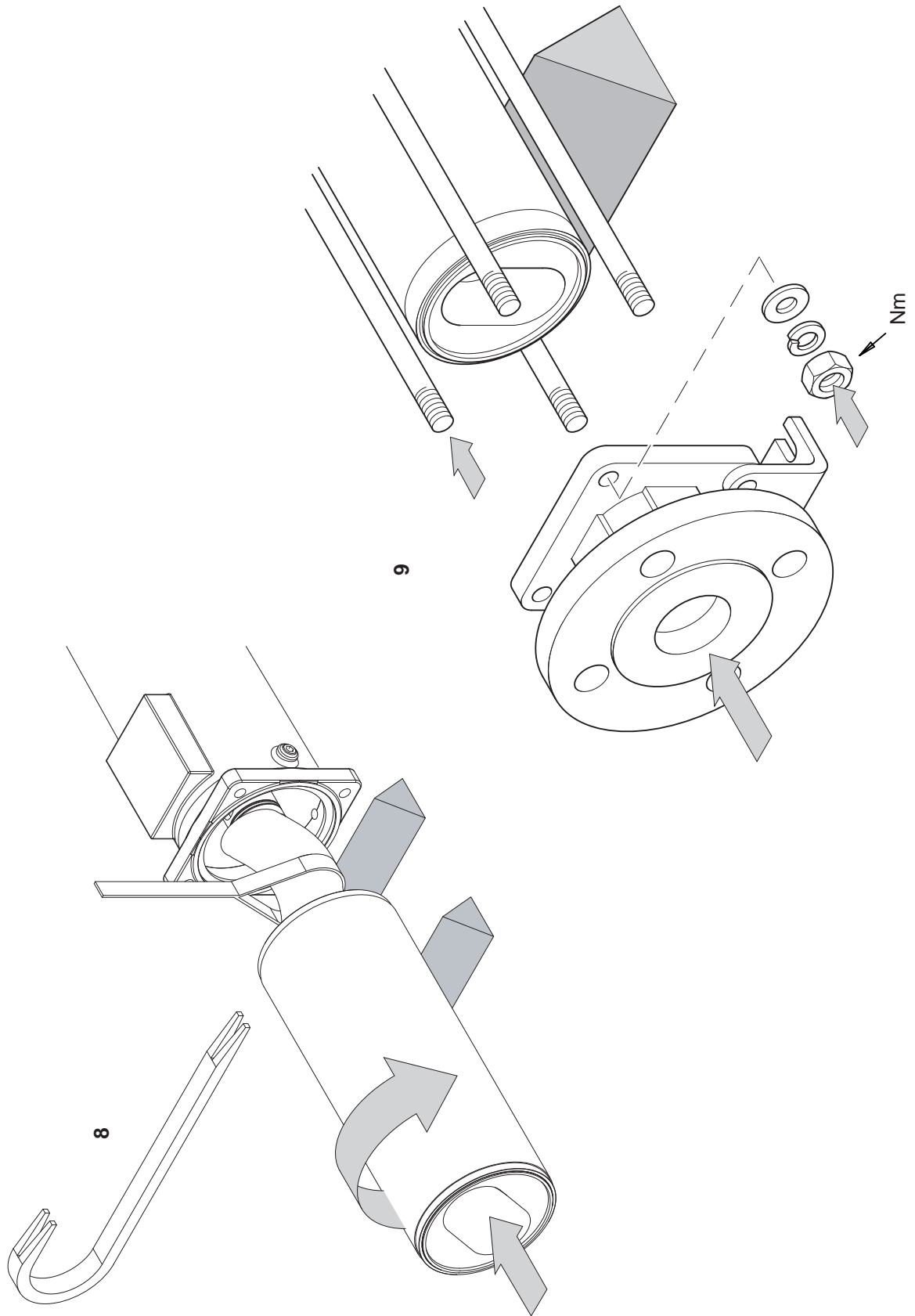

# Setting Length - Mechanical Seal

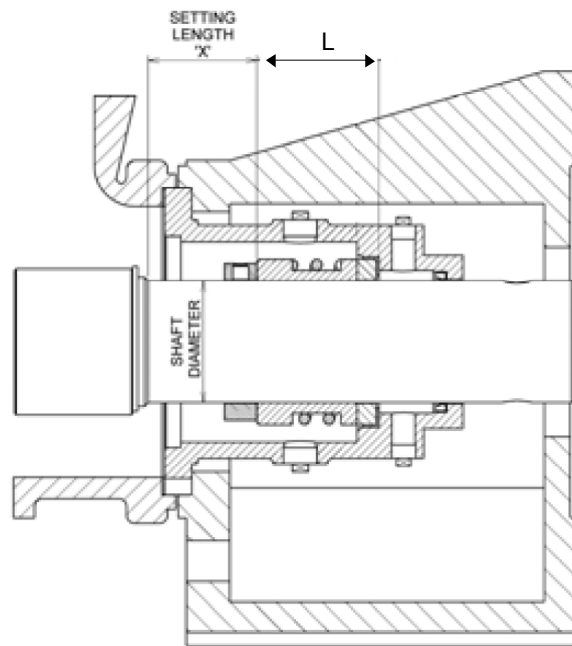

Pump Size	Drive Type	Shaft Diameter mm	Seal Part No.	Seal Working Length L mm	Setting Distance 'X' mm
E14A E14B E14K E15A E15K	Flexishaft	45	M045139G	45.0	41
E15B E16A E16K	Flexishaft	55	M055139G	47.5	34.5
E16B E17A E17B E17K E18A E18K	Flexishaft	65	M065139G	52.5	33.5

**NOTE:** All seal working lengths are to DIN L1K dimensions.  
 This table is not to be used for standard or DIN L1N working length seals.  
 All seals use 'M' type seat except for 85mm which uses 'BS' type or 'M' type.  
 This table is not necessarily compatible with any other seal type - check with Mono Pumps Technical Dept.

# Setting Length - Mechanical Seal

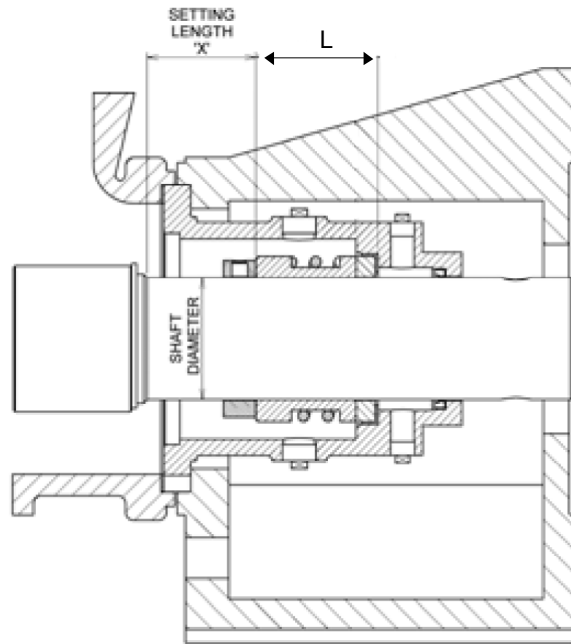

Pump Size	Drive Type	Shaft Diameter mm	Seal Part No.	Seal Working Length L mm	Setting Distance 'X' mm
E18B E19A E19B E19K E1AA E1AK	Flexishaft	85	M085139G	60.0	33
E1AB E1BA E1BK	Flexishaft	85	M085139G	60.0	58

**NOTE:** All seal working lengths are to DIN L1K dimensions.

This table is not to be used for standard or DIN L1N working length seals.

All seals use 'M' type seat except for 85mm which uses 'BS' type or 'M' type.

This table is not necessarily compatible with any other seal type - check with Mono Pumps Technical Dept.

# Exploded Views

BEARING HOUSING ONLY

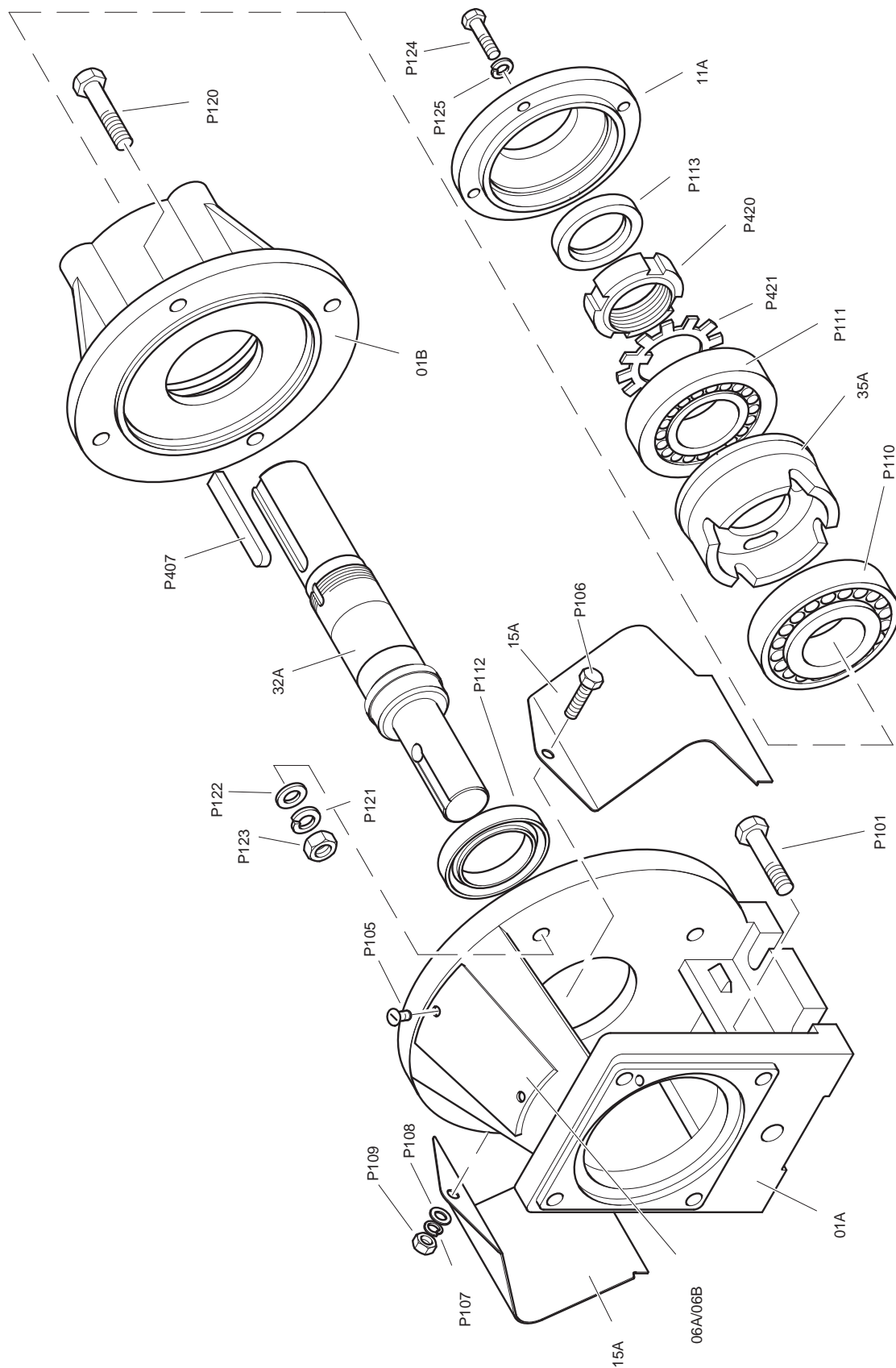

# Exploded Views

**EPSILON RANGE  
CAST IRON PUMPS  
E14A, E14K, E14B, E15A, E15K,  
E15B, E16A, E16K, E16B, E17A,  
E17K, E17B, E18A, E18K**

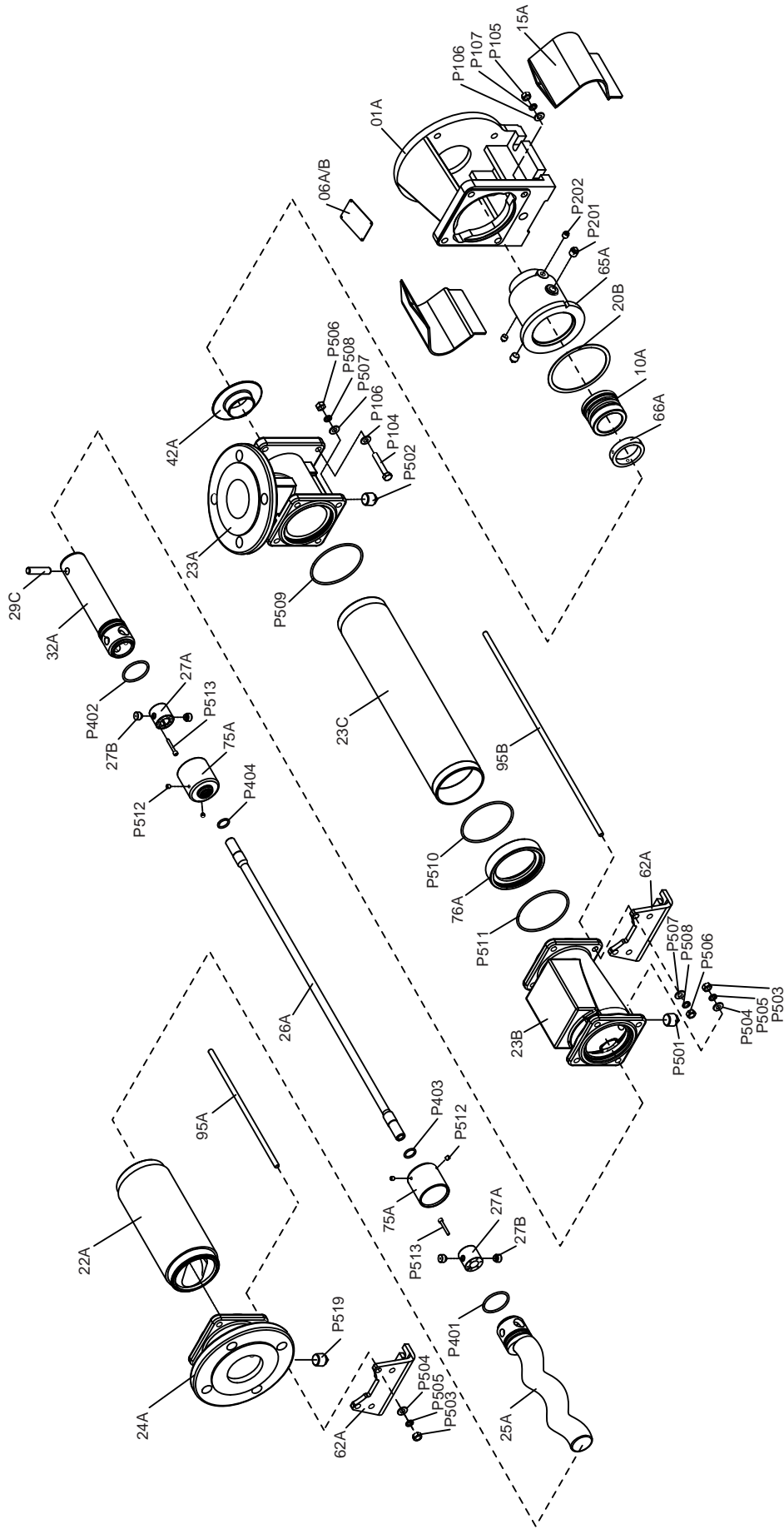









# Exploded Views

**EPSILON RANGE  
STAINLESS STEEL PUMPS  
E17A, E17K, E17B, E18A, E18K,  
E19A, E19K, E19B, E1AA, E1AK**

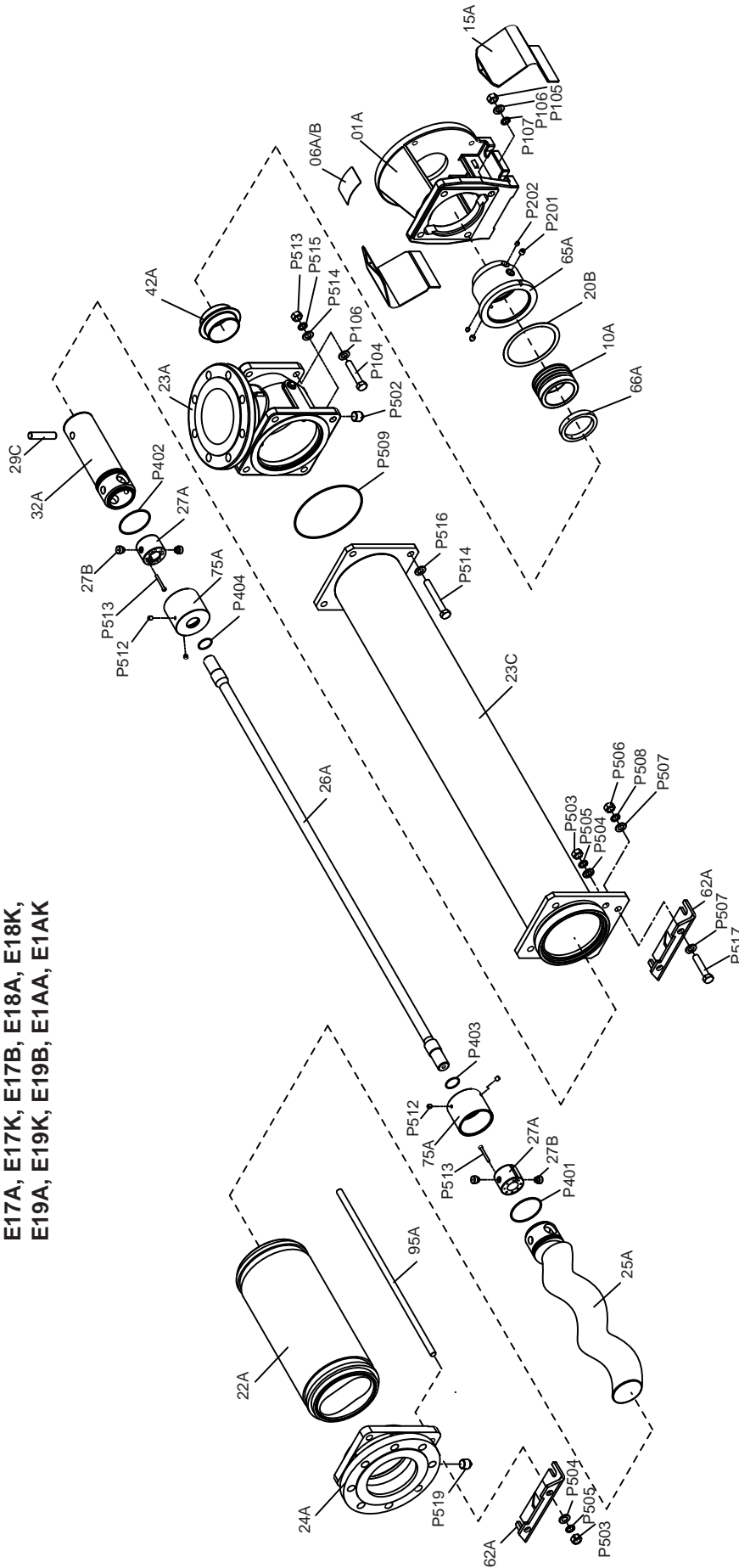

# Exploded Views

## EPSILON RANGE E1AB, E1BA, E1BK

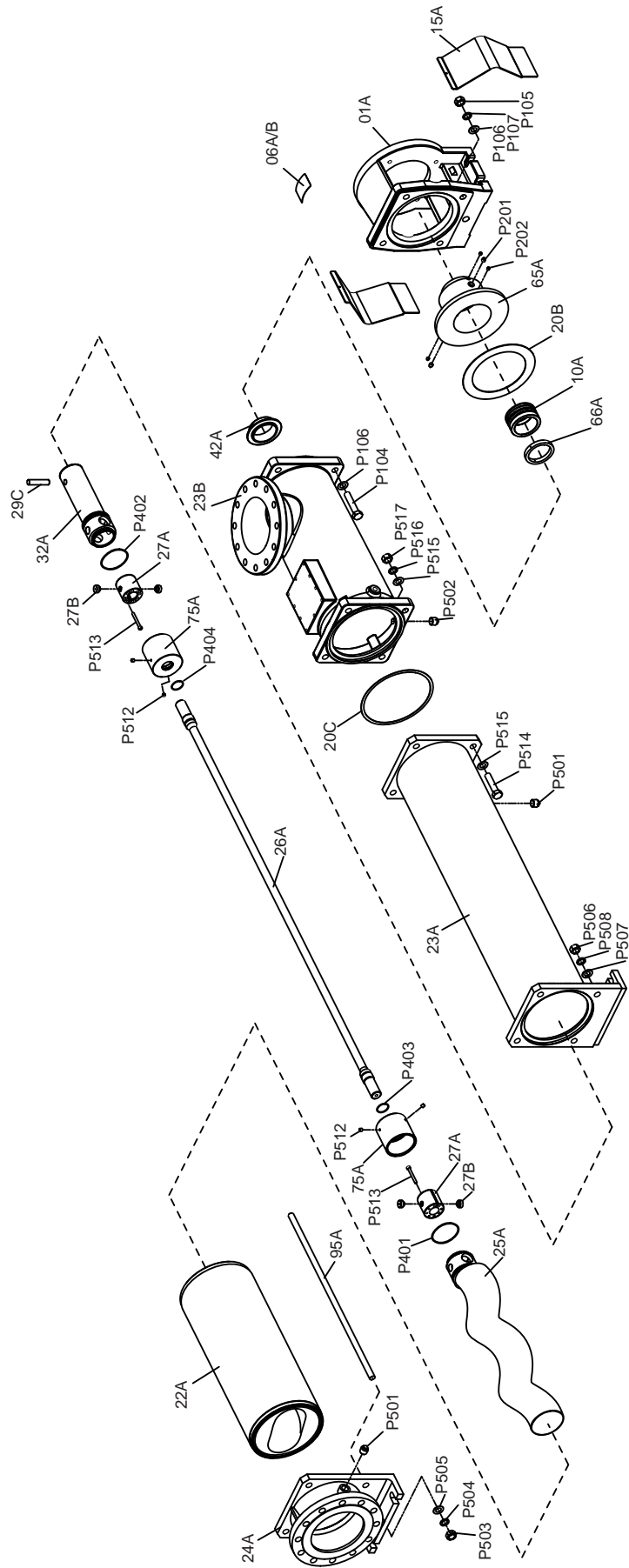

# Torque Tightening Figures

PUMP SIZE	BODY/SUCT. CHAMBER			STATOR TIE BARS		DRIVE CLAMP BOLTS
	P526	Nm P105	P530	Nm P506 P503	Nm P513	
E14A		11		11	5	
E14K		11		11	5	
E14B		11		11	5	
E15A		11		11	5	
E15K		21		11	5	
E15B		21		11	10	
E16A		21		24	10	
E16K		21		24	10	
E16B		36		24	10	
E17A		36		24	10	
E17K		36		24	10	
E17B		36		24	10	
E18A		36		40	10	
E18K		36		40	10	
E18B	50	-	36	40	17	
E19A		90		75	17	
E19K		90		75	17	
E19B		90		75	17	
E1AA		90		75	17	
E1AK		90		75	17	
E1AB		90		75	41	
E1BA		176		120	41	
E1BK		176		120	41	

**Note: Torque tolerances are +/-5% of stated nominal figures.**



---

Member of AxFlow Group

1300 4 BBENG  
[www.brownbros.com.au](http://www.brownbros.com.au)



---

Member of AxFlow Group

0508 4 BBENG  
[www.brownbros.co.nz](http://www.brownbros.co.nz)

**Mono<sup>®</sup> NOV**

One Company, Unlimited Solutions