

ITEM	DESCRIPTION	QTY
1	POWER END ASSEMBLY:	1
2	FLUID CYLINDER:	1
3	SPRING AND DISC ASSEMBLY:	4
4	SEAT:	4
5	VALVE CAGE:	4
6	CYLINDER:	2
7	PISTON CUP;	2
8	PISTON HOLDER: A04	2
9	UMBRELLA: F/E04	2
10	WASHER: UMBRELLA	2
11	CUP WASHER: A04	2
12	VALVE COVER:	2
13	VALVE COVER CLAMP:	1
14	O-RING: UNIFORM #015	2
15	O-RING: UNIFORM #033	2
16	O-RING: UNIFORM #213	6
17	GASKET: VALVE COVER	2
18	RING SEAL: CYLINDER	2
19	CAP SCREW: HEX HEAD, 5/16 X 1.50 LG	2
20	CAP SCREW: HEX HEAD, 3/8 X 5.00 LG	3
21	CAP SCREW: HEX HEAD, 1/2 X 1.50 LG	1
22	NAMEPLATE:	1
23	SELF TAPPING SCREW:	2

**Brown Brothers
Engineers Ltd**
Member of AxFlow Group
0508 4 BBENG
www.brownbros.co.nz

PRIVATE AND CONFIDENTIAL
UNLESS OTHERWISE AGREED TO IN WRITING, THIS DOCUMENT AND ALL THE INFORMATION CONTAINED HEREIN ARE THE CONFIDENTIAL AND EXCLUSIVE PROPERTY OF FMC TECHNOLOGIES AND MAY NOT BE REPRODUCED, USED, DISCLOSED, OR MADE PUBLIC IN ANY MANNER PRIOR TO EXPRESS WRITTEN AUTHORIZATION BY FMC TECHNOLOGIES. THIS DOCUMENT IS ACCEPTED PURSUANT TO AGREEMENT TO THE FOREGOING, AND MUST BE RETURNED UPON DEMAND.

UNLESS OTHERWISE SPECIFIED
DO NOT SCALE THIS DRAWING
ALL DIMENSIONS ARE IN INCHES (MILLIMETERS)
BREAK SHARP EDGES .015 (0.381) MAXIMUM
INSIDE CORNER RADII .030 (0.762) MAXIMUM
ALL SURFACE TEXTURES Ra 250 MICROINCHES (6.3 MICROMETERS)
ALL COAXIAL DIA'S .010 TIR TO SINGLE AXIS
DIM AND TOL PER ASME Y14.5-2009

TOLERANCE
.X .XX .XXX
+ .030 (0.762)
+ .015 (0.381)
+ .005 (0.127)
0° 30'

DESCRIPTION: PUMP ASSEMBLY: A0410 RH, W/1 NPT X 1/2 NPT FLUID END, PISTON CUP, DISC VALVE ASSEMBLIES, HYD DRIVE

DRAWN BY: WOLVERTON, JARROD
DRAFTING CHECK: WOLVERTON, JARROD
DESIGN REVIEW: GILL, CODY
MANUFACTURING APPROVAL: [Signature]
APPROVED BY: KOWALSKI, CHRISTOPHER

DATE: 21-MAR-2016
DATE: 21-MAR-2016
DATE: 10-NOV-2016
DATE: 10-NOV-2016

SHEET SIZE: D
EEN NUMBER: 5039707
DRAWING NUMBER: DUS00000669
SHEET: 1/2

FMC Technologies

1 2 3 4 5 6 7 8 9 10 11 12

A

B

C

D

E

F

G

H

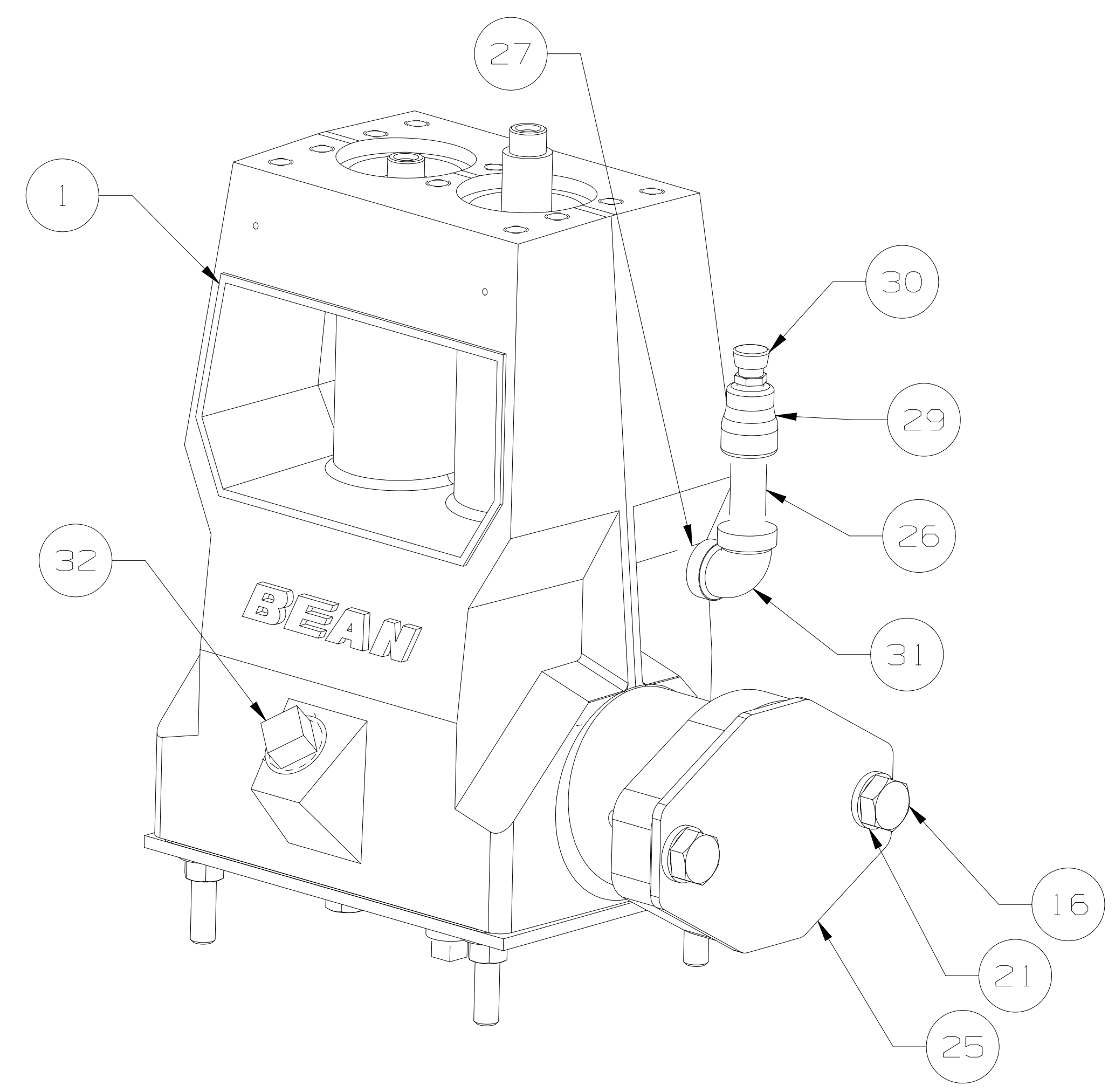
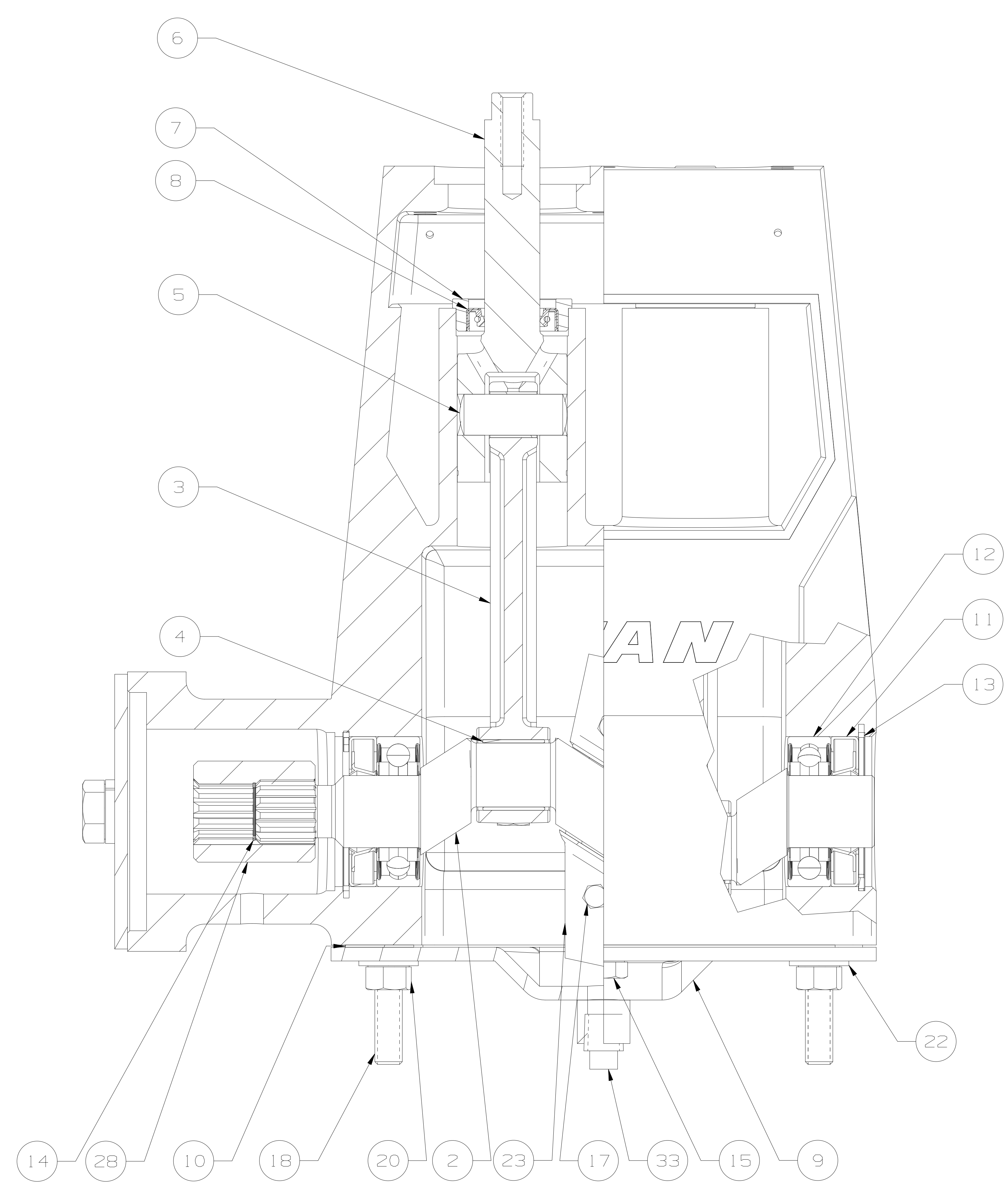

ITEM	DESCRIPTION	QTY
1	POWER FRAME:	1
2	CRANK:	1
3	CONNECTING ROD:	2
4	ROD BEARING: HALF SHELL	4
5	WRIST PIN:	2
6	CROSSHEAD:	2
7	SEAL HOLDER:	2
8	SEAL: PONY ROD	2
9	BACK COVER:	1
10	GASKET: BACK COVER	1
11	SHAFT SEAL:	2
12	BALL BEARING:	2
13	RETAINING RING:	2
14	RETAINER RING: WH-75	1
15	CAP SCREW: HEX HEAD, 3/8 X .75 LG	2
16	CAP SCREW: HEX HEAD, 1/2 X 1.00 LG	2
17	CAP SCREW: HEX HD #10 X .75 LG	2
18	STUD: 3/8 X 2.25 LG	4
19	HEX NUT: #10 (NOT SHOWN)	2
20	HEX NUT: 3/8	4
21	LOCK WASHER: REGULAR, 1/2	2
22	FLAT WASHER: TYPE A, 3/8 N	4
23	OIL SLINGER: RH	1
24	BOLTING STRIP: (NOT SHOWN)	1
25	PROTECTIVE COVER:	1
26	NIPPLE: 1/4 S40, 1/4 NPT X 2.00LG	1
27	NIPPLE: 1/4 S40, 1/4 NPT X 1.25LG	1
28	COUPLING:	1
29	REDUCER: 1/4 NPT X 1/8 NPT	1
30	LUBE VENT: 1/8 PTF	1
31	ELBOW: 1/4 FEMALE NPT	1
32	PIPE PLUG: SQ HEAD, 3/4 NPT	1
33	PIPE PLUG: 1/4" NPT	1
34	PIPE PLUG: SQ HEAD, 1/8 NPT (NOT SHOWN)	1

PRIVATE AND CONFIDENTIAL UNLESS OTHERWISE AGREED TO IN WRITING, THIS DOCUMENT AND ALL THE INFORMATION CONTAINED HEREIN ARE THE CONFIDENTIAL AND EXCLUSIVE PROPERTY OF FMC TECHNOLOGIES AND MAY NOT BE REPRODUCED, USED, DISCLOSED, OR MADE PUBLIC IN ANY MANNER WITHOUT THE EXPRESS WRITTEN AUTHORIZATION OF FMC TECHNOLOGIES. THIS DOCUMENT IS ACCEPTED PURSUANT TO AGREEMENT TO THE FOREGOING, AND MUST BE RETURNED UPON DEMAND. MANUFACTURER AGREES THAT ARTICLES MADE IN ACCORDANCE WITH THIS DOCUMENT SHALL BE CONSIDERED FMC TECHNOLOGIES' DESIGN, AND THAT CONFIDENTIAL ARTICLES OR PARTS THEREOF SHALL NOT BE MANUFACTURED FOR THE USE OR SALE BY MANUFACTURER OR ANY OTHER PERSON OR ENTITY WITHOUT PRIOR EXPRESS WRITTEN AUTHORIZATION BY FMC TECHNOLOGIES.	UNLESS OTHERWISE SPECIFIED DO NOT SCALE THIS DRAWING ALL DIMENSIONS ARE IN INCHES (MILLIMETERS) BREAK SHARP EDGES .015 (0.381) MAXIMUM INSIDE CORNER RADI .030 (0.762) MAXIMUM ALL SURFACE TEXTURES Ra 250 MICROINCHES (6.3 MICROMETERS) ALL COAXIAL DIA'S .010 TIR TO SINGLE AXIS DIM AND TOL PER ASME Y14.5-2009	TOLERANCE .X -- + .030 (0.762) .XX -- + .015 (0.381) .XXX -- + .005 (0.127) ANGLE -- + 0° 30'	DESCRIPTION POWER END ASSEMBLY; A04 LH OR RH, SAE A HYDRAULIC DRIVE, 13 TOOTH SPLINE, W/ STUDS	DRAWN BY: WOLVERTON, JARROD	DATE: 09-SEP-2016		
				DRAFTING CHECK: WOLVERTON, JARROD	DATE: 04-OCT-2016		SHEET SIZE D
				DESIGN REVIEW: GILL, CODY	DATE: 20-OCT-2016	LATEST EGN NUMBER 5040913	REV. E
				MANUFACTURING APPROVAL: MCLCLAIN, MATHEW	DATE: 01-NOV-2016	DRAWING NUMBER DUS00000499	SHEET 1/1

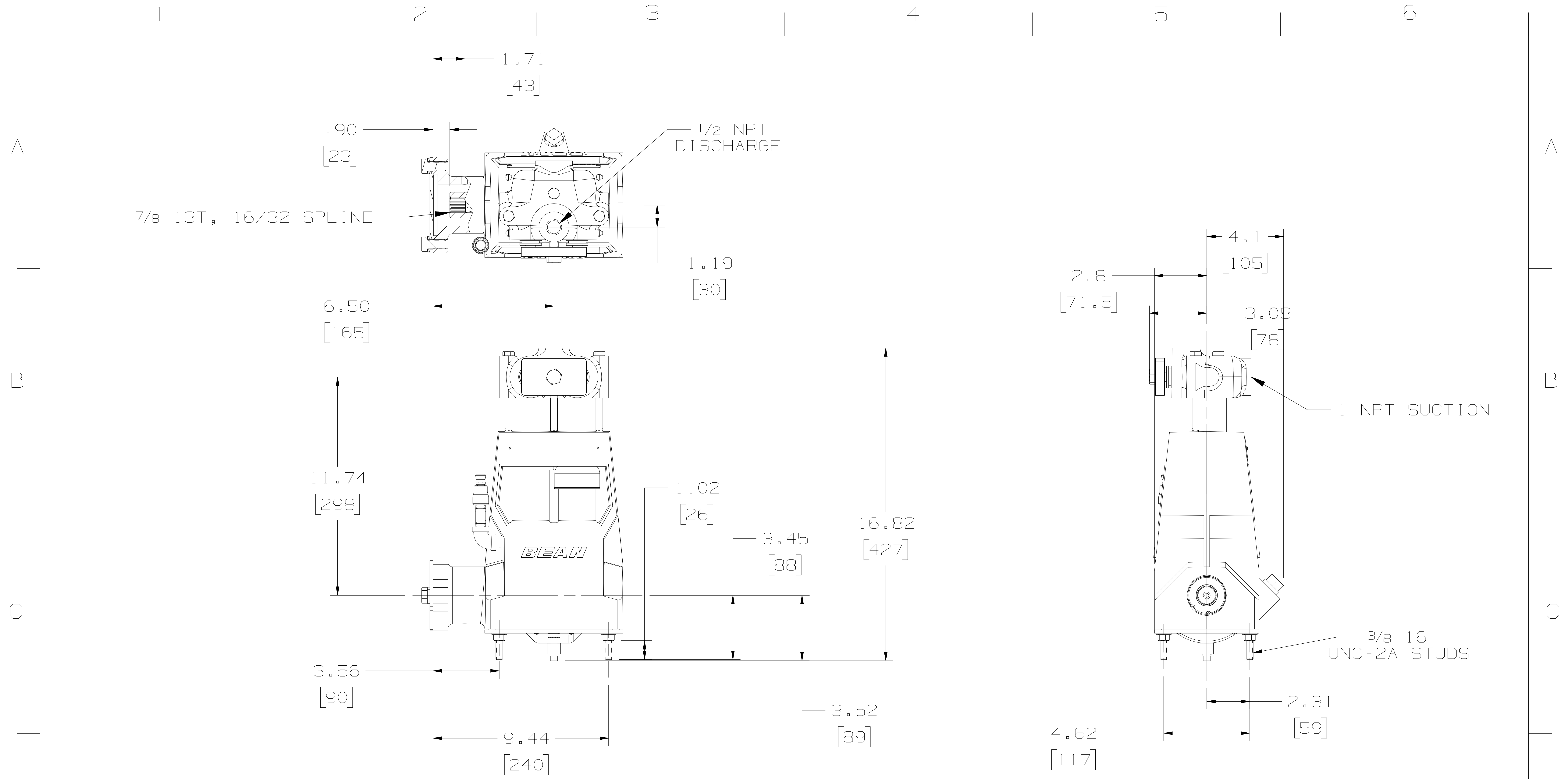

PRIVATE AND CONFIDENTIAL

UNLESS OTHERWISE AGREED TO IN WRITING, THIS DOCUMENT AND ALL THE INFORMATION CONTAINED HEREIN ARE THE CONFIDENTIAL AND EXCLUSIVE PROPERTY OF FMC TECHNOLOGIES AND MAY NOT BE REPRODUCED, USED, DISCLOSED, OR MADE PUBLIC IN ANY MANNER PRIOR TO EXPRESS WRITTEN AUTHORIZATION BY FMC TECHNOLOGIES. THIS DOCUMENT IS ACCEPTED PURSUANT TO AGREEMENT TO THE FOREGOING, AND MUST BE RETURNED UPON DEMAND.

MANUFACTURER AGREES THAT ARTICLES MADE IN ACCORDANCE WITH THIS DOCUMENT SHALL BE CONSIDERED FMC TECHNOLOGIES' DESIGN, AND THAT IDENTICAL ARTICLES OR PARTS THEREOF SHALL NOT BE MANUFACTURED FOR THE USE OR SALE BY MANUFACTURER OR ANY OTHER PERSON OR ENTITY WITHOUT PRIOR EXPRESS WRITTEN AUTHORIZATION BY FMC TECHNOLOGIES.

ENGINEERING DIMENSIONAL OUTLINE

DESCRIPTION
PUMP ASSEMBLY; A0410 RH,
W/1 NPT X 1/2 NPT FLUID
END, PISTON CUP, DISC
VALVE ASSEMBLIES, HYD
DRIVE

DRAWN BY: WOLVERTON, JARROD	DATE: 21-MAR-2016
DRAFTING CHECK: WOLVERTON, JARROD	DATE: 21-MAR-2016
DESIGN REVIEW: GILL, CODY	DATE: 10-NOV-2016
MANUFACTURING APPROVAL:	DATE:
APPROVED BY: KOWALSKI, CHRISTOPHER	DATE: 10-NOV-2016

FMC Technologies	
ECN NUMBER 5039707	REV. B
DRAWING NUMBER DU500000669	SHEET 2/2

COPYRIGHT FMC TECHNOLOGIES