

W+

CENTRIFUGAL PUMP

FORM NO.: 453342-43 USA
REVISION: 07/2018

READ AND UNDERSTAND THIS MANUAL PRIOR TO OPERATING OR SERVICING THIS PRODUCT.





Contents

USA

Introduction.....	4
Warranty	4
Shipping Damage or Loss.....	5
Safety Information	6
Warnings	6
Sectional Drawing	10
1. Introduction to the W+ program.....	11
1.1 The W+ range	11
1.2 W+ pump features.....	11
1.3 Identifying the pump model.....	11
2. Installation of the Pump.....	12
2.1 Positioning.....	12
2.2 Lining up the pipe system	12
2.3 Power supply.....	12
2.4 Water supply for water-flushed shaft seal.....	12
2.5 Connecting steam or steam condensate for aseptic use	12
3. Before Start-up.....	13
3.1 Checking the pump body for foreign material	13
3.2 Testing the pump.....	13
4. Putting the Pump into Service	13
4.1 Flushing water/steam/condensate etc.....	13
5. Maintenance	14
5.1 Checking the shaft seal.....	14
5.2 Replacing the shaft seal.....	14
5.3 Replacement of motor.....	16
5.4 Recommended inventory of spare parts	17
6. Technical data	17
6.1 Maximum permissible outlet pressure	17
6.2 Required torque	18
7. W+ Spare Parts, Dimensions.....	19
7.1 Pump Dimensions	19
7.2 Pump Parts	24
7.3 Impeller.....	26
7.4 Shaft Seal.....	28
7.5 Seal Kit.....	30
7.6 Shaft.....	32
7.7 Motor Adapter and Shaft Guard	33
7.8 Frame	35



Introduction

Congratulations, you are the owner of a quality built item from SPX FLOW. This pump was manufactured by the skilled personnel of a company which has served the needs of the dairy, food and process industries for more than 100 years.

The purpose of this manual is to provide instructions for the safe installation, operation and maintenance of your SPX FLOW equipment. Read and understand the entire manual before removing from the crate and installing the equipment.

SPX FLOW is committed to providing quality equipment and customer satisfaction. We have a unique network of sales and service support throughout the world which are listed in this manual. Please note the office located nearest to you. Should you have any questions concerning any information contained in this manual, contact SPX FLOW in Delavan, WI at 1-800-252-5200 for assistance.

Warranty

LIMITED WARRANTY: Unless otherwise negotiated at the time of sale, SPX FLOW US, LLC (SPX FLOW) goods, auxiliaries and parts thereof are warranted to the original purchaser against defective workmanship and material for a period of twelve (12) months from date of installation or eighteen (18) months from date of shipment from factory, whichever expires first. If the goods or services do not conform to the warranty stated above, then as Buyer's sole remedy, SPX FLOW shall, at SPX FLOW's option, either repair or replace the defective goods or re-perform defective services. Third party goods furnished by SPX FLOW will be repaired or replaced as Buyer's sole remedy, but only to the extent provided in and honored by the original manufacturer's warranty. Unless otherwise agreed to in writing, SPX FLOW shall not be liable for breach of warranty or otherwise in any manner whatsoever for: (i) normal wear and tear; (ii) corrosion, abrasion or erosion; (iii) any good or services which, following delivery or performance by SPX FLOW, has been subjected to accident, abuse, misapplication, improper repair, alteration, improper installation or maintenance, neglect, or excessive operating conditions; (iv) defects resulting from Buyer's specifications or designs or those of Buyer's contractors or subcontractors other than SPX FLOW; or (v) defects resulting from the manufacture, distribution, promotion or sale of Buyer's products.

THE WARRANTIES CONTAINED HEREIN ARE THE SOLE AND EXCLUSIVE WARRANTIES AVAILABLE TO BUYER AND SPX FLOW HEREBY DISCLAIMS ANY OTHER WARRANTIES, EXPRESS OR IMPLIED, INCLUDING WITHOUT LIMITATION THE IMPLIED WARRANTIES OF MERCHANTABILITY AND FITNESS FOR A PARTICULAR PURPOSE. THE FOREGOING REPAIR, REPLACEMENT AND RE-PERFORMANCE OBLIGATIONS STATE SPX FLOW'S ENTIRE AND EXCLUSIVE LIABILITY AND BUYER'S EXCLUSIVE REMEDY FOR ANY CLAIM IN CONNECTION WITH THE SALE AND FURNISHING OF SERVICES, GOODS OR PARTS, THEIR DESIGN, SUITABILITY FOR USE, INSTALLATION OR OPERATIONS.

Introduction

Shipping Damage or Loss

If equipment is damaged or lost in transit, file a claim at once with the delivering carrier. The carrier has a signed Bill of Lading acknowledging that the shipment has been received from SPX FLOW in good condition. SPX FLOW is not responsible for the collection of claims or replacement of materials due to transit shortage or damages.

Warranty Claim

Warranty claims must have a **Returned Material Authorization (RMA)** from the Seller or returns will not be accepted. Contact 800-252-5200 or 262-728-1900. Claims for shortages or other errors must be made in writing to Seller within ten (10) days after delivery. This does not include transit shortage or damages. Failure to give such notice shall constitute acceptance and waiver of all such claims by Buyer.

A word about SPX FLOW Service Parts

We want to raise your awareness to the problem associated with the purchase of parts not manufactured to the high quality specifications of SPX FLOW.

In addition to our high quality, SPX FLOW parts are manufactured to meet regulatory agency authorization, approvals and certification (3A Sanitary standards, USDA, ASME, BISSC, and OSHA). Where applicable, materials used in construction of SPX FLOW parts conform to FDA regulations. Types of equipment include, but are not limited to rotary pumps, centrifugal pumps, homogenizers, scrape surface heat exchangers and plate heat exchangers. We bring this potentially serious problem to your attention in order to safeguard your best interest and those of your employees. If you have any questions, please feel free to call your local SPX FLOW contact.

Parts not manufactured to our specifications may cause damage to your SPX FLOW equipment and void all warranties. Use of parts that do not meet SPX FLOW specifications may cause property damages and serious bodily injury.

Policy regarding availability of service parts

SPX FLOW will attempt to remain in a position to supply replaceable parts during the normal life of any item of SPX FLOW equipment. This is contingent upon availability of tools, material and facilities of our own as well as of our suppliers.

After the expiration of this period, the supply of service parts will be limited to available stock of completed parts. If unable to supply the service part, drawings will be furnished when available to permit local manufacturing, if desired.

SPX FLOW reserves the right to improve, change or modify the construction of its equipment or any parts thereof without incurring any obligation to provide like changes to equipment previously sold.



Warnings

Safety Information

Electrical Hazard

A pump is normally powered by an electric motor. This creates a hazard of electrical shock which could cause severe injury or even loss of life.

To minimize the risk of this hazard:

All electric/electronic installation, maintenance, and service must be performed by trained and authorized electricians only.

All electric/electronic installation must comply with all applicable codes and standards including those established by OSHA (Occupational Safety and Health Administration).

Do Not perform any maintenance or service on the motor or any other electrical devices unless the electric power source has been turned off and Locked Out using a locking device for which only the person involved in the maintenance procedure has possession of the key.

Make installation suitable for a wet environment, including:

1. A power disconnect which can be locked in a power Off position and the key removed. This will allow maintenance or service to be performed without possibility of power being accidentally turned on.
2. Protection of all electric connections within a sealed junction box.
3. Proper grounding of the motor.
4. Protection from flooding. Do not install in an area which could fill with water to a level which contacts the motor.

Rotating Parts Hazard

Routine cleaning and maintenance procedures require pump disassembly. The pump contains close fitting parts which rotate during operation. Should the pump start unexpectedly while disassembled, severe injury could result.

To minimize the risk of this hazard:

1. Do Not assemble or disassemble the pump
2. Do Not remove the guard from the adapter
3. Do Not perform any maintenance or service on the motor or pump unless the power source has been turned off and Locked Out, where only the person involved in the maintenance procedure has possession of the key.

Warnings

High Temperature Hazard

Some pump applications may require processing of high temperature liquids and/or the use of high temperature cleaning/sanitizing solutions. Pumping high temperature liquids is considered to be hazardous and extreme care should be taken when handling such liquids.



To minimize the risk of this hazard:

1. All installation, maintenance and service of piping, valves and other controls must be performed by trained and authorized plumbers only. This applies to process piping and cleaning/sanitizing piping.
2. All plumbing installation must comply with all applicable codes and standards including those established by OSHA.
3. Do Not perform any maintenance or service on the motor or pump unless the power source has been turned off and Locked Out, where only the person involved in the maintenance procedure has possession of the key.
4. Never disconnect any lines or fittings (whether process or cleaning/sanitizing) or disassemble the pump until the line is no longer under pressure and the fluid inside is not hot or harmful.
5. Operating personnel must be authorized and trained.

High Pressure Hazard

Fluids processed by a pump are under pressure. This creates a hazard to personnel working in the area should a leak occur. Leaking high pressure fluid may cause injury by startling personnel or from actual contact with the leaking fluid.

To minimize the risk of this hazard:

1. All installation, maintenance and service of piping, valves and other controls must be performed by trained and authorized plumbers only. This applies to process piping and cleaning/sanitizing piping.
2. All plumbing installation must comply with all applicable codes and standards including those established by OSHA.
3. Never disconnect any lines or fittings (whether process or cleaning/sanitizing) or disassemble the pump when lines are under pressure.
4. Should a leak occur, immediately find the cause and stop the leak.

Explosion Hazard

Never operate the pump with both the inlet valve and the outlet valve in closed positions. If the pump runs with liquid in it, while the valves controlling the suction and discharge lines are both closed, the liquid in the pump will heat up and turn into vapor, causing a risk of explosion.

To eliminate the risk of explosion, it is strongly recommended that the following be included in the system:

1. A pressure relief device which relieves pressure and contains any discharge, or
2. A thermal/pressure overload device to isolate the pump motor in the event of excessive temperature/pressure.



Warnings

Leaking Fluid Hazard

Fluid leaks or spills may occur in any pumping system. This creates a hazard to personnel due to slippery floor conditions or contact with possibly hazardous fluids.

To minimize the risk of this hazard:

1. Always clean up leaks and spills immediately.
2. Find and correct the cause of the leak immediately.

The following important cautions describe ways to avoid incorrect operating procedures which will cause serious damage to the pump.

Cavitation

Cavitation is a condition within the pump which results in extreme hydraulic forces which can create a risk of severe damage to pump components. Cavitation makes a characteristic "rattling" noise. It is caused by operation with low fluid pressure at the pump inlet.

To minimize this risk:

Install and operate the pump so that NPSH (net positive suction head) available to the pump equals or exceeds the "NPSH required" as shown on the pump performance curve. To increase NPSH available:

1. Decrease the temperature of the liquid being pumped.
2. Increase the height of liquid supply level.
3. Decrease the suction line length and remove restrictions to flow, such as elbows, valves, etc.
4. Increase the suction line size (diameter).
5. Reduce the pump flow rate (throttle discharge).

Corrosion Pitting

Stainless steel is subject to a risk of corrosion when improperly cleaned or sanitized.

To minimize this risk:

1. Never use steel wool or a wire brush to clean stainless steel surfaces. Iron particles will embed and cause corrosion pits. Use a non-metallic brush or scrub pad for cleaning when required.
2. Never allow prolonged contact of sanitizing solutions or other corrosive cleaning chemicals with stainless steel. Only use sanitizing solutions immediately prior to processing.

Warnings

Motor Overload

Depending on the impeller diameter and motor horsepower, there is a risk the pump motor will overload if operated with a fully opened, unrestricted discharge.

To minimize this risk:



1. Before operating the pump, review performance curve and application giving consideration to motor horsepower and impeller diameter versus expected discharge flow rate and pressure. If the pump is operated with less than expected discharge pressure, the flow rate will increase and the load on the motor will increase.
2. Install a throttling type valve in the discharge piping to allow control of the pump discharge flow rate during initial operation. The valve may be removed later when the system is proven to supply adequate discharge pressure to prevent overload.

Impeller Shaft Location

The location of the impeller shaft on the motor shaft is critical for correct pump operation and to obtain maximum operating efficiency.

APV brand Centrifugal Pumps are designed to achieve excellent operating efficiency. This efficiency is possible, in part, because of precision manufacturing of the pump components. The impeller must be precisely located between the casing and backplate to take full advantage of the pump's operating efficiency. Incorrect location of the impeller shaft may cause the impeller to contact the casing or the backplate during operation and cause extensive damage to the pump.

The procedures for correctly locating the impeller shaft are described in the Maintenance section. This should be referred to whenever:

1. A new pump is installed onto a motor or pedestal.
2. The impeller shaft is loosened or removed from the motor or pedestal shaft.
3. A replacement casing or backplate is installed.



Sectional Drawing

W+

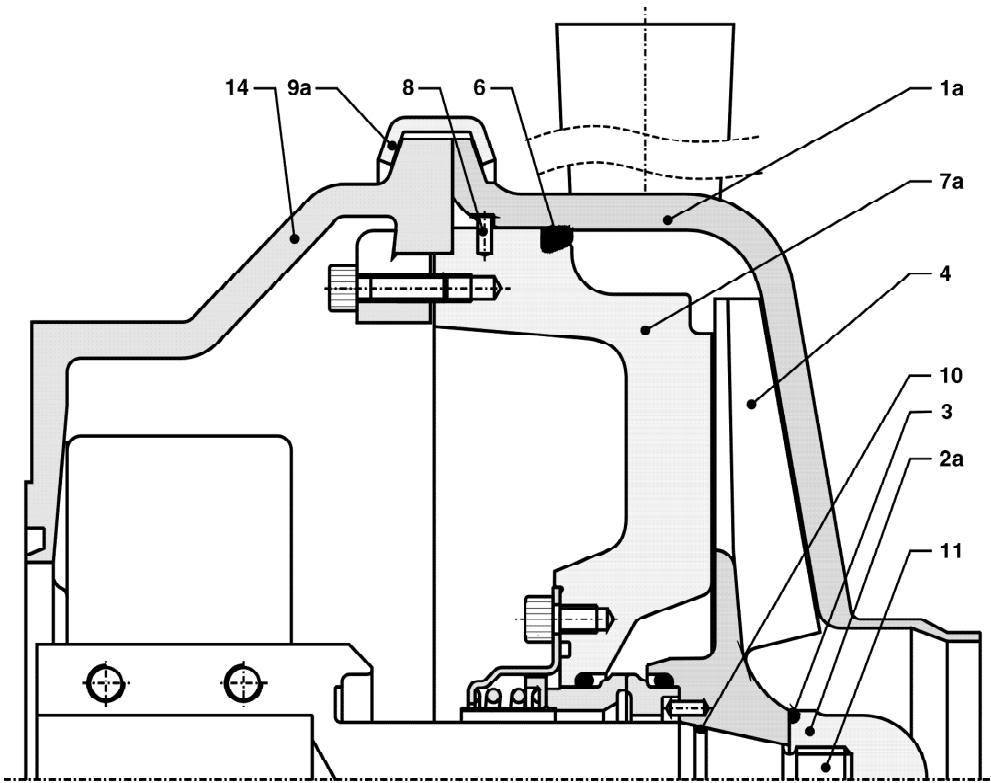

- 1a: Pump housing
- 2a: Cap nut
- 3: O-ring
- 4: Impeller
- 6: O-ring
- 7a: Back plate
- 8: Locating pin
- 9a: Clamp ring
- 10: O-ring
- 11: Shaft
- 14: Motor adapter

Section 1 Single seal for shaft size $\varnothing 25$ and $\varnothing 35$

Section 2 Double seal with liquid/steam flushing for shaft size $\varnothing 25$ and $\varnothing 35$

- 5.1: Seal housing
- 5.3: Pressure ring
- 5.4: Drain pipe
- 5.5: O-rings
- 5.6: Stationary seal face
- 5.7: Rotary seal face
- 5.8: Pin
- 5.9: Seal housing
- 5.10: O-ring
- 5.11: Pressure ring

Section 1 - Single seal for shaft size $\varnothing 25$ and $\varnothing 35$

Section 2 - Double seal with liquid/steam flushing for shaft size $\varnothing 25$ and $\varnothing 35$

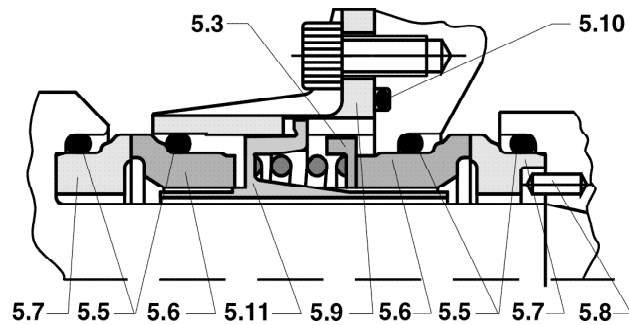
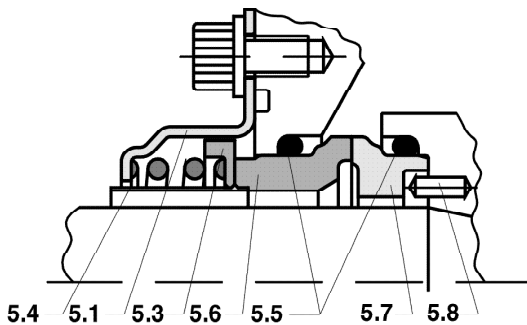

1. Introduction to the W+ program

1.1 The W+ range

This manual covers all the standard versions of the W+ pump as well as aseptic versions (Wa+ pumps) and pumps with inducer (Wi+ pumps). Check the pump's nameplate to make sure that you have one of the above versions.

Units are designed and constructed to meet the requirements of the 3A sanitary standards for cleanability of processing equipment.

1.2 W+ pump features

Standard Options are available in the W+ range:

- with frame and feet
- with shaft seal in carbon/SiC or SiC/SiC
- with o-rings in EPDM or FPM (Viton) (Kalrez and possibly others)
- with single or double shaft seal prepared for water-flushed or steam-flushed shaft seal

Additional Options:

- Heating/Cooling Jacket
- Casing Drain
- Portable 2- and 3-wheel cart
- Inducer (Wi+)
- Double o-ring sealing of pump body fitted for sterile flushing (Wa+)
- Heavy duty clamp ring, increasing the pump's maximum permissible outlet pressure to 360 PSIG (available for W+30/120, W+55/35, W+55/60, W+60/110, W+70/40) or 290 PSIG (available for W+80/80).
- W+ pumps can be supplied with all standard welded ferrules (tri-clamp, bevel seat, ISO, etc.) or with special aseptic connections prepared for sterile flushing (Wa+).

1.3 Identifying the pump model

A nameplate as is fitted on the motor adapter.

Example:

Serial No.: Use the serial number whenever requesting information on service parts.

Type: The type indicates the type of pump, such as W+10/8, W+22/20, etc.

Year: Indicates the year of manufacture.

Order No.: Indicates SPX FLOW's sales order number.



2. Installation of the Pump

2.1 Positioning

The pump must be positioned so that the suction pipe is as short as possible and there is a sloping gradient towards the suction port. Keep the number of valves, bends and tee-pieces on the suction side to an absolute minimum.

There must be sufficient space around the pump for piping and access for maintenance.

2.2 Lining up the pipe system

Line up the pipes carefully to the pump suction and discharge nozzles. Make sure that the pipe system is adequately supported by pipe supports so that the pump body is not subject to strains and weight from the pipe system.

2.3 Power supply

All electrical installation must comply with all applicable codes and standards including those established by the Occupational Safety and Health Administration (OSHA).

Install a main power disconnect on-off switch that can be locked in the power off position and have the key removed when service is performed.

Thoroughly read the motor manufacturer's instructions before making installation.

The motor should be connected such that the direction of rotation of the motor (and thus the impeller) is counterclockwise when viewed from the front towards the suction nozzle of the pump body (Fig. 1).

2.4 Water supply for water-flushed shaft seal

Pumps with a water-flushed shaft seal have two hose connectors on the seal flange. The hose connectors are G1/8 BSPP and fit 1/4 inch plastic tubing. A flush flow of 4-8 gallons/hour is required. Maximum pressure is 100 PSIG.

The hose connection in the seal flange should always be positioned vertically with the fluid inlet below and the outlet above. See Fig. 2.

Water consumption can be limited by installing a solenoid valve on the supply side for the flushing water. The open/close function of the solenoid valve can be controlled by the pump's start/stop sequence.

Do not use the flushing water connectors for steam condensate. If you want to use steam as the barrier medium, special aseptic piping is required. See section 2.5 for connection.

2.5 Connecting steam or steam condensate for aseptic use

Shaft seals for aseptic use are supplied with two hose connectors (G1/8 BSPP x 6mm/4mm PTFE Tubing).

Steam can be used at temperatures up to 300°F (150°C) and pressures up to 72 PSIG (5 bar).

Fig. 1: Direction of shaft rotation

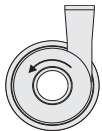
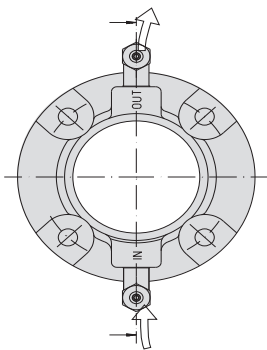
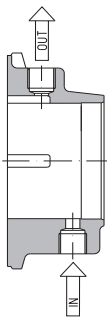

Fig. 2: Seal flange positioned vertically



3. Before Start-up

Note: for numbered items, see assembly drawing on page 10.

Before starting the pump, dismantle and clean the suction pipe. Any foreign material in the pump should be removed.

3.1 Checking the pump body for foreign material

Remove the pump body as described below. See page 10 for the referenced assembly drawing.

1. Disconnect the power supply.
2. Remove the pump body (item 1a) by undoing the clamp ring (item 9a) or body screws and carefully pull off the pump body.
3. Turn the impeller (item 4) to ensure that there is no foreign material behind it.
4. If there is any foreign material in the pump, remove it.
5. When the pump body is clean and free of foreign material, reassemble the pump.

Mount the pump body as described below:

6. Check that the locating pin in the top of the back plate (item 8, where fitted) mates with the detent in the pump body. Carefully, to avoid damaging the o-ring, press the pump body (item 1a) in over the o-ring (item 6). Fasten with the clamp ring (item 9a) or body screws. If using body screws, lubricate the threads and observe the correct tightening torque: See "Required torques for housing clamps/screws" on page 18.
7. Install suction and discharge pipes. Check that the pipe unions have been tightened properly and that pipe supports have been fitted.



Fig. 3: Direction of rotation

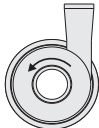

To make the pump body easier to fit, we recommend that you give the O-ring a thin layer of food-approved, acid-free grease or soap.

3.2 Testing the pump

To check that the pump is working satisfactorily, pour water into the pump and start it for a moment. Check the direction of rotation (Fig. 3). Listen for any unusual noises.

In pumps with water-flushed or steam-flushed shaft seals, the seal chamber must be filled with water/steam.

Never allow the pump to run without liquid, as this will ruin the shaft seal.

4. Putting the Pump into Service

Check the following before starting the pump:

- that the shaft guard has been fitted properly
- that there is free access for liquid
- that the valve on the discharge side is closed.

The valve on the discharge side (if fitted) is closed during start-up to reduce motor starting current, but should be opened again as soon as the pump has been started.

4.1 Flushing water/steam/condensate etc.

In pumps with a flushed shaft seal, check that the supply of flushing medium is open and that the flow of the medium is adequate (approx. 4-8 gallons/hour).



5. Maintenance

Note: for numbered items, see assembly drawing on page 10.

Pump disassembly



Shaft Seal disassembly

Checking parts for wear



5.1 Checking the shaft seal

Check the pump's shaft seal for leaks on a regular basis. If the shaft seal is leaking, replace it or its relevant parts as described below.

5.2 Replacing the shaft seal

See page 10 for the referenced assembly drawing.

The assembly drawing shows the position and construction of the shaft seal - both standard seals and seals with water/steam flushing.

To replace the shaft seal, it is necessary to dismantle the pump as described below.

1. Disconnect the power supply in the motor isolator by removing the fuses and disconnecting the cables.
2. Turn off the steam and flushing water supply.
3. Close the inlet and discharge of the pump, and make sure that there is no liquid in the pump body.

If the pump is used for hot and/or aggressive liquids, special precautions must be taken. In such cases, observe the local regulations for personal protection when working with these products.

4. Once the inlet and outlet pipes have been closed properly, release the clamp ring (page 10, item 9a) or body screws, take off the pump body (item 1a) and remove the impeller (item 4).
5. Remove the stationary seal face (item 5.6) mounted in the back plate (item 7a) with your fingers.
6. Remove the o-ring (item 5.5) from the stationary seal face.
7. Use your fingers to remove the rotary seal face (item 5.7) mounted in the impeller (item 4).
8. Remove the o-ring (page 10, item 5.5) from the rotary seal face.
9. Clean the stator and rotary seal face locations, if necessary with air or water.
- 9a. In the case of water-flushed/aseptic shaft seals, the back plate must be removed to dismantle the rear shaft seal. The rear stationary seal face (item 5.6) is mounted in the pressure ring (item 5.11) and the rotary seal face (item 5.7) is mounted on the shaft (item 11). These are removed in the same way as the front seal components.
10. Check the o-rings (item 5.5) for signs of cracks, lack of elasticity, brittleness and/or chemical attack. Replace worn or defective parts.
11. Check the stationary seal face (item 5.6) and rotary seal face (item 5.7) for signs of wear. The wearing surfaces must be completely free of scratches/cracks. If not, the rotary seal face and stationary seal face must both be replaced.
- 11a. In the case of water-flushed shaft seals, check the rear seal rings (item 5.7, 5.6) for wear, and replace if necessary.

5. Maintenance

Fitting

Note: for numbered items, see assembly drawing on page 10.

Positioning the water supply connections



12. Fit new o-rings on the stationary seal face (item 5.6) and rotary seal face (item 5.7). Take extra care not to leave finger prints or contaminants on the seal faces during assembly.
Note. Remember to moisten these with water.
13. Fit the rotary seal face (item 5.7) on the impeller without using tools.
Note. The "notch" in the rotary seal face must be located so that it mates with the driving pin (item 5.8) in the impeller hub.
- 13a. In the case of water-flushed/aseptic seals, also fit a rotary seal face (item 5.7) with its o-ring (item 5.5) in the location on the shaft, again without using tools.
14. Fit drain pipe (item 5.4) to the back of the stationary seal face (item 5.6). Fit the stationary seal face (item 5.6) on the back plate without using tools.
Note. The "notches" in the stationary seal face must mate with the driving dogs on the carrier in the back plate. Check that the stationary seal face is positioned so that it slides backwards and forwards easily in the back plate.
- 14a. Where there are water-flushed/aseptic seals, fit the stationary seal faces (item 5.6) into the seal cover (item 5.9) and back plate (item 7a).
15. After fitting, clean the wearing surfaces.
- 15a. For liquid-flushed/aseptic seals, remount the back plate (item 7a).
16. Fit the impeller (item 4) and secure it with the cap nut/inducer (item 2a). Lubricate the threads and use the proper tightening torque:

M10:	33 lb·ft	(45 Nm)	(uses 8 mm Allen wrench)
M14:	52 lb·ft	(70 Nm)	(uses 22 mm Allen wrench)
M20:	148 lb·ft	(200 Nm)	(uses 30 mm Allen wrench)

 Reference the table "Required torques for cap nuts" on page 18.
17. Check that the locating pin in the top of the back plate (item 8, where fitted) mates with the detent in the pump body. Carefully, to avoid damaging the o-ring, press the pump body (item 1a) in over the o-ring (item 6) and fasten with the clamp ring (item 9a) or body screws, observing the correct tightening torque. See the table on page 18, "Required torques for housing clamp/screws."



5. Maintenance

Fig. 4: Unscrew motor flange bolts

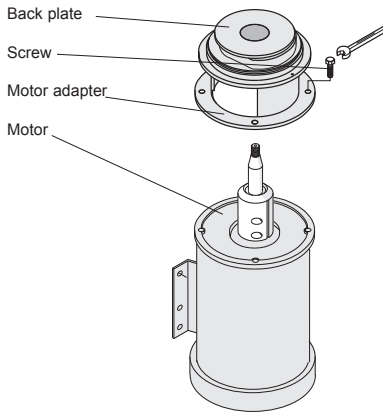

Fig. 5: Loosen screws

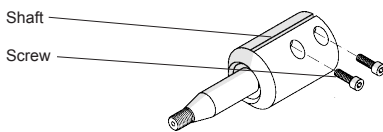

Fig. 6: Mount pump shaft

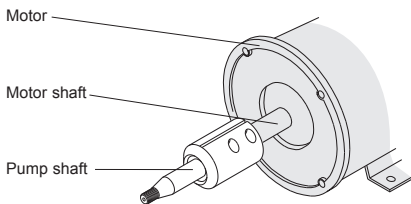

Fig. 8: Balance hole position

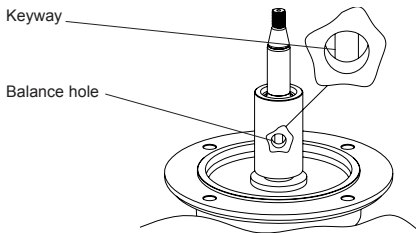
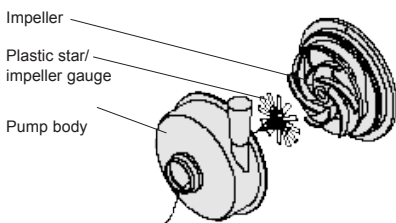

Fig. 7: Place plastic star against impeller



5.3 Replacement of motor

The standard motor for the W+ pump has a locked front bearing. If the motor is replaced, the new motor must also have a locked front bearing. The motor bearing is enclosed and permanently lubricated.

Follow the instructions below when replacing the motor. For replacement of bearings, see the motor supplier's service instructions.

1. Lock Out power supply, then disconnect the pump and motor from the system.
2. Remove the pump body. See para 5.2, points 1-4.
3. Remove the impeller.
4. If possible, stand the pump on end. See Fig. 4.
5. Undo the four motor flange bolts between the motor and motor adapter and remove them. See Fig. 4.
6. Lift the back plate, motor adapter and spacer flange (where fitted), which are still bolted together, up and off the shaft. See Fig. 4.
7. See Fig. 5. Loosen the screws in the base of the shaft, pull the shaft off and replace the motor.
8. See Fig. 6. Before remounting the pump shaft, remove any dirt and grease from the motor shaft and the base's internal clamping surfaces. Mount the pump shaft loosely. Position the balance hole above the keyway. See Fig. 8.
9. Fit the back plate and motor adapter over the shaft.
10. Apply "Never-Seez" or equivalent to the bolt threads and tighten the bolts.
11. Turn the pump back so that it stands on its legs.
12. Fit the impeller (item 4) and secure it with the cap nut/inducer (item 2a). Remember to use the proper tightening torque:

M10: 33 lb·ft (45 Nm) (uses 8 mm Allen wrench)

M14: 52 lb·ft (70 Nm) (uses 22 mm Allen wrench)

M20: 148 lb·ft (200 Nm) (uses 30 mm Allen wrench)

13. Place the plastic star against the impeller. See Fig. 7.
14. Fit the pump body (item 1a) with the clamp ring (item 9a).
15. Push the shaft (item 11) forward until the impeller (item 4) is touching the plastic star/impeller gauge. See Fig. 9.
16. Apply "Never-Seez" or equivalent to the screw threads. Tighten the shaft screws. Remember to use the proper tightening torque for the screws:

M8: 22 lb·ft (30 Nm) (uses 6 mm Allen wrench)

M10: 41 lb·ft (55 Nm) (uses 8 mm Allen wrench)

17. Remove the star/impeller gauge by pulling it out through the inlet.

Replacement star/impeller gauge:

part no.	size	part no.	size
L274534	4.5" (115 mm)	L260406	9" (230 mm)
L259776	5.9" (150 mm)	L267637	11" (280 mm)



5. Maintenance

Fig. 9: Push shaft forward

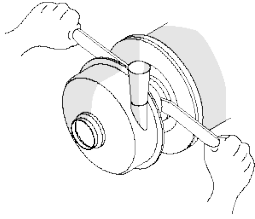

5.4 Recommended inventory of spare parts

Seal set

We recommend that you keep both seal kits and service kits for the W+ pumps in stock. The seal kit for the W+ pump consists of the wearing parts of the pump, as specified on page 30.

Service kit

The service kit is made up of a number of the main components of the pump which are not wearing parts, but which you still may have to replace: shaft, impeller, cap nut and fixing kit.

The table below shows the recommended inventory of spare parts for normal operation and in cases where there are special needs - for example, 24-hour operation, operation with abrasive media, or processes that are sensitive to even the shortest production stoppage.

Wearing parts (seal kit, see page 30)

	No. of pumps in service		
	0-5	5-20	> 20
	Sets	Sets	Sets/ 10 pumps
Normal operation	2	3	1
Special needs	3	6	2

Service parts (shaft, impeller, cap nut, see page 25-27, fixing kit, see page 28).

	No. of pumps in service		
	0-5	5-20	> 20
	Sets	Sets	Sets/ 10 pumps
Normal operation	0	1	1
Special needs	1	2	1

6. Technical data

6.1 Maximum permissible outlet pressure

The maximum pump outlet pressures specified below must not be exceeded (applies to water at 68°F/20°C).

Max. 260 psig (18 bar): W+10/8, W+22/20, W+30/80, W+35/55, W+35/35, W+110/130

Max. 200 psig (14 bar): W+25/210, W+30/120, W+50/8, W+55/35, W+55/60, W+60/110, W+65/350, W+70/40, W+80/80

The above values also apply to the corresponding models in the Wa+ and Wi+ versions.

Subject to change.



6. Technical data

6.2 Required torque

Pump Model	Motor Frame	Shaft size	Screw Size	Screw Torque	
				(N-m)	lb-ft
W+10/8	56C	25	M8x25	30	22
W+22/20, W+35/35, W+35/55, W+55/35	56TC	25	M8x25	30	22
W+22/20, W+30/80, W+35/35, W+35/55, W+55/35	143-145TC	25	M8x30	30	22
W+30/120, W+55/60, W+70/40	143-145TC	35	M8x30	30	22
W+10/8, W+50/8	143-145TC	25	M8x30	30	22
W+22/20, W+30/80, W+35/35, W+35/55, W+55/35	182-184TC	25	M8x30	30	22
W+30/120, W+55/60, W+60/110, W+70/40, W+80/80, W+110/130	182-184TC	35	M8x30	30	22
W+50/8	182-184TC	25	M8x30	30	22
W+22/20, W+30/80, W+35/35, W+35/55, W+55/35	213-215TC	25	M10x30	55	41
W+25/210, W+30/120, W+55/60, W+60/110, W+65/350, W+70/40, W+80/80, W+110/130	213-215TC	35	M8x30	30	22
W+50/8	213-215TC	25	M10x30	55	41
W+30/80, W+35/35, W+35/55, W+55/35	254-256TC	25	M10x30	55	41
W+25/210, W+30/120, W+55/60, W+60/110, W+65/350, W+70/40, W+80/80, W+110/130	254-256TC	35	M10x30	55	41
W+25/210, W+30/120, W+55/60, W+60/110, W+65/350, W+70/40, W+80/80, W+110/130	324-326TC	35	M10x30	55	41
W+25/210, W+60/110, W+65/350, W+80/80, W+110/130	364-326TC	35	M10x30	55	41
W+65/350, W+80/80, W+110/130	405TSC	35	M10x30	55	41

Torque the stub shaft bolts according to the size of the screws listed:

M8: 22 lb-ft (30 Nm), uses 6mm Allen wrench; M10: 41 lb-ft (55 Nm), uses 8mm Allen wrench

Required torques for housing clamp/screws				
Pump type	mounting	Size	required torques	
W+10/8	Clamp	M6	No torque requirements	
W+22/20	Clamp	M10	55 Nm	41 lb-ft
W+30/80	Clamp	M10	55 Nm	41 lb-ft
W+35/35	Clamp	M10	55 Nm	41 lb-ft
W+35/55	Clamp	M10	55 Nm	41 lb-ft
W+50/8	Clamp	M10	55 Nm	41 lb-ft
W+55/35	Clamp	M10	55 Nm	41 lb-ft
W+25/210	Screws	M10x30	55 Nm	41 lb-ft
W+30/120	Clamp	M10	55 Nm	41 lb-ft
W+55/60	Clamp	M10	55 Nm	41 lb-ft
W+60/110	Clamp	M10	55 Nm	41 lb-ft
W+65/350	Screws	M8x25	30 Nm	22 lb-ft
W+70/40	Clamp	M10	55 Nm	41 lb-ft
W+80/80	Clamp	M10	55 Nm	41 lb-ft
W+110/130	Screws	M10x35	55 Nm	41 lb-ft

Required torques for cap nuts				
Pump type	Shaft Ø	Cap Nut	required torques	
W+10/8	Ø25	M10	45 Nm	33 lb-ft
W+50/8	Ø25	M10	45 Nm	33 lb-ft
W+22/20	Ø25	M14	70 Nm	52 lb-ft
W+30/80	Ø25	M14	70 Nm	52 lb-ft
W+35/35	Ø25	M14	70 Nm	52 lb-ft
W+35/55	Ø25	M14	70 Nm	52 lb-ft
W+55/35	Ø25	M14	70 Nm	52 lb-ft
W+25/210	Ø35	M20	200 Nm	148 lb-ft
W+30/120	Ø35	M20	200 Nm	148 lb-ft
W+55/60	Ø35	M20	200 Nm	148 lb-ft
W+60/110	Ø35	M20	200 Nm	148 lb-ft
W+65/350	Ø35	M20	200 Nm	148 lb-ft
W+70/40	Ø35	M20	200 Nm	148 lb-ft
W+80/80	Ø35	M20	200 Nm	148 lb-ft
W+110/130	Ø35	M20	200 Nm	148 lb-ft

M10: uses 8 mm Allen wrench

M14: uses 22 mm Allen wrench

M20: uses 30 mm Allen wrench

7. W+ Spare Parts, Dimensions

7.1 Pump Dimensions

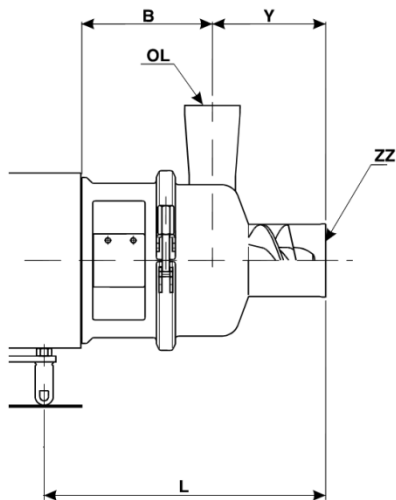
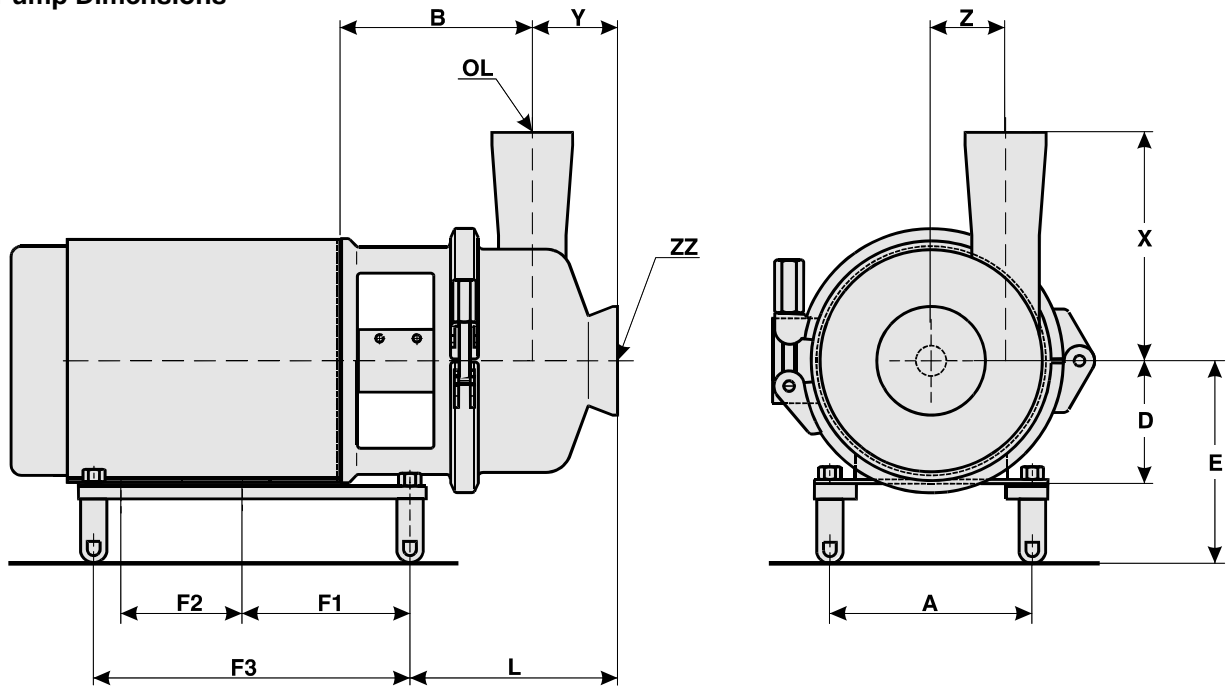

WI+ pump

Inlet/Outlet Size	Bevel Seat	Threaded PV	TRI Clamp	APC Clamp	ISS	Male Pipe Thread	150#Flange
1.5" (38 mm)	0.687" (17 mm)	0.687" (17 mm)	1.125" (29 mm)	0.687" (17 mm)	1.125" (29 mm)	1.625" (41 mm)	1.187" (30 mm)
2.0" (51 mm)	0.750" (19 mm)	0.750" (19 mm)	1.125" (29 mm)	0.750" (19 mm)	1.125" (29 mm)	1.687" (43 mm)	1.187" (30 mm)
2.5" (63 mm)	0.844" (21 mm)	0.844" (21 mm)	1.125" (29 mm)	0.844" (21 mm)	1.125" (29 mm)	2.187" (55 mm)	1.187" (30 mm)
3.0" (76 mm)	0.906" (23 mm)	0.906" (23 mm)	1.125" (29 mm)	0.906" (23 mm)	1.125" (29 mm)	2.250" (57 mm)	1.500" (38 mm)
4.0" (102 mm)	1.000" (25 mm)	1.000" (25 mm)	1.125" (29 mm)	1.000" (25 mm)	0.844" (21 mm)	2.000" (51 mm)	1.500" (38 mm)
6.0" (152 mm)	N/A	N/A	1.500" (38 mm)	N/A	N/A	O/A	2.156" (55 mm)



7. W+ Spare Parts, Dimensions

7.1 Pump Dimensions

Pump Type	Motor Size	F1	F2	F3	D	A	E	L W+	L W+	B	ZZ	OL	Z	X (Butt weld)	Y (Butt weld)
W+10/8	56C	4.00 (101.6)	3.00 (76.2)	8.5 (215.9)	3.50 (88.9)	4.88 (123.9)	7.00 (177.8)	5.10 (129)	-----	5.43 (138)	1.5 (38.6)	1.0 (25.4)	1.772 (45)	3.35 (85)	1.26 (32)
	143TC	3.75 (93.5)	4.00 (101.6)	10.25 (260.4)		5.50 (139.7)		5.15 (131)							
	145TC		5.00 (127)												
W+22/20	56C	4.00 (101.6)	3.00 (76.2)	8.5 (215.9)	3.50 (88.9)	4.88 (123.9)	7.00 (177.8)	5.72 (145)	8.95 (227)	5.98 (152)	2.0 (51.6)	2.0 (51.6)	2.60 (66)	8.47 (215)	1.34 (34)
	143TC	3.75 (93.5)	4.00 (101.6)	10.25 (260.4)		5.50 (139.7)		6.25 (159)	9.53 (242)						
	145TC		5.00 (127)												
	182TC	4.37 (111)	4.50 (114.3)	11.37 (288.8)	4.50 (114.3)	7.50 (190.5)	8.00 (203.2)	7.35 (186)	10.55 (268)	7.01 (178)	*Wl+ 3.0 (76.1)				*Wl+ 4.57 (116)
	184TC		5.50 (139.7)												
	213TC	5.38 (136.7)	5.50 (139.7)	13.88 (352.6)	5.25 (133.4)	8.50 (215.9)	8.75 (222.3)	7.22 (183.4)	10.45 (265.5)						
	215TC		7.0 (177.8)												
W+25/210	213TC	5.38 (136.7)	5.50 (139.7)	13.88 (352.6)	5.25 (133.4)	8.50 (215.9)	8.75 (222.3)	8.95 (227)	15.36 (390)	6.69 (170)	6.06 (154)	4.09 (104)	5.59 (142)	9.33 (237)	3.39 (86)
	215TC		7.0 (177.8)								DN150				
	254TC	6.50 (165.1)	8.25 (209.6)	18.00 (457.2)	6.25 (158.8)	10.00 (254)	9.75 (267.7)	8.96 (228)	15.38 (391)	7.32 (186)					
	256TC		10.00 (254)												
	284TSC	6.50 (165.1)	9.50 (241.3)	19.00 (482.6)	7.00 (177.8)	11.00 (279.4)	10.50 (266.7)	8.13 (207)	14.55 (370)	6.50 (165)					
	286TSC		11.00 (279.4)												
	324TSC	7.00 (177.8)	10.50 (266.7)	20.50 (520.7)	8.00 (203.2)	12.50 (317.5)	11.50 (292.1)	9.16 (233)	15.58 (396)	7.52 (191)	*Wl+ 6.06 (154)				*Wl+ 9.80 (249)
	326TSC		12.00 (304.8)												
	364TSC	7.00 (177.8)	11.25 (285.8)	20.50 (520.7)	9.00 (228.6)	14.00 (355.6)	12.50 (342.9)	9.79 (249)	16.21 (412)						
W+30/80	56C	4.00 (101.6)	3.00 (76.2)	8.5 (215.9)	3.50 (88.9)	4.88 (123.9)	7.00 (177.8)	7.65 (194)	10.84 (275)	6.10 (155)	4.0 (102)	3.0 (76.2)	2.76 (70)	8.47 (215)	3.15 (80)
	143TC	3.75 (93.5)	4.00 (101.6)	10.25 (260.4)		5.50 (139.7)		8.21 (208)	11.38 (289)						
	145TC		5.00 (127)												
	182TC	4.37 (111)	4.50 (114.3)	11.37 (288.8)	4.50 (114.3)	7.50 (190.5)	8.00 (203.2)	9.24 (235)	12.44 (316)	7.09 (180)					
	184TC		5.50 (139.7)												
	213TC	5.38 (136.7)	5.50 (139.7)	13.88 (352.6)	5.25 (133.4)	8.50 (215.9)	8.75 (222.3)	9.11 (231)	12.29 (312)	7.09 (180)	*Wl+ 4.0 (102)				*Wl+ 6.34 (161)
	215TC		7.0 (177.8)												
	254TC	6.50 (165.1)	8.25 (209.6)	18.00 (457.2)	6.25 (158.8)	10.00 (254)	9.75 (267.7)	9.11 (232)	12.31 (313)	7.71 (196)					
	256TC		10.00 (254)												
W+30/120	143TC	3.75 (93.5)	4.00 (101.6)	10.25 (260.4)	3.50 (88.9)	5.50 (139.7)	7.00 (177.8)	8.56 (218)	13.47 (342)	6.14 (156)	4.0 (102)	3.0 (76.2)	3.74 (95)	9.84 (250)	3.47 (88)
	145TC		5.00 (127)												
	182TC	4.37 (111)	4.50 (114.3)	11.37 (288.8)	4.50 (114.3)	7.50 (190.5)	8.00 (203.2)	9.63 (245)	14.53 (369)	7.17 (182)					
	184TC		5.50 (139.7)												
	213TC	5.38 (136.7)	5.50 (139.7)	13.88 (352.6)	5.25 (133.4)	8.50 (215.9)	8.75 (222.3)	9.50 (241)	14.38 (365)						
	215TC		7.0 (177.8)												
	254TC	6.50 (165.1)	8.25 (209.6)	18.00 (457.2)	6.25 (158.8)	10.00 (254)	9.75 (267.7)	9.51 (242)	14.40 (366)	7.80 (198)					
	256TC		10.00 (254)												
	284TSC	6.50 (165.1)	9.50 (241.3)	19.00 (482.6)	7.00 (177.8)	11.00 (279.4)	10.50 (266.7)	8.84 (225)	13.73 (349)	7.13 (181)	*Wl+ 4.0 (102)				*Wl+ 8.35 (212)
	286TSC		11.00 (279.4)												
	324TSC	7.00 (177.8)	10.50 (266.7)	20.50 (520.7)	8.00 (203.2)	12.50 (317.5)	11.50 (292.1)	10.53 (268)	15.42 (392)	8.19 (208)					

Tolerances:	Y: +0", -0.197"	X: +0.197", -0"	OL,ZZ: nominal	B: ±0.197"	L: ±0.197"	Others: ±0.079"
-------------	-----------------	-----------------	----------------	------------	------------	-----------------



7. W+ Spare Parts, Dimensions

7.1 Pump Dimensions

Pump Type	Motor Size	F1	F2	F3	D	A	E	L	L WI+	B	ZZ	OL	Z	X (Butt weld)	Y (Butt weld)					
W+35/35	56C	4.00 (101.6)	3.00 (76.2)	8.5 (215.9)	3.50 (88.9)	4.88 (123.9)	7.00 (177.8)	5.33 (145)	8.40 (213)	5.16 (131)	2.5 (63.5)	2.0 (51.6)	3.27 (83)	9.06 (230)	1.77 (45)					
	143TC	3.75 (93.5)	4.00 (101.6)	10.25 (260.4)		5.50 (139.7)		5.89 (150)	8.98 (228)											
	145TC		5.00 (127)		4.50 (114.3)	7.50 (190.5)	8.00 (203.2)	6.91 (175)	9.96 (253)	6.14 (156)										
	182TC	4.37 (111)	5.50 (139.7)	11.37 (288.8)												5.25 (133.4)	8.50 (215.9)	8.75 (222.3)	6.78 (172)	9.85 (250)
	184TC	5.38 (136.7)	7.0 (177.8)	13.88 (352.6)	5.25 (133.4)	8.50 (215.9)	8.75 (222.3)	6.78 (172)	9.85 (250)	6.14 (156)						*WI+ 3.0 (76.1)				*WI+ 4.84 (123)
	213TC		5.50 (139.7)																	
	215TC	6.50 (165.1)	8.25 (209.6)	18.00 (457.2)	6.25 (158.8)	10.00 (254)	9.75 (267.7)	6.79 (173)	9.87 (251)	6.77 (172)										
	254TC		10.00 (254)																	
256TC																				
W+35/55	56C	4.00 (101.6)	3.00 (76.2)	8.5 (215.9)	3.50 (88.9)	4.88 (123.9)	7.00 (177.8)	6.23 (158)	10.00 (254)	5.75 (146)	3.0 (76.7)	2.5 (63.5)	3.15 (80)	8.27 (210)	2.09 (53)					
	143TC	3.75 (93.5)	4.00 (101.6)	10.25 (260.4)		5.50 (139.7)		6.80 (172)	10.55 (268)											
	145TC		5.00 (127)		4.50 (114.3)	7.50 (190.5)	8.00 (203.2)	7.82 (198)	12.44 (316)	6.73 (171)										
	182TC	4.37 (111)	5.50 (139.7)	11.37 (288.8)												5.25 (133.4)	8.50 (215.9)	8.75 (222.3)	7.69 (195)	14.14 (359)
	184TC	5.38 (136.7)	7.0 (177.8)	13.88 (352.6)	5.25 (133.4)	8.50 (215.9)	8.75 (222.3)	7.69 (195)	14.14 (359)	6.73 (171)						*WI+ 4.0 (102)				*WI+ 5.83 (148)
	213TC		5.50 (139.7)																	
	215TC	6.50 (165.1)	8.25 (209.6)	18.00 (457.2)	6.25 (158.8)	10.00 (254)	9.75 (267.7)	7.70 (195)	18.45 (468)	7.36 (187)										
	254TC		10.00 (254)																	
256TC																				
W+50/8	143TC	3.75 (93.5)	4.00 (101.6)	10.25 (260.4)	3.50 (88.9)	5.50 (139.7)	7.00 (177.8)	5.85 (149)	5.40 (137)	1.5 (38.6)	1.0 (25.6)	4.25 (108)	5.91 (150)	1.50 (38)						
	145TC		5.00 (127)			4.50 (114.3)	7.50 (190.5)	8.00 (203.2)							6.91 (176)					
	182TC	4.37 (111)	5.50 (139.7)	11.37 (288.8)	5.25 (133.4)				8.50 (215.9)											
	184TC	5.38 (136.7)	7.0 (177.8)	13.88 (352.6)	5.25 (133.4)	8.50 (215.9)	8.75 (222.3)	6.78 (172)	6.42 (163)											
	213TC		5.50 (139.7)												18.00 (457.2)	6.25 (158.8)	10.00 (254)	9.75 (267.7)	7.70 (195)	18.45 (468)
	215TC	6.50 (165.1)	8.25 (209.6)	18.00 (457.2)	6.25 (158.8)	10.00 (254)	9.75 (267.7)	7.70 (195)	18.45 (468)						7.36 (187)					
254TC	10.00 (254)																			
256TC																				
W+55/35	56C	4.00 (101.6)	3.00 (76.2)	8.5 (215.9)	3.50 (88.9)	4.88 (123.9)	7.00 (177.8)	6.75 (171)	9.15 (232)	5.47 (139)	2.5 (64.1)	1.5 (38.6)	4.25 (108)	7.68 (195)	2.87 (73)					
	143TC	3.75 (93.5)	4.00 (101.6)	10.25 (260.4)		5.50 (139.7)		7.31 (185)	9.71 (246)											
	145TC		5.00 (127)		4.50 (114.3)	7.50 (190.5)	8.00 (203.2)	8.37 (212)	10.77 (273)	6.50 (165)										
	182TC	4.37 (111)	5.50 (139.7)	11.37 (288.8)												5.25 (133.4)	8.50 (215.9)	8.75 (222.3)	8.24 (209)	10.64 (270)
	184TC	5.38 (136.7)	7.0 (177.8)	13.88 (352.6)	5.25 (133.4)	8.50 (215.9)	8.75 (222.3)	8.24 (209)	10.64 (270)	*WI+ 3.0 (76.1)									*WI+ 5.28 (134)	
	213TC		5.50 (139.7)																	18.00 (457.2)
	215TC	6.50 (165.1)	8.25 (209.6)	18.00 (457.2)	6.25 (158.8)	10.00 (254)	9.75 (267.7)	8.25 (209)	10.65 (270)											7.13 (181)
	254TC		10.00 (254)																	
256TC																				

Tolerances:	Y: +0" -0.197"	X: +0.197" -0"	OL;ZZ: nominal	B: ±0.197"	L: ±0.197"	Others: ±0.079"
-------------	-------------------	-------------------	----------------	------------	------------	-----------------



7. W+ Spare Parts, Dimensions

7.1 Pump Dimensions

Pump Type	Motor Size	F1	F2	F3	D	A	E	L	L WI+	B	ZZ	OL	Z	X (Butt weld)	Y (Butt weld)	
W+55/60	143TC	3.75 (93.5)	4.00 (101.6)	10.25 (260.4)	3.50 (88.9)	5.50 (139.7)	7.00 (177.8)	7.62 (193)	10.49 (266)	5.63 (143)	3.0 (76.1)	2.0 (51.6)	3.94 (100)	8.66 (220)	3.03 (77)	
	145TC		5.00 (127)													
	182TC	4.37 (111)	4.50 (114.3)	11.37 (288.8)	4.50 (114.3)	7.50 (190.5)	8.00 (203.2)	8.69 (221)	11.57 (294)	6.65 (169)						
	184TC		5.50 (139.7)													
	213TC	5.38 (136.7)	5.50 (139.7)	13.88 (352.6)	5.25 (133.4)	8.50 (215.9)	8.75 (222.3)	8.55 (217)	11.42 (290)							
	215TC		7.0 (177.8)													
	254TC	6.50 (165.1)	8.25 (209.6)	18.00 (457.2)	6.25 (158.8)	10.00 (254)	9.75 (267.7)	8.56 (217)	11.42 (290)	7.28 (185)						
	256TC		10.00 (254)													
	284TSC	6.50 (165.1)	9.50 (241.3)	19.00 (482.6)	7.00 (177.8)	11.00 (279.4)	10.50 (266.7)	7.89 (201)	10.79 (274)	6.61 (168)						
	286TSC		11.00 (279.4)													
	324TSC	7.00 (177.8)	10.50 (266.7)	20.50 (520.7)	8.00 (203.2)	12.50 (317.5)	11.50 (292.1)	8.96 (227)	11.81 (300)	7.68 (195)						
326TSC		12.00 (304.8)														
W+60/110	182TC	4.37 (111)	4.50 (114.3)	11.37 (288.8)	4.50 (114.3)	7.50 (190.5)	8.00 (203.2)	8.45 (215)	13.45 (342)	6.77 (172)	4.0 (102)	3.0 (76.1)	4.17 (106)	11.42 (290)	2.68 (68)	
	184TC		5.50 (139.7)													
	213TC	5.38 (136.7)	5.50 (139.7)	13.88 (352.6)	5.25 (133.4)	8.50 (215.9)	8.75 (222.3)	8.32 (211)	13.32 (338)							
	215TC		7.0 (177.8)													
	254TC	6.50 (165.1)	8.25 (209.6)	18.00 (457.2)	6.25 (158.8)	10.00 (254)	9.75 (267.7)	8.33 (212)	13.33 (339)							7.40 (188)
	256TC		10.00 (254)													
	284TSC	6.50 (165.1)	9.50 (241.3)	19.00 (482.6)	7.00 (177.8)	11.00 (279.4)	10.50 (266.7)	7.70 (195)	12.70 (322)							6.77 (172)
	286TSC		11.00 (279.4)													
	324TSC	7.00 (177.8)	10.50 (266.7)	20.50 (520.7)	8.00 (203.2)	12.50 (317.5)	11.50 (292.1)	8.76 (222)	13.76 (349)							7.84 (199)
326TSC		12.00 (304.8)														
W+65/350	213TC	5.38 (136.7)	5.50 (139.7)	13.88 (352.6)	5.25 (133.4)	8.50 (215.9)	8.75 (222.3)	8.80 (223)	15.04 (382)	6.18 (157)	6.06 (154) DN150	4.09 (104) DN100	4.21 (107)	10.63 (270)	3.74 (95)	
	215TC		7.0 (177.8)													
	254TC	6.50 (165.1)	8.25 (209.6)	18.00 (457.2)	6.25 (158.8)	10.00 (254)	9.75 (267.7)	8.80 (223)	15.04 (382)	6.81 (173)						
	256TC		10.00 (254)													
	284TSC	6.50 (165.1)	9.50 (241.3)	19.00 (482.6)	7.00 (177.8)	11.00 (279.4)	10.50 (266.7)	8.17 (208)	14.45 (367)	6.18 (157)						
	286TSC		11.00 (279.4)													
	324TSC	7.00 (177.8)	10.50 (266.7)	20.50 (520.7)	8.00 (203.2)	12.50 (317.5)	11.50 (292.1)	9.67 (246)	15.94 (405)							
	326TSC		12.00 (304.8)													
	364TSC	7.00 (177.8)	11.25 (285.8)	20.50 (520.7)	9.00 (228.6)	14.00 (355.6)	12.50 (317.5)	8.68 (220)	14.94 (379)	7.68 (195)						
	365TSC		12.25 (311.2)													
405TSC	-----	13.75 (349.3)	-----	10.000 (254)	16.00 (406.4)	13.50 (342.9)	-----	-----								

Tolerances:	Y: +0" -0.197"	X: +0.197" -0"	OL,ZZ: nominal	B: ±0.197"	L: ±0.197"	Others: ±0.079"
-------------	-------------------	-------------------	----------------	------------	------------	-----------------



7. W+ Spare Parts, Dimensions

7.1 Pump Dimensions

Pump Type	Motor Size	F1	F2	F3	D	A	E	L	L W+	B	ZZ	OL	Z	X (Butt weld)	Y (Butt weld)
W+70/40	143TC	3.75	4.00 (101.6)	10.25 (260.4)	3.50 (88.9)	5.50 (139.7)	7.00 (177.8)	7.58 (193)	10.27 (261)	6.46 (164)	2.5 (64)	1.5 (38.6)	5.08 (129)	8.86 (225)	2.17 (55)
	145TC	(93.5)	5.00 (127)												
	182TC	4.37 (111)	4.50 (114.3)	11.37 (288.8)	4.50 (114.3)	7.50 (190.5)	8.00 (203.2)	8.57 (218)	11.26 (286)	7.40 (188)					
	184TC		5.50 (139.7)												
	213TC	5.38 (136.7)	5.50 (139.7)	13.88 (352.6)	5.25 (133.4)	8.50 (215.9)	8.75 (222.3)	8.44 (214)	11.10 (282)						
	215TC		7.0 (177.8)												
	254TC	6.50 (165.1)	8.25 (209.6)	18.00 (457.2)	6.25 (158.8)	10.00 (254)	9.75 (267.7)	8.45 (215)	11.14 (283)	8.03 (204)					
	256TC		10.00 (254)												
	284TSC	6.50 (165.1)	9.50 (241.3)	19.00 (482.6)	7.00 (177.8)	11.00 (279.4)	10.50 (266.7)	7.82 (198)	10.47 (266)	7.40 (188)					
	286TSC		11.00 (279.4)												
	324TSC	7.00 (177.8)	10.50 (266.7)	20.50 (520.7)	8.00 (203.2)	12.50 (317.5)	11.50 (292.1)	8.92 (226)	11.57 (294)	8.50 (216)					
	326TSC		12.00 (304.8)												
W+80/80	182TC	4.37 (111)	4.50 (114.3)	11.37 (288.8)	4.50 (114.3)	7.50 (190.5)	8.00 (203.2)	8.96 (228)	11.65 (296)	7.20 (183)	3.0 (76.6)	2.0 (51.8)	5.670 (144)	10.08 (256)	2.76 (70)
	184TC		5.50 (139.7)												
	213TC	5.38 (136.7)	5.50 (139.7)	13.88 (352.6)	5.25 (133.4)	8.50 (215.9)	8.75 (222.3)	8.83 (224)	11.50 (292)						
	215TC		7.0 (177.8)												
	254TC	6.50 (165.1)	8.25 (209.6)	18.00 (457.2)	6.25 (158.8)	10.00 (254)	9.75 (267.7)	8.84 (224)	11.50 (292)	7.84 (199)					
	256TC		10.00 (254)												
	284TSC	6.50 (165.1)	9.50 (241.3)	19.00 (482.6)	7.00 (177.8)	11.00 (279.4)	10.50 (266.7)	8.21 (208)	10.87 (276)	7.20 (183)					
	286TSC		11.00 (279.4)												
	324TSC	7.00 (177.8)	10.50 (266.7)	20.50 (520.7)	8.00 (203.2)	12.50 (317.5)	11.50 (292.1)	9.59 (243)	12.24 (311)						
	326TSC		12.00 (304.8)												
	364TSC	7.00 (177.8)	11.25 (285.8)	20.50 (520.7)	9.00 (228.6)	14.00 (355.6)	12.50 (317.5)	10.22 (260)	12.90 (328)	8.58 (218)					
	365TSC		12.25 (311.2)												
405TSC	-----	13.75 (349.3)	-----	10.000 (254)	16.00 (406.4)	13.50 (342.9)	-----	-----							
W+110/130	213TC	5.38 (136.7)	5.50 (139.7)	13.88 (352.6)	5.25 (133.4)	8.50 (215.9)	8.75 (222.3)	9.03 (229)	13.35 (339)	6.93 (176)	4.0 (102)	3.0 (76.2)	6.18 (157)	9.06 (230)	3.23 (82)
	215TC		7.0 (177.8)												
	254TC	6.50 (165.1)	8.25 (209.6)	18.00 (457.2)	6.25 (158.8)	10.00 (254)	9.75 (267.7)	9.04 (229)	13.35 (339)	7.56 (192)					
	256TC		10.00 (254)												
	284TSC	6.50 (165.1)	9.50 (241.3)	19.00 (482.6)	7.00 (177.8)	11.00 (279.4)	10.50 (266.7)	8.41 (213)	12.72 (323)	6.93 (176)					
	286TSC		11.00 (279.4)												
	324TSC	7.00 (177.8)	10.50 (266.7)	20.50 (520.7)	8.00 (203.2)	12.50 (317.5)	11.50 (292.1)	10.06 (255)	14.37 (365)						
	326TSC		12.00 (304.8)												
	364TSC	7.00 (177.8)	11.25 (285.8)	20.50 (520.7)	9.00 (228.6)	14.00 (355.6)	12.50 (317.5)	10.69 (271)	15.02 (381)	8.58 (218)					
	365TSC		12.25 (311.2)												
	405TSC	-----	13.75 (349.3)	-----	10.000 (254)	16.00 (406.4)	13.50 (342.9)	-----	-----						

Tolerances:	Y: +0" / -0.197"	X: +0.197" / -0"	OL,ZZ: nominal	B: ±0.197"	L: ±0.197"	Others: ±0.079"
-------------	------------------	------------------	----------------	------------	------------	-----------------



7. W+ Spare Parts, Dimensions

7.2 Pump Parts

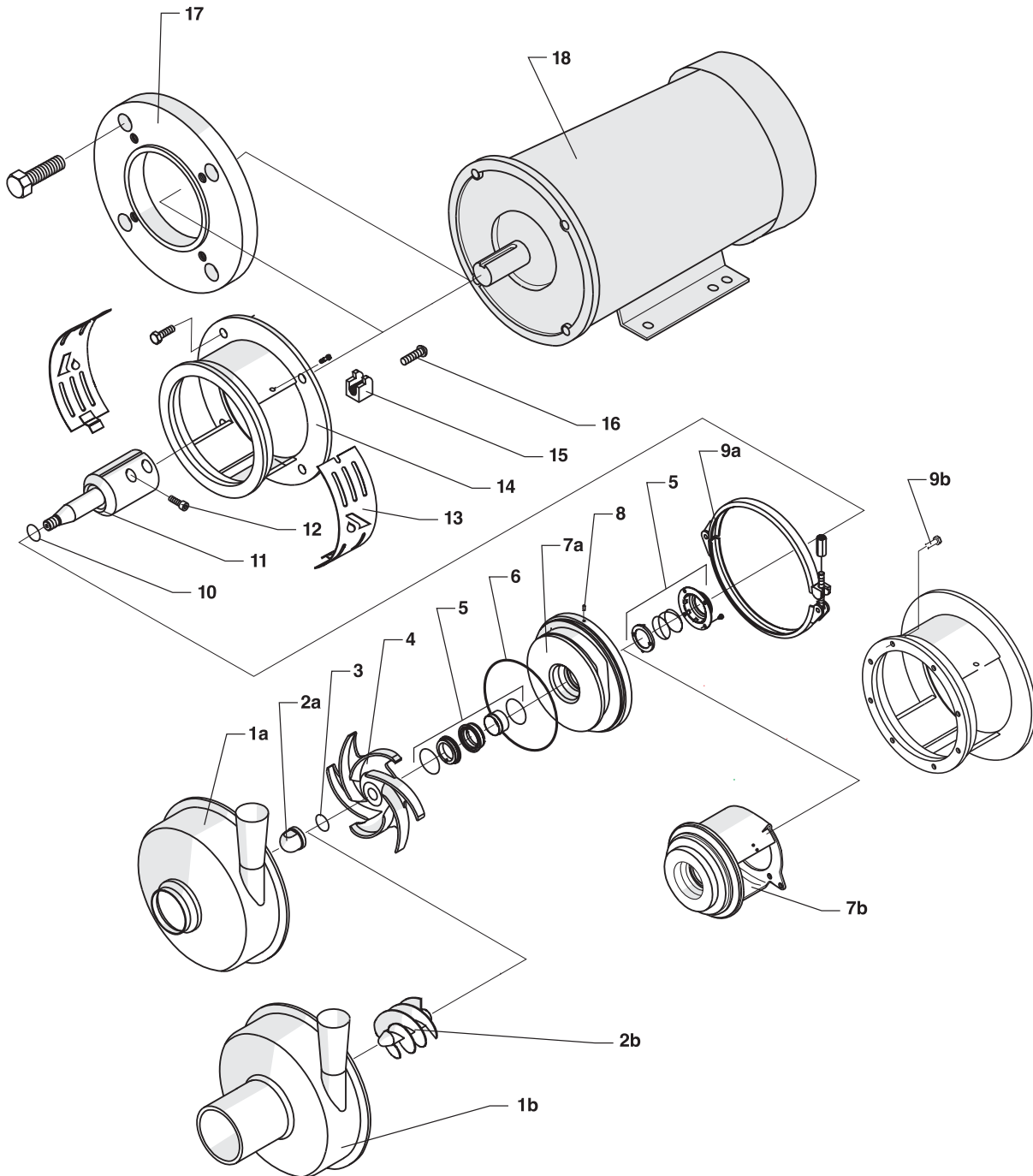



7. W+ Spare Parts, Dimensions

7.2 Pump Parts

Pos	Qty	Description	Part Number by Pump Type							
			W+10/8	W+22/20	W+30/80	W+25/210	W+35/35	W+35/55	W+30/120	W+50/600
1a	1	Pump casing	L273901	L182511	L268510	L253430	L268511	L268512	L268513	
1b	1	Inducer casing	-----	L188600	L188601	L188611	L188602	L188603	L188604	
2a	1	Cap nut	L274383	L274213	L274213	L274214	L274213	L274213	L274214	
2b	1	Inducer	-----	L188248	L188250	L182698	L188248	L188250	L188252	
3	1	O-ring	see page 29							
4	1	Impeller	see page 26/27							
5	1	Shaft seal	see page 28							
6	1	O-ring	see page 29							
7a	1	Back flange	-----	-----	L260949	L260959	L260950	L260951	L260952	
7b	1	Back flange	N/A*	N/A*	-----	-----	-----	-----	-----	
8	1	Pin	-----	-----	L772493	-----	L772493	L772493	L772493	
9a	1	Clamp ring	L169050	L188430	L188436	-----	L188436	L188436	L188432	
9b	8	Screw	-----	-----	-----	L756001	-----	-----	-----	
10	1	O-ring	see page 29							
11	1	Shaft	see page 32							
12	2	Screw	see page 32							
13	2	Shaft guard	see page 33/34							
14	1	Motor adapter	see page 33/34							
15	2	Bracket or screw	-----	-----	L268499	L771199	L268499	L268499	L268499	-----
16	2	Screw	-----	-----	L701942	L701509	L701942	L701942	L701942	-----
16	4	Screw	-----	-----	-----	-----	-----	-----	-----	L701686
17	1	Flange	see page 33							
18	1	Motor	see order							
--	--	Frame	see page 35							

Pos	Qty	Description	W+50/8	W+55/35	W+55/60	W+60/110	W+65/350	W+70/40	W+80/80	W+110/130
1a	1	Pump housing	L273902	L268514	L268515	L268516	L253431	L268517	L268518	L253429
1b	1	Inducer housing	-----	L188605	L188606	L188607	L188612	L188608	L188609	L188610
2a	1	Cap nut	L274383	L274213	L274214	L274214	L274214	L274214	L274214	L274214
2b	1	Inducer	-----	L188248	L188251	L188252	L182698	L188249	L188251	L188252
3	1	O-ring	see page 29							
4	1	Impeller	see page 26/27							
5	1	Shaft seal	see page 29							
6	1	O-ring	see page 29							
7a	1	Back flange	L260961	L260953	L260954	L260955	L260960	L260956	L260957	L260958
8	1	Pin	-----	L772493	L772493	L772493	-----	L772493	L772493	-----
9a	1	Clamp ring	L188431	L188432	L188432	L188433	-----	L188434	L188435	-----
9b	8	Screw	-----	-----	-----	-----	L700234	-----	-----	L701669
10	1	O-ring	see page 29							
11	1	Shaft	see page 32							
12	2	Screw	see page 32							
13	2	Shaft guard	see page 33/34							
14	1	Motor adapter	see page 33/34							
15	2	Bracket or screw	L268499	L268499	L268499	L268499	L700241	L268499	L268499	L701686
16	2	Screw	L701942	L701942	L701942	L701942	L234177	L701942	L701942	L701669
17	1	Flange	see page 33							
18	1	Motor	see order							
--	--	Frame	see page 35							

* integrated in motor adapter pos. 14



7. W+ Spare Parts, Dimensions

7.3 Impeller

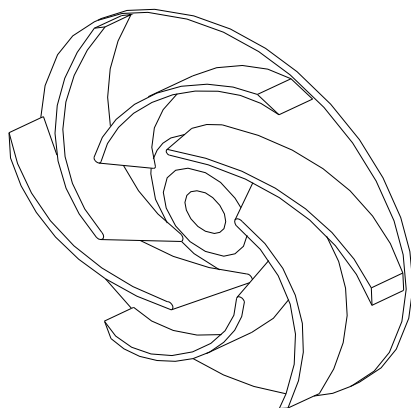

Impeller Ø Semi-Closed	Pump Type				
	W+22/20	W+30/80	W+35/35	W+35/55	W+50/8
	Part No.				
7.9" / Ø200					L267352
7.7" / Ø195					L273903
7.5" / Ø190					L273904
7.3" / Ø185					L273905
7.1" / Ø180				L253751	L273906
6.9" / Ø175			L267000	L253752	L273907
6.7" / Ø170		L261221	L267001	L253753	L273908
6.5" / Ø165		L261222	L267002	L253754	L273909
6.3" / Ø160		L261223	L267003	L253755	L273910
6.1" / Ø155		L261224	L267004	L253756	L273911
5.9" / Ø150		L261225	L267005	L253757	L273912
5.7" / Ø145		L261226	L267006	L253758	L273913
5.5" / Ø140	L253767*	L261227	L267007	L253759	L273914
5.3" / Ø135	L253768	L261228	L267008	L253760	
5.1" / Ø130	L253769	L261229	L267009	L253761	
4.9" / Ø125	L253770	L261230	L267010	L253762	
4.7" / Ø120	L253771	L261231	L267011	L253763	
4.5" / Ø115	L253772	L261232			
4.3" / Ø110	L253773	L261233			
4.1" / Ø105	L253774				
3.9" / Ø100	L253775				
3.7" / Ø95	L253776				

* 5.6" / Ø142

Star/impeller gauge (not shown)	
Part No.	Size
L274534	4.5" / 115 mm
L259776	5.9" / 150 mm
L260406	9.1" / 230 mm
L267637	11" / 280 mm

7. W+ Spare Parts, Dimensions

7.3 Impeller

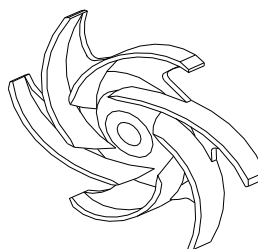

Impeller Ø open	Pump type									
	W+10/8	W+30/120	W+55/35	W+55/60	W+60/110	W+70/40	W+80/80	W+110/130	W+25/210	W+65/350
	Part No.									
11.4" / Ø290								L267057	L267076	
11.2" / Ø285								L267058	L267077	
11.0" / Ø280								L267059	L267078	
10.8" / Ø275								L267060	L267079	
10.6" / Ø270								L267061	L267080	
10.4" / Ø265								L267062	L267081	
10.2" / Ø260								L267063	L267082	L267100
10.0" / Ø255							L267044	L267064	L267083	L267101
9.8" / Ø250							L267045	L267065	L267084	L267102
9.6" / Ø245							L267046	L267066	L267085	L267103
9.4" / Ø240						L267033	L267047	L267067	L267086	L267104
9.3" / Ø235						L267034	L267048	L267068	L267087	L267105
9.1" / Ø230					L267115	L267035	L267049	L267069	L267088	L267106
8.9" / Ø225					L267116	L267036	L267050	L267070	L267089	L267107
8.7" / Ø220				L253777	L267117	L267037	L267051	L267071	L267090	L267108
8.5" / Ø215				L253778	L267118	L267038	L267052	L267072	L267091	L267109
8.3" / Ø210			L267021	L253779	L267119	L267039	L267053	L267073	L267092	L267110
8.1" / Ø205			L267022	L253780	L267120	L267040	L267054	L267074		L267111
7.9" / Ø200			L267023	L253781	L267121	L267041	L267055	L267075		L267112
7.7" / Ø195			L267024	L253782	L267122	L267042	L267056			L267113
7.5" / Ø190			L267025	L253783	L267123	L267043				L267114
7.3" / Ø185			L267026	L253784	L267124					
7.1" / Ø180			L267027	L253785	L267125					
6.9" / Ø175		L267012	L267028	L253786	L267126					
6.7" / Ø170		L267013	L267029	L253787	L267127					
6.5" / Ø165		L267014	L267030	L253788	L267128					
6.3" / Ø160		L267015	L267031	L253789	L267129					
6.1" / Ø155		L267016	L267032							
5.9" / Ø150		L267017								
5.7" / Ø145		L267018								
5.5" / Ø140		L267019								
5.3" / Ø135		L267020								
4.3" / Ø110	L267347									
4.1" / Ø105	L267348									
3.9" / Ø100	L267349									
3.7" / Ø95	L267350									
3.5" / Ø90	L267351									



7. W+ Spare Parts, Dimensions

7.4 Shaft Seal

7.4.1 Fixing Kit

A. Single Seal Ø25+Ø35

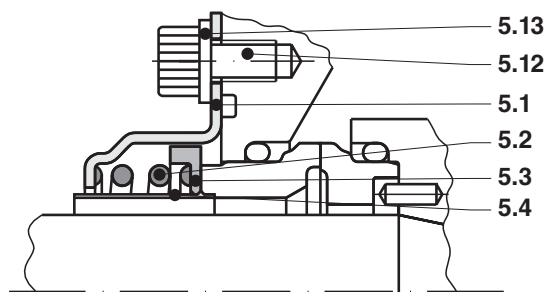

B. Double Seal Ø25+Ø35

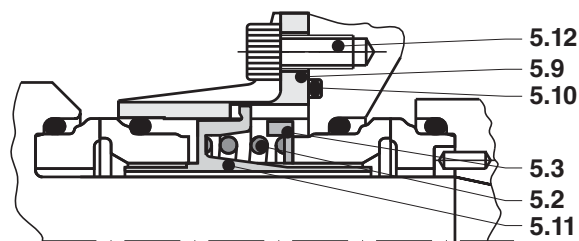

Fixing Kit				Shaft Size	
Pos	Description	Items	Material	Ø25 Part No.	Ø35 Part No.
A	Single Seal	Complete	-----	L772460	L772465
		Pos 5.1 Seal housing	AISI 316		
		Pos 5.2 Spring	AISI 316		
		Pos 5.3 Pressure ring	AISI 316		
B	Double Seal	Complete	-----	L194448	L194449
		Pos 5.2 Spring	AISI 316		
		Pos 5.3 Pressure ring	AISI 316		
		Pos 5.9 Seal housing	AISI 316		
		Pos 5.11 Pressure ring	AISI 316		

Shaft Size	
Ø25	Ø35
Pump type	
W+10/8	W+25/210
W+22/20	W+30/120
W+30/80	W+55/60
W+35/35	W+60/110
W+35/55	W+65/350
W+50/8	W+70/40
W+55/35	W+80/80
	W+110/130

5.10		O-ring	EPDM	L772470	L771362
5.12		4 Screws M6x10	AISI 316	L770496	L770496
5.13	only W+50/8	4 Washer M6	AISI 316	L701477	-----
5.14		4 Screws M8x30	AISI 316	-----	-----
5.15		4 Screws M8x50	AISI 316	-----	-----

7. W+ Spare Parts, Dimensions

7.4.2 Face Kit

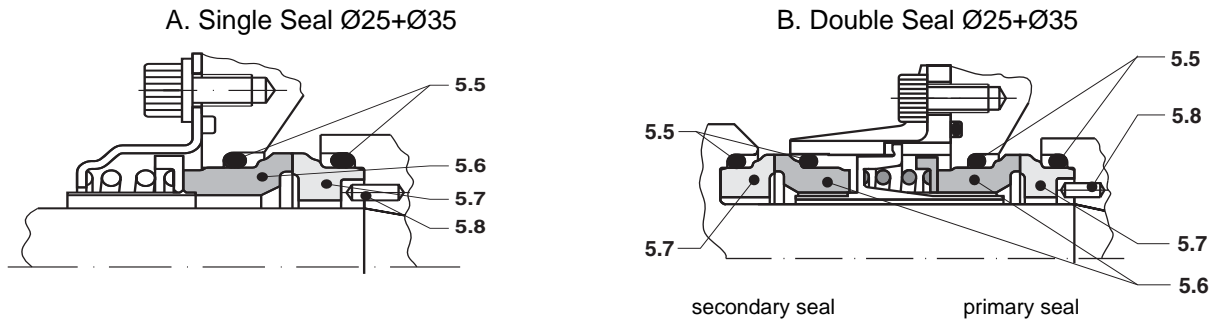

Shaft Seal				Shaft Size	
				Ø25	Ø35
Pos	Description	Items	Material	Part No.	
A	Face Kit SiC/Car EPDM	Complete Pos 5.5 2 off O-rings Pos 5.6 Stationary seal Pos 5.7 Rotary seal Pos 5.8 Pin	EPDM Car SiC AISI316L	L772461	L772466
B					
A	Face Kit SiC/Car FPM (Viton)	Complete Pos 5.5 2 off O-rings Pos 5.6 Stationary seal Pos 5.7 Rotary seal Pos 5.8 Pin	FPM (Viton) Car SiC AISI316L	L772462	L772467
B					
A	Face Kit SiC/SiC EPDM	Complete Pos 5.5 2 off O-rings Pos 5.6 Stationary seal Pos 5.7 Rotary seal Pos 5.8 Pin	EPDM SiC SiC AISI316L	L772463	L772468
B					
A	Face Kit SiC/SiC FPM (Viton)	Complete Pos 5.5 2 off O-rings Pos 5.6 Stationary seal Pos 5.7 Rotary seal Pos 5.8 pin	FPM (Viton) SiC SiC AISI316L	L772464	L772469
B					



7. W+ Spare Parts, Dimensions

7.5 Seal Kit

Single Seal

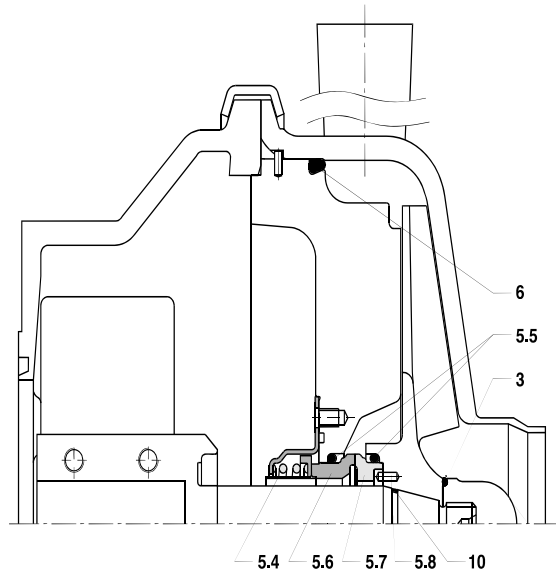

Double Seal

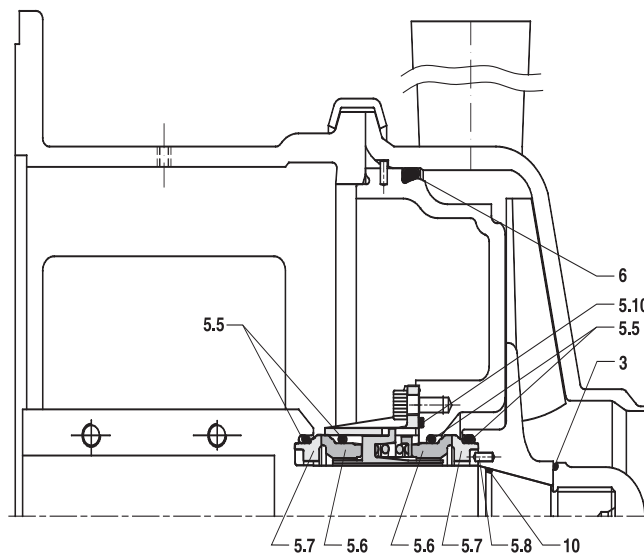



7. W+ Spare Parts, Dimensions

Seal Kit , Single		Pump Type							
		W+10/8	W+22/20	W+30/80	W+25/210	W+35/35	W+35/55	W+30/120	
Pos.	Material	Part No.							
3, 6, 10, 5.4, 5.5, 5.6, 5.7, 5.8	SiC/SiC - EPDM	L800875	L800800	L800801	L800802	L800801	L800801	L800807	
	SiC/Car - EPDM	L800877	L800915	L800916	L800917	L800916	L800916	L800922	
	SiC/SiC - FPM	L800871	L800813	L800814	L800815	L800814	L800814	L800820	
	SiC/Car - FPM	L800873	L800928	L800929	L800930	L800929	L800929	L800935	
		W+50/8	W+55/35	W+55/60	W+60/110	W+65/350	W+70/40	W+80/80	W+110/130
3, 6, 10, 5.4, 5.5, 5.6, 5.7, 5.8	SiC/SiC - EPDM	L800876	L800806	L800807	L800808	L800809	L800810	L800811	L800812
	SiC/Car - EPDM	L800878	L800921	L800922	L800923	L800924	L800925	L800926	L800927
	SiC/SiC - FPM	L800872	L800819	L800820	L800821	L800822	L800823	L800824	L800825
	SiC/Car - FPM	L800874	L800934	L800935	L800936	L800937	L800938	L800939	L800940

Seal Kit , Double		Pump Type							
		W+10/8	W+22/20	W+30/80	W+25/210	W+35/35	W+35/55	W+30/120	
Pos.	Material	Part No.							
3, 6, 10, 4x 5.5, 2x 5.6, 2x 5.7, 5.8, 5.10	SiC/SiC - SiC/Car EPDM	L808560	L808561	L808563	L808562	L808563	L808563	L808568	
	SiC/Car - SiC/Car EPDM	L808574	L808575	L808577	L808576	L808577	L808577	L808582	
	SiC/SiC - SiC/Car FPM	L808588	L808589	L808591	L808590	L808591	L808591	L808596	
	SiC/Car - SiC/Car FPM	L808602	L808603	L808605	L808604	L808605	L808605	L808610	
		W+50/8	W+55/35	W+55/60	W+60/110	W+65/350	W+70/40	W+80/80	W+110/130
3, 6, 10, 4x 5.5, 2x 5.6, 2x 5.7, 5.8, 5.10	SiC/SiC - SiC/Car EPDM	L808566	L808567	L808568	L808569	L808570	L808571	L808572	L808573
	SiC/Car - SiC/Car EPDM	L808580	L808581	L808582	L808583	L808584	L808585	L808586	L808587
	SiC/SiC - SiC/Car FPM	L808594	L808595	L808596	L808597	L808598	L808599	L808600	L808601
	SiC/Car - SiC/Car FPM	L808608	L808609	L808610	L808611	L808612	L808613	L808614	L808615

Seal Kit , Double, Self-Sintered SiC		Pump Type							
		W+10/8	W+22/20	W+30/80	W+25/210	W+35/35	W+35/55	W+30/120	
Pos.	Material	Part No.							
3, 6, 10, 4x 5.5, 2x 5.6, 2x 5.7, 5.8, 5.10	SiC/SiC - SiC/Car EPDM	L888560	L888561	L888563	L888562	L888563	L888563	L888568	
	SiC/Car - SiC/Car EPDM	L888574	L888575	L888577	L888576	L888577	L888577	L888582	
	SiC/SiC - SiC/Car FPM	L888588	L888589	L888591	L888590	L888591	L888591	L888596	
	SiC/Car - SiC/Car FPM	L888602	L888603	L888605	L888604	L888605	L888605	L888610	
		W+50/8	W+55/35	W+55/60	W+60/110	W+65/350	W+70/40	W+80/80	W+110/130
3, 6, 10, 4x 5.5, 2x 5.6, 2x 5.7, 5.8, 5.10	SiC/SiC - SiC/Car EPDM	L888566	L888567	L888568	L888569	L888570	L888571	L888572	L888573
	SiC/Car - SiC/Car EPDM	L888580	L888581	L888582	L888583	L888584	L888585	L888586	L888587
	SiC/SiC - SiC/Car FPM	L888594	L888595	L888596	L888597	L888598	L888599	L888600	L888601
	SiC/Car - SiC/Car FPM	L888608	L888609	L888610	L888611	L888612	L888613	L888614	L888615

Seal Kit , O-rings		Pump Type							
		W+10/8	W+22/20	W+30/80	W+25/210	W+35/35	W+35/55	W+30/120	
Pos.	Material	Part No.							
3, 6, 10	EPDM	L808760	L808761	L808762	L808763	L808762	L808762	L808765	
	FPM (Viton)	L808774	L808775	L808776	L808777	L808776	L808776	L808779	
		W+50/8	W+55/35	W+55/60	W+60/110	W+65/350	W+70/40	W+80/80	W+110/130
3, 6, 10	EPDM	L808766	L808767	L808765	L808769	L808770	L808771	L808772	L808773
	FPM (Viton)	L808780	L808781	L808779	L808783	L808784	L808785	L808786	L808787



7. W+ Spare Parts, Dimensions

7.6 Shaft

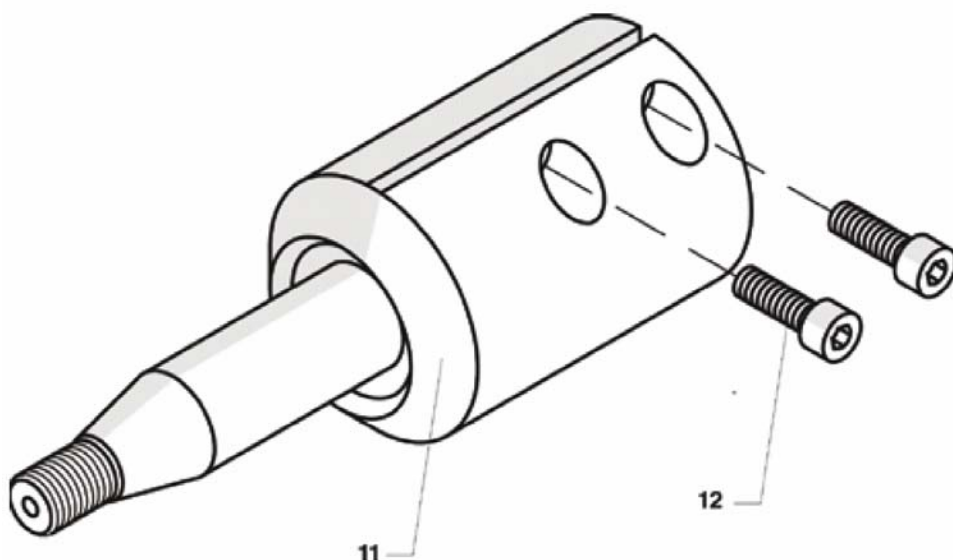

Motor Frame Size					
Pump Type	56C	143-145TC	182-184TC	213-215TC	254-256TC
Pos. 11, Shaft Ø25					
W+10/8	L267353	L267354	-----	-----	-----
W+22/20	L267332	L267333	L267334	L267335	-----
W+30/80	-----	L267333	L267334	L267335	L267336
W+35/35	L267332	L267333	L267334	L267335	L267336
W+35/55	L267332	L267333	L267334	L267335	L267336
W+50/8	-----	L267354	L267355	L267356	-----
W+55/35	L267332	L267333	L267334	L267335	L267336
Pos. 12, Screw/Bolt, Qty 2 per shaft					
	L701942	L771199	L771199	135664+	135664+

Pump Type	Motor Frame Size							
	143-145TC	182-184TC	213-215TC	254-256TC	284-286TSC	324-326TSC	364-365TSC	405TSC
Pos. 11, Shaft Ø35								
W+25/210	-----	-----	-----	-----	L267342	L267343	L267343	-----
W+30/120	L267338	L267339	L267340	L267341	L267342	L267343	-----	-----
W+55/60	L267338	L267339	L267340	L267341	L267342	L267343	-----	-----
W+60/110	-----	L267339	L267340	L267341	L267342	L267343	L267343	-----
W+65/350	-----	-----	L267340	L267341	L267342	L267343	L267343	L267357
W+70/40	L267338	L267339	L267340	L267341	L267342	L267343	-----	-----
W+80/80	-----	L267339	L267340	L267341	L267342	L267343	L267343	L267357
W+110/130	-----	-----	L267340	L267341	L267342	L267343	L267343	L267357
Pos. 12, Screw/Bolt, Qty 2 per shaft								
	L771199	L771199	L771199	135664+	135664+	135664+	135664+	135664+

Note:

- As of April 2014, the screws used on stub shafts L267335, L267336, L267341, L267342, and L267356 changed from M8 (22 lb-ft torque) to M10 (41 lb-ft torque).

7. W+ Spare Parts, Dimensions

7.7 Motor Adapter and Shaft Guard

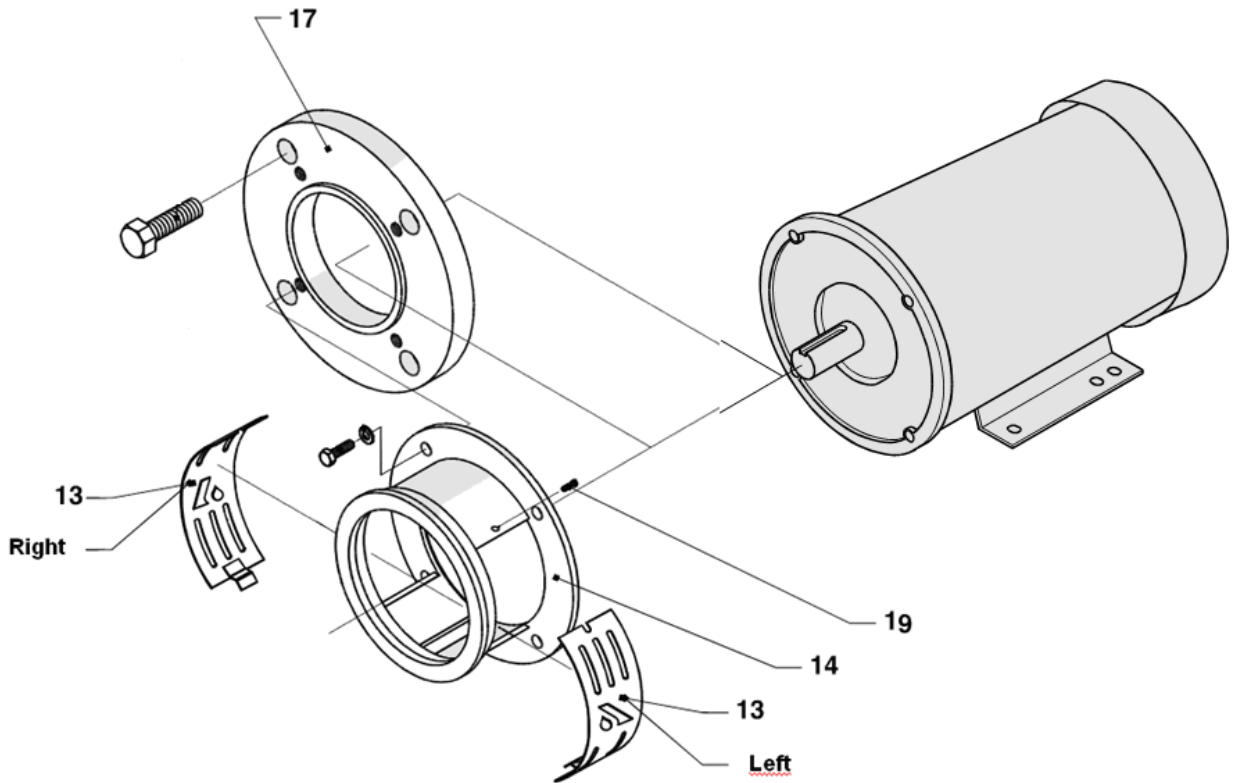

Pump Type	Motor								
	56C	143-145TC	182-184TC	213-215TC	254-256TC**	284-286TSC	324-326TSC	364-365TSC	405TSC
	Pos. 14 Motor Adapter								
W+10/8	L273976#	L273976#	-----	-----	-----	-----	-----	-----	-----
W+22/20	L260973#	L260973#	L260973#*	L260973#*	-----	-----	-----	-----	-----
W+30/80	L260974	L260974	L260975	L260975	L260975	-----	-----	-----	-----
W+25/210	-----	-----	-----	L168688	L168688	L168689	L168690	L168690	-----
W+35/35	L260974	L260974	L260975	L260975	L260975	-----	-----	-----	-----
W+35/55	L260974	L260974	L260975	L260975	L260975	-----	-----	-----	-----
W+30/120	-----	L260976	L260977	L260977	L260977	L260978	L260978***	-----	-----
W+50/8	-----	L267363	L267364	L267364	-----	-----	-----	-----	-----
W+55/35	L260976	L260976	L260977	L260977	L260977	-----	-----	-----	-----
W+55/60	-----	L260976	L260977	L260977	L260977	L260978	L260978***	-----	-----
W+60/110	-----	-----	L260979	L260979	L260979	L260980	L260980***	L260980***	-----
W+65/350	-----	-----	-----	L168691	L168691	L168692	L168693	L168693	L168693
W+70/40	-----	L260982	L168680	L168680	L168680	L168681	L168681***	-----	-----
W+80/80	-----	-----	L260981	L260981	L260981	L168683	L168682	L168682	L168682
W+110/130	-----	-----	-----	L168684	L168684	L168685	L168686	L168686	L168686

integrated in back plate pos. 7b

	Pos. 17 Flange Adapter								
*	-----	-----	L267095	L267095	-----	-----	-----	-----	-----
**	-----	-----	-----	-----	L267096	-----	-----	-----	-----
***	-----	-----	-----	-----	-----	-----	L267097	L267097	-----



7. W+ Spare Parts, Dimensions

7.7 Motor Adapter and Shaft Guard

Pump Type	Qty	Motor								
		56C	143-145TC	182-184TC	213-215TC	254-256TC	284-286TSC	324-326TSC	364-365TSC	405TSC
		Pos. 13 Shaft Guard								
W+10/8	2 R/L	L188815	L188815							
W+22/20	2 R/L	L188334	L188334	L188334	L188334					
W+30/80 W+35/35 W+35/55	1 R	L188333	L188333							
	1 L	L188285	L188285							
	2 R/L			L188653	L188653	L188653				
W+25/210	2 R/L				L279838	L279838	L188814	L188814	L188814	
W+30/120	1 R		L188339							
	1 L		L188597							
	2 R/L			L188653	L188653	L188653	L188811	L188811		
W+50/8	1 R		L188339							
	1 L		L188597							
	2 R/L			L188653	L188653					
W+55/35	1 R	L188339	L188339							
	1 L	L188597	L188597							
	2 R/L			L188653	L188653	L188653				
W+55/60	1 R		L188339							
	1 L		L188597							
	2 R/L			L188653	L188653	L188653	L188811	L188811		
W+60/110	1 R			L188819	L188819	L188819				
	1 L			L188822	L188822	L188822				
	2 R/L						L188816	L188816	L188816	
W+65/350	2 R/L				L188653	L188653	L188653	L188817	L188817	L188817
W+70/40	1 R		L188284	L188827	L188827	L188827				
	1 L		L188283	L188828	L188828	L188828				
	2 R/L						L188825	L188825		
W+80/80	1 R			L804738	L804738	L804738	L804753	L188823	L188823	L188823
	1 L			L804739	L804739	L804739	L188826	L188824	L188824	L188824
	2 R/L									
W+110/130	2 R/L				L188653	L188653	L188811	L188812	L188812	L188812

Pos	Qty.	Motor								
		56C	143-145TC	182-184TC	213-215TC	254-256TC	284-286TSC	324-326TSC	364-365TSC	405TSC
		Part No.								
19	2	L700420	L700420	L700420	L700420	L700420	L700420	L700420	L700420	L700420

7. W+ Spare Parts, Dimensions

7.8 Frame

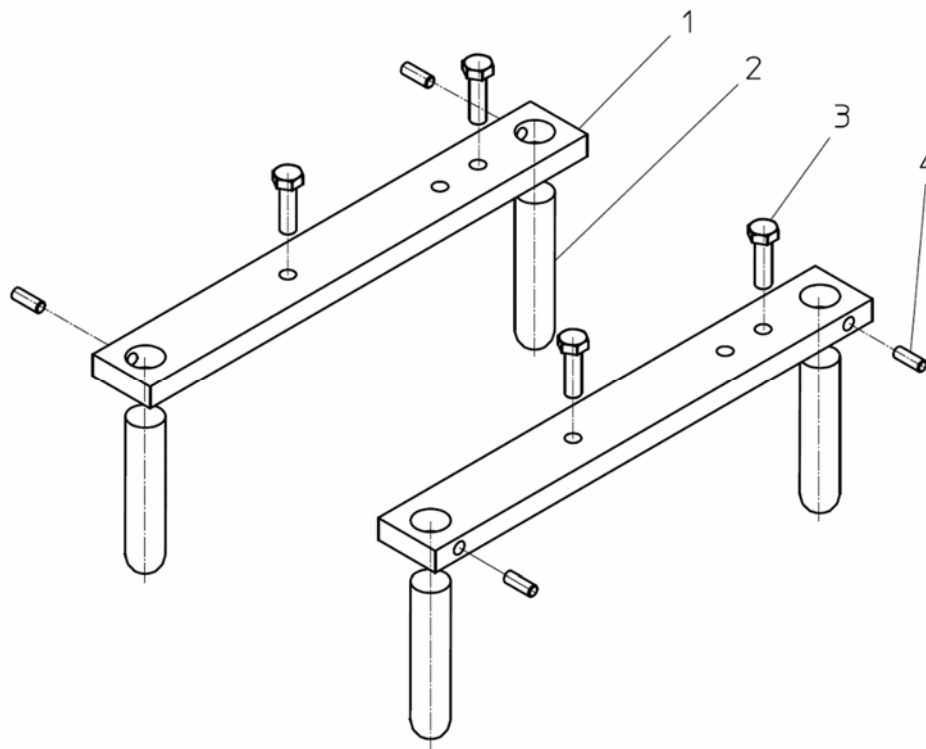

Pos	Qty	Description	Motor							405TSC	
			56C	143-145TC	182-184TC	213-215TC	254-256TC	284-286TSC	324-326TSC		364-365TSC
			Part No.								
--	--	Frame cpl.	L114365	L110256	L110255	L110254	L110253	L110252	L110251	L110251A	
1	2	Side bar	L114364	L110262	L110261	L110260	L110259	L110258	L110257	L110257A	
2	4	Leg 3/4"	L110264			-----					
2	4	Leg 1"	-----			L110263					
3	4	Screw	5/16-18 x 3/4		3/8-16 x 1		1/2-13 x 1 1/8		5/5-11 x 1 1/4		
4	2	Screw	1/4-20 x 1/2 SQ.HD			1/4-20 x 5/8 SQ.HD					



7. W+ Spare Parts, Dimensions

Notes

W+

CENTRIFUGAL PUMP

SPXFLOW



0508 4 BBENG

www.brownbros.co.nz

SPX FLOW, Inc.

611 Sugar Creek Road

Delavan, WI 53115

P: (262) 728-1900 or (800) 252-5200

F: (262) 728-4904 or (800) 252-5012

E: apvproductsspares@spxflow.com

SPX FLOW reserves the right to incorporate our latest design and material changes without notice or obligation.

Design features, materials of construction and dimensional data, as described in this bulletin, are provided for your information only and should not be relied upon unless confirmed in writing.

Please contact your local sales representative for product availability in your region. For more information visit www.spx.com.

The green ">" is a trademark of SPX FLOW, Inc.

ISSUED 07/2018

COPYRIGHT ©2018 SPX FLOW, Inc.