



XBGR Series

Installation, Operation and Maintenance Manual



Australia
Phone: 13 19 14
Email: enquiriesau@xylem.com
www.xylem.com/au

New Zealand
Phone: 0800 33 19 14
Email: enquiriesnz@xylem.com
www.xylem.com/nz



RCM
Compliant



AS4020 Certified
Suitable for
Drinking Water

XBGR Series

Installation, Operation and Maintenance Manual



CONGRATULATIONS!

You are now a proud owner of a quality Goulds Water Technology product. For best results, please read this instruction and Operation Manual (IOM) carefully before installing and using this product.

TABLE OF CONTENTS

Safety Precautions	2
General Information	3
Technical Data	3
Handling	4
Applications	4
Working Limits	4
Installation	4
Electrical Connection	4
Start Up	5
Maintenance	5
Safety Instructions	5
Wiring Diagram	5
Dimensional Specification	6
Trouble Shooting Guide	7
Goulds Pumps Limited Warranty	8

SAFETY PRECAUTIONS

This symbol    together with one of the following words "Danger" or "Warning" indicates the risk level deriving from failure to observe the prescribed safety precautions:

 **DANGER:** Risk of electrical shock. Warns that failure to observe the precautions involves a risk of electric shock.

 **DANGER:** Warns that failure to observe the precautions involves a risk of damage to persons and / or things.

 **WARNING:** Warns a failure to observe the precautions involves a risk of damaging the pump and / or the plant.

GENERAL INFORMATION

Close-coupled centrifugal jet pumps with built-in ejector system, designed to remain primed even in the presence of water-dissolved gases. The extensive use of stainless steel (AISI 304 or AISI 316) ensures a high performance, durable and lightweight pump.

TECHNICAL DATA

PUMP MODEL	P1 POWER (kw)	P2 POWER (kw)	SUCTION LIFT (m)	PIPE DIAM - INCH		FLOW Q	L/MIN M3/HR	5	15	20	30	40	50	60
				IN	OUT			0.3	0.9	1.2	1.8	2.4	3.0	3.6
XBGR050	0.55	0.37	8.5	1	1		HEAD (m)	31	25	23	19	14	9	-
XBGR075	0.75	0.55	8.5	1	1			34	29	23	21	19	16	13
XBGR100	1.04	0.75	8.5	1	1			38	32	-	25	22	19	13

In the Interest of technical development, Xylem reserves the right to modify specifications without notice.

Maximum Total Head

PUMP MODEL	MAXIMUM TOTAL HEAD
XBGR050	34m / 3.4 Bar
XBGR075	34m / 3.4 Bar
XBGR100	40m / 4.0 Bar

Maximum Inlet Water Pressure

PUMP MODEL	MAXIMUM INLET WATER PRESSURE
XBGR050	2.6 Bar
XBGR075	2.6 Bar
XBGR100	2.0 Bar

Maximum Operating Pressure

PUMP MODEL	MAXIMUM OPERATING PRESSURE
XBGR050	6 Bar
XBGR075	6 Bar
XBGR100	6 Bar

PROPER INSTALLATION FIG. 2

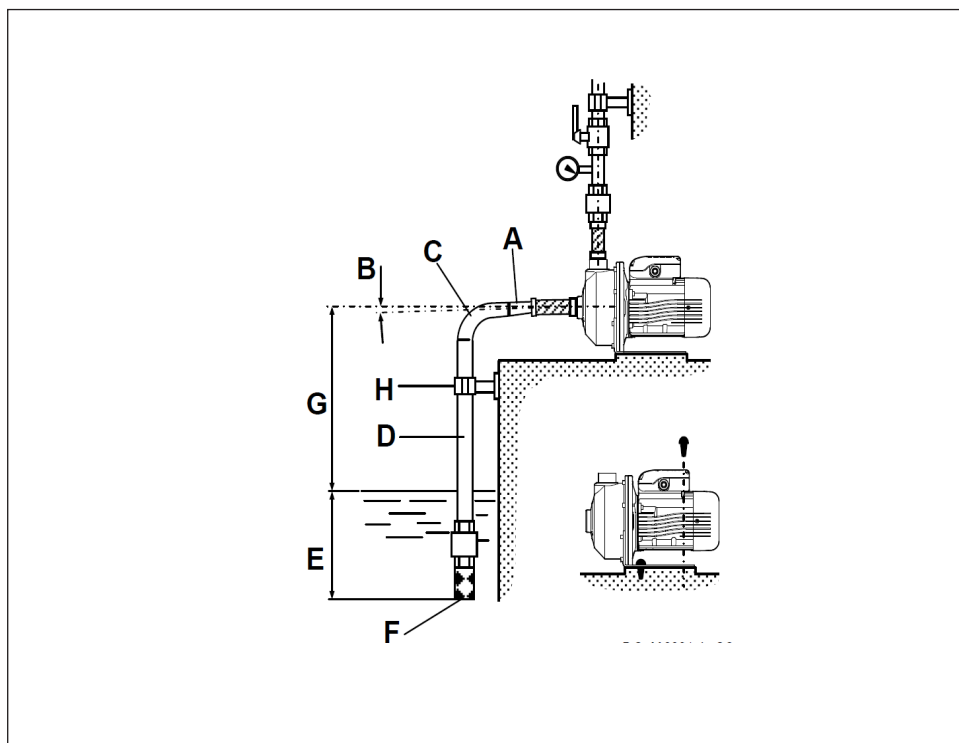

- A** Eccentric adapters
- B** Positive slope
- C** Wide bends
- D** Suction pipe diameter \geq pump port diameter
- E** Good immersion
- F** Foot valve (not necessary for XBGR series)
- G** Height difference in suction side
- H** Pipes must not exert stress on pump but on independent Supports.

1. HANDLING

The product must be lifted and handled with care.
Do not lift the pump by the power cable.

2. APPLICATIONS

The XBGR Series pump is designed to handle clean non-aggressive water free of dissolved gasses. The XBGR Series may be used in garden, irrigation and domestic applications where the pump is permanently installed. The XBGR Series is AS4020 certified suitable for drinking water applications.



AS4020 Certified
Suitable for
Drinking Water

3. OPERATING LIMITS

- ❗
- Max operating pressure: 6 Bar Max.
- Max Suction Lift: 8 to 9 m
- Ambient temperature: $\leq 40^{\circ}\text{C}$.
- Liquid temperature: $+5^{\circ}\text{C}$ to $+35^{\circ}\text{C}$.
- Max inlet pressure - See page 3

4. INSTALLATION

To install the pump, follow these Instructions

- a. The pump is designed for permanent installation only, detachable hose sets are not to be used.
- b. Mount the pumps securely to a stable foundation, utilising the mounting slots in the base.
- c. Place the pump as near as possible to the water supply.
- d. Do not submit the pump body to mechanical stress.
- e. The pump must be sheltered from weather elements (sun, rain & wind).
- f. For suction lift, always fit a foot valve with strainer on the suction pipe.
Both suction and discharge pipe must be well fastened.
- g. In case of suction lower than 4m, then the suction pipe diameter must always be bigger than the suction port.

See **Proper Installation fig. 2** - See page 3

5. ELECTRICAL CONNECTION

- ⚠ Make sure that the mains voltage and the reference characteristics (frequency, and Input current) correspond to the voltage specified as shown on the motor rating plate.
- ❗ The connections to the mains and grounding must be executed by qualified electrician and in compliance with local installation standards.
Carry out connections as per the diagram displayed on the underside of the terminal box lid.
- ⚠ The motor must be **absolutely grounded before any other operation**. The single phase model features a built-in thermal protector. For ambient temperatures of 40°C , supply cables with temperature characteristics of at least 95°C and minimum wire gauge of 1.5 mm^2 must be used.

6. START UP

- ❗ The XBGR Series is self-priming. Self-priming without the foot valve may require up to 3-4 minutes

7. MAINTENANCE

The pump should be serviced by qualified personnel only, after having been disconnected from the power.

8. SAFETY INSTRUCTIONS

 Pay attention to the working limits. Improper use may damage the pump and other property, may cause injury or death.

The pump is not suitable for use with flammable or dangerous liquids.

Make sure that the rated voltage and the mains voltage are compatible with the nameplate.

 Connect to the power mains using a multi-pole power switch with a switch-contact gap of at least 3mm. As additional protection from lethal electric shock, install a high-sensitivity differential "(RCD / Earth-Leakage)" switch, in compliance with local standards.

Make sure unauthorized people do not have access to the pump.

Disconnect the power supply to the electrical pump and unplug the machine before carrying out any maintenance, cleaning or handling operations.

If the power cord is damaged it must be replaced by qualified personnel to ensure against hazards.

Do not run the pump with the ports closed.

Be alert to hazardous situations caused by accidental power failure. Protect the pump from the weather.

Make sure the motor is properly ventilated.

Warning: the motor can reach a temperature of 95° Celsius in normal operation.

This appliance is not intended for use by persons (including children) with reduced physical, sensory or mental capabilities, or lack of experience and knowledge, unless they have been given supervision or instruction concerning use of the appliance by a person responsible for their safety. Children should be supervised to ensure that they do not play with the appliance.

If the supply cord is damaged, it must be replaced by the manufacturer, their service agent or similarly qualified persons in order to avoid a hazard.

9. WIRING DIAGRAM

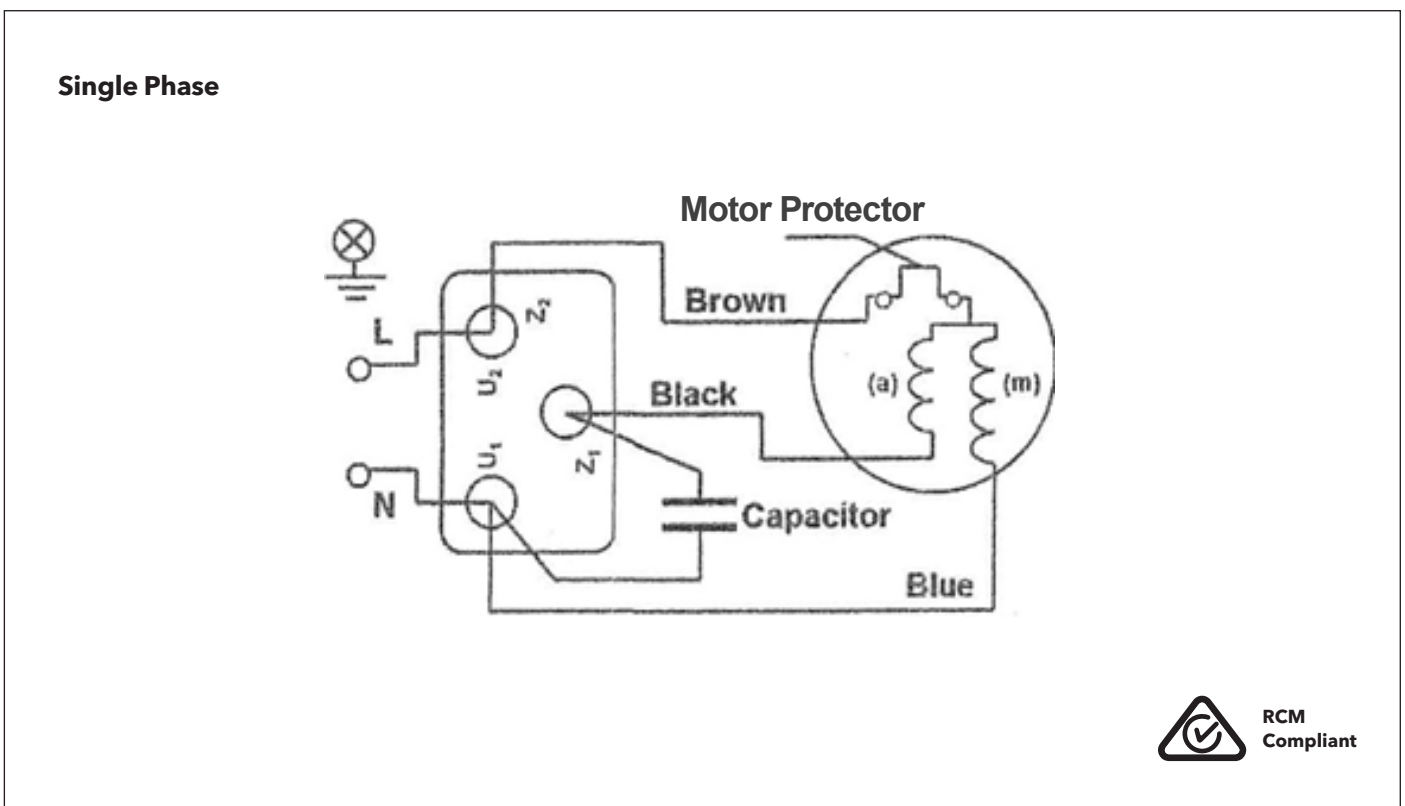

DIMENSIONAL SPECIFICATIONS

XBGR050 Dimensions (mm)

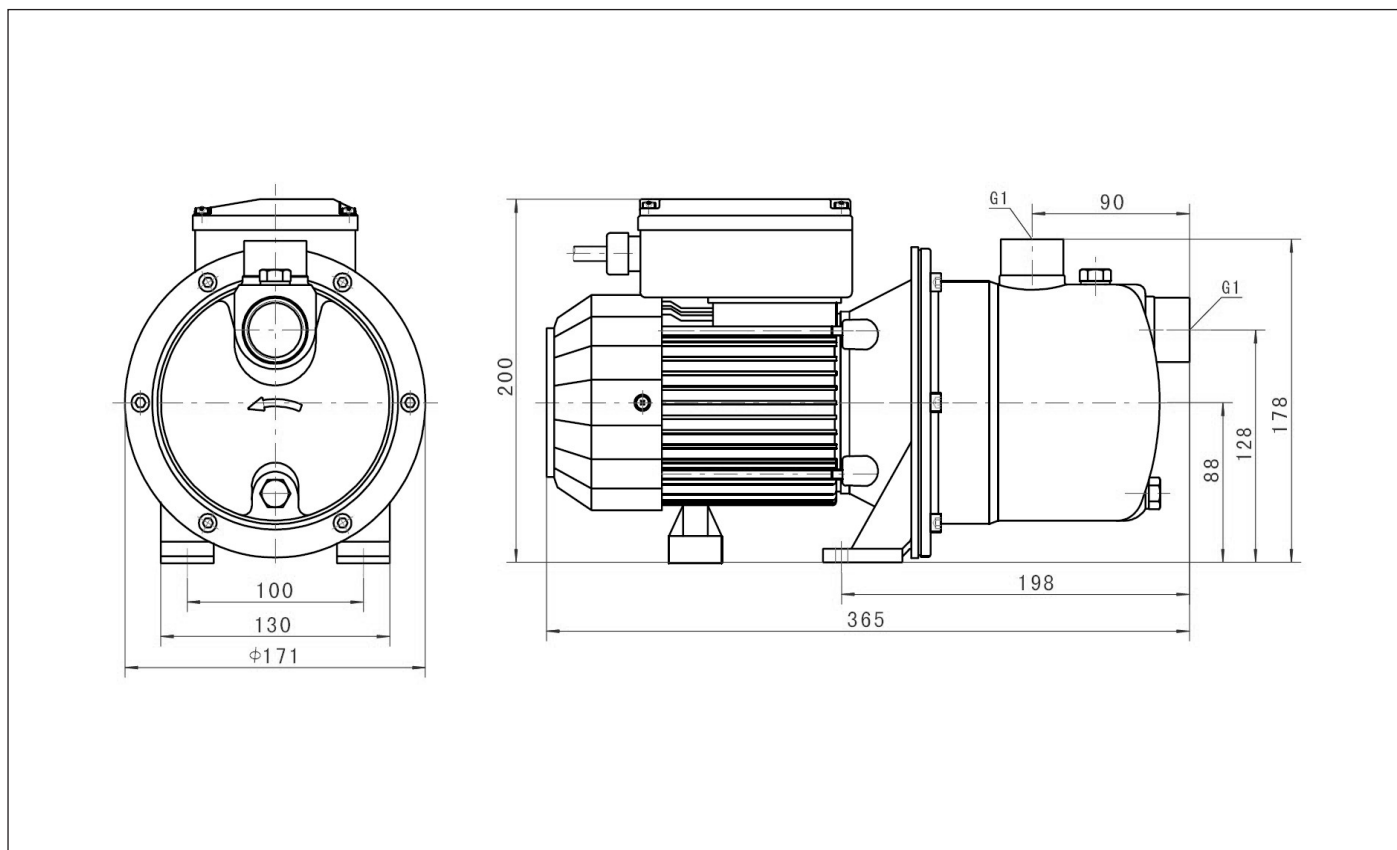

XBGR075, XBGR100 Dimensions (mm)

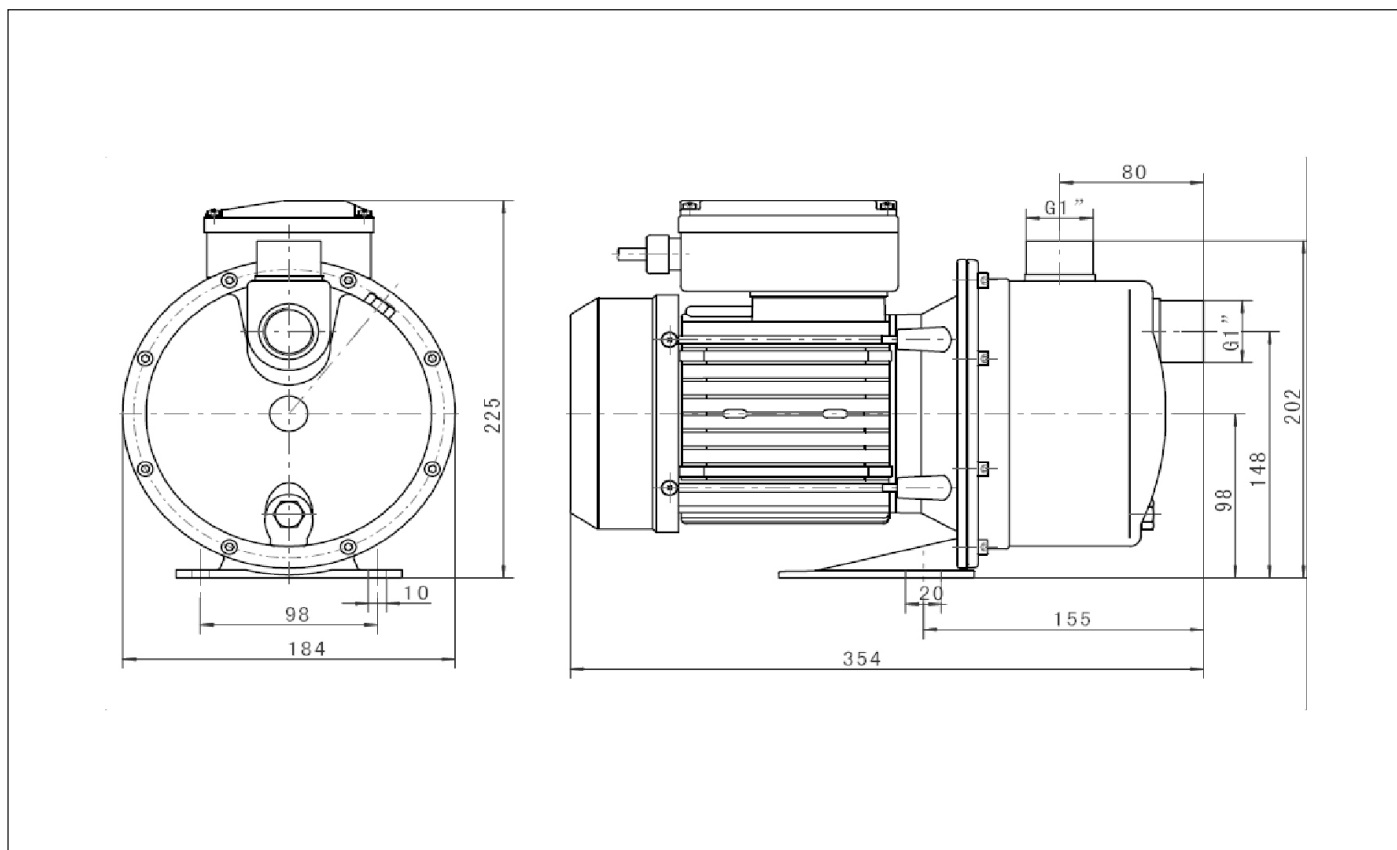

TROUBLESHOOTING GUIDE

PROBLEM	POSSIBLE CAUSE	SOLUTION
The pump does not deliver any flow	The suction or discharge pipes may be blocked.	Check the pipes.
	The suction pipes are leaking air.	Seal the pipes.
The pump has insufficient flow	The Impeller is damaged and / or corroded.	The impeller must be replaced.
	The mechanical seal is damaged and or corroded.	The mechanical seal must be replaced.
	The motor speed is lower than required.	Check for voltage fluctuation.
Loss of Head	Wrong Rotation.	Change motor wiring.
	The impeller is damaged and/or corroded.	The impeller must be replaced.
The motor is over-heating	The flow is beyond the end of the pump curve.	Make sure the correct pump was selected or adjust the outlet valve to reduce the flow and bring the pump within acceptable operating range.
	Mechanical wear is present. The motor fan is damaged. The motor is not properly ventilated.	Check and correct mechanical wear. The motor fan must be replaced. Provide good ventilation for the motor.
There is noise in the pump	The flow is outside acceptable operating range.	Make sure the correct pump was selected or adjust the outlet valve to reduce the flow and bring the pump within acceptable operating range.
	A nut may be loose.	Check and fasten, all loose nuts.
There is a big vibration In the motor	The vibration is caused by unbalanced/ insecure Installation.	Adjust the pump installation. Make sure to level up the base and correctly fasten the bracket bolts.
There is no suction. The motor runs but it gives no pressure	The pump was not primed properly.	Fill the pump body with water. Prime the pump according to instructions.
The motor does not start	The fuse has blown. The thermal protector may have activated.	Visual Check for fault. Ask Qualified electrician. Replace the fuse. Allow the motor to cool down to reset the thermal protector.

GOULDS WATER TECHNOLOGY LIMITED WARRANTY

This warranty applies to all pumps and related accessories manufactured and/or supplied by Goulds Water Technology, provided the installation is in accordance with the Instruction Manual issued by the Manufacturer.

Any part or parts found to be defective within the warranty period shall be replaced at no charge to the buyer or any subsequent owner during the warranty period. The warranty period shall exist for a period of twelve (12) months from the date of installation or eighteen (18) months from the date of manufacture, whichever is shorter.

A consumer who believes that a warranty claim exists must contact the authorised Goulds Water Technology dealer from whom the equipment was originally purchased and furnish complete details regarding the claim for warranty.

This warranty excludes:

- a. Labor, transportation and related costs incurred by the consumer to make the alleged defective equipment available to the dealer for inspection.
- b. Re-installation costs of repaired equipment.
- c. Re-installation costs of replacement equipment.
- d. Consequential damages of any kind.
- e. Reimbursement for loss caused by interruption of service.

There are no warranties, expressed or implied, except such warranties as are definitely set forth herein. The company shall not be liable for damage or wear to pump caused by abnormal conditions, failure to properly prime or to operate pump without flow or caused by corrosives, abrasives, or foreign objects. No obligations other than those herein set forth shall be binding upon the company.



Australia
Phone: 13 19 14
Email: solve@xylem.com
www.xylem.com/au

New Zealand
Phone: 0800 33 19 14
Email: solve.nz@xylem.com
www.xylem.com/nz



**RCM
Compliant**



**AS4020 Certified
Suitable for
Drinking Water**

Lowara, Bell & Gossett and AC Fire Pump are trademarks of Xylem Inc.
Goulds is a registered trademark of Goulds Pumps, Inc and is used under this license.