

**FMC** Technologies



500



# Pump Engineering Data Book



A prolific inventor, John Bean interrupted his California retirement in 1884 to develop a continuous spray pump to combat orchard scale. The rest is FMC history.

## FMC Technologies Pump History

FMC Technologies is a leading manufacturer of reciprocating pumps on a global basis. Backed by a worldwide support network, FMC Technologies pumps are found performing in demanding applications throughout the world. Ever since the company began with the invention of a high-pressure pump by John Bean in 1884, it has had one overriding objective: *Providing outstanding value to customers*. FMC Technologies accomplishes this objective by introducing innovative technology, manufacturing and delivering high quality pumps on a timely basis, and having a well-trained organization around the world to support FMC Technologies pumps. Today, FMC Technologies produces a complete range of Bean® Piston Pumps and FMC Technologies Plunger Pumps for the oil and gas, reverse osmosis, drilling, sprayer, and general industries.

## FMC Technologies Leadership In Pump Technology

1884	First constant pressure pump
1918	First relief valve used to regulate pressure
1941	Used in fog fire fighting equipment
1951	Ceramic cylinders introduced
1957	Used in the first nuclear submarine
1961	Spring loaded disc valves introduced
1984	Computer aided design and manufacturing systems installed
1990	Introduction of low pulse and API 674 technology
1995	ISO 9001 manufacturing certification



# Contents

4	<b>Piston Pump Overview</b>	42	M14 Plunger Pump Data
6	Ao4 Piston Pump Data	46	M16 Plunger Pump Data
8	Io4 Piston Pump Data	50	M18 Plunger Pump Data
10	Eo4 Piston Pump Data	54	M28 Plunger Pump Data
12	Lo6 Piston Pump Data	58	Q16 Plunger Pump Data
14	Lo6HV and HV Compact Piston Pump Data	62	Q18 Plunger Pump Data
16	Log Piston Pump Data	66	Q28 Plunger Pump Data
18	LogHV Piston Pump Data	70	Q32 Plunger Pump Data
20	W11 Piston Pump Data	74	<b>Standard Pump Material Information</b>
22	L11 Piston Pump Data	76	<b>Pump Options/Adders Information</b>
24	L16 Piston Pump Data	80	<b>Pump System Ideal Drawing</b>
26	<b>Plunger Pump Overview</b>	80	<b>Pump System Information</b>
28	Do4 Plunger Pump Data	81	<b>Reference Calculations</b>
30	Mo6 Plunger Pump Data	82	<b>Common Conversions</b>
34	Mo8 Plunger Pump Data	82	<b>Warning and Safety Instructions</b>
38	M12 Plunger Pump Data	83	<b>FMC Pump Manufacturing Information</b>

## Pump Quick Reference Chart

	Model	Max PSI	Max GPM	Max BHP	Cast Iron	Ductile Iron	NiAlBz NiAl	Carbon Steel	Alloy Steel	Stainless Steel	Exotic
BEAN Piston	Ao4/Io4	850	9.0	3.2	x		x				
	Eo4	850	18.5	7.0	x		x				
	Lo6	1,000	38.8	17.6		x	x				
	Lo6-HV	1,200	42.6	20.7		x	x			x	
	Log	1,200	28.7	13.8	x						
	Log-HV	1,500	52.3	27.1		x	x			x	
	W11	1,000	53.0	36	x						
	L11	2,500	75.1	52		x	x	x		x	
	L12	2,500	92.6	61		x	x	x		x	
L16	2,500	113.5	87		x	x	x		x		
FMC Plunger	Do4	2,150	4.1	3.2				x	x	x	
	Mo6	10,000	32.3	21		x	x	x		x	x
	Mo8	10,000	76.5	45		x	x	x		x	x
	M12	10,000	138	77		x	x	x		x	x
	M14	10,000	213	104		x	x	x	x	x	x
	M16	10,000	351	142		x	x	x	x	x	x
	M18	10,000	372	190		x	x	x	x	x	x
	Q16	10,000	585	240		x	x	x	x	x	x
	Q18	10,000	620	325		x	x	x	x	x	x
	M28	10,000	837	440			x	x	x	x	x
	Q28	10,000	1,395	800			x	x	x	x	x
	Q32	10,000	1,594	1,000			x	x	x	x	x

# Piston pumps

FMC Technologies Piston Pumps are engineered and designed to meet the market needs and requirements. By working together with it's customers, FMC Technologies customizes the designs and innovative component technology to optimize pump efficiency in the most extreme working conditions. The lower life cycle cost can be contributed to designing longer lasting parts with innovative wear characteristics into the pumping solution. Increased priming characteristics can be achieved with low clearance volume fluid chambers. The piston pumps are designed to enable service in the field, decrease any unnecessary downtime and increase production profit output.

FMC Technologies Piston Pumps continue to create value that is unsurpassed in the industry. The versatility of a broad range of piston products combined with innovative design, component technology with lower life cycle cost and serviceability allows FMC Technologies to focus on Tomorrow's Engineered Solutions Today.

Shaft configurations provide maximum flexibility. Straight-keyed shaft or splined shafts are available for hydraulic motors and external gear reducers.

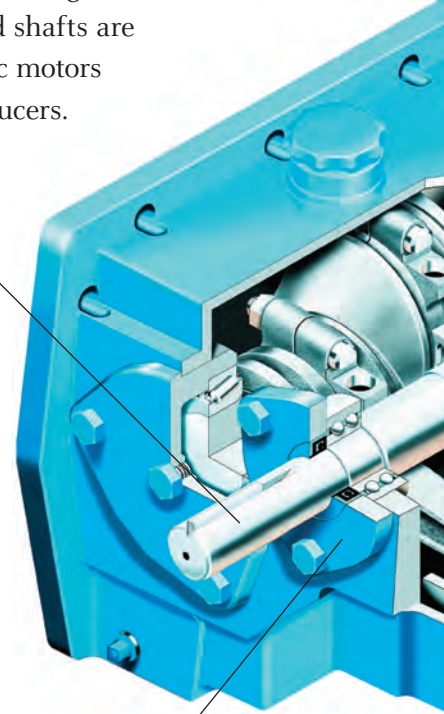

Compact Power Frames (many with built-in gear reduction) simplify installation in mobile or space-constrained applications.

The Piston Pump Product line is available in up to 700 horsepower and designed for continuous duty industrial applications. The piston pump product is available in triplex, quintuplex or quadruplex configurations and operate up to 2,500 psi with flows up to 944 gpm. Pumps can incorporate ductile iron, aluminum bronze and other materials as required by the application.

Solid Ceramic Piston Liners provide the ultimate in wear and corrosion resistance.

Durable Fluid End designs enhance priming characteristics and component service life.

Removable Cylinder Covers allow for fast, easy maintenance of the packing without removal of the fluid end or piping.

Standard Disc Valves provide quiet, efficient performance in most applications. Abrasion-resistant and ball style valves are available to suit high-performance applications.

Piston Cups incorporate a unique geometry with composite rubber and fabric construction for reliable, leak-tight performance.

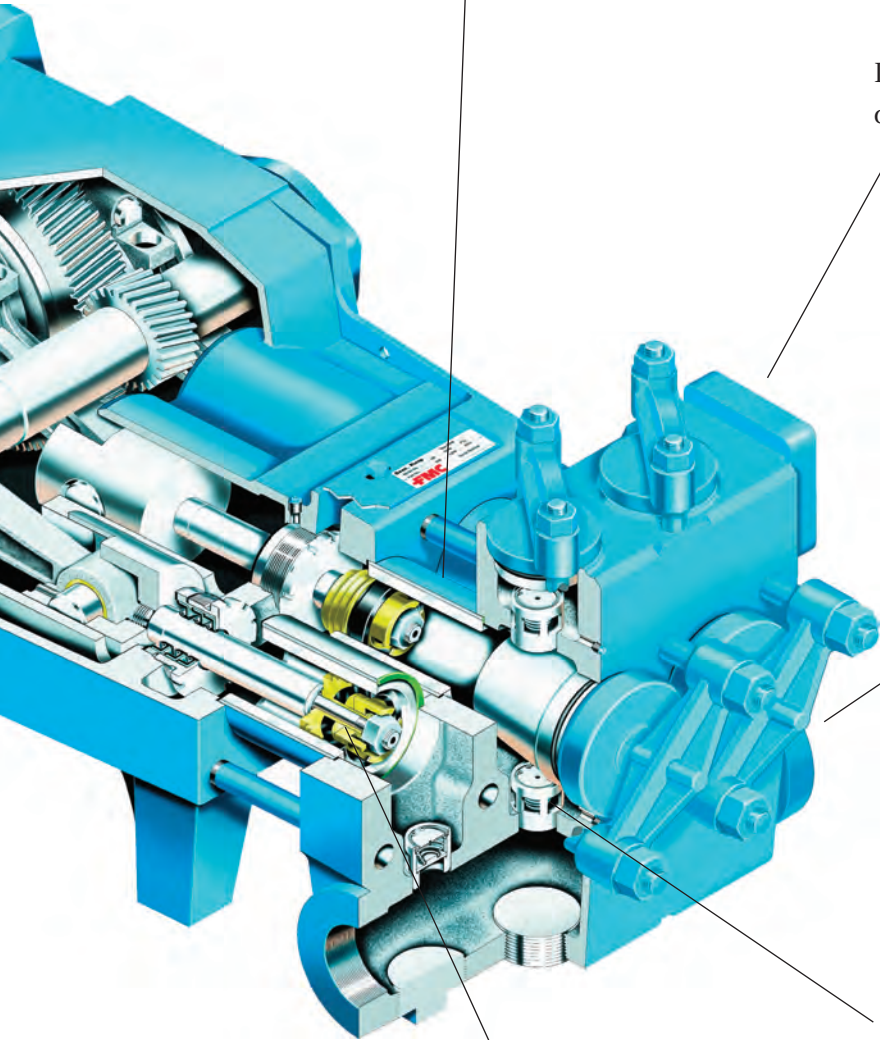

Overall, FMC Technologies broad product offering, serviceability, innovative designs and component technology increases productivity by decreasing downtime. FMC Technologies Piston Pumps continue to lower overall cost of ownership by providing Tomorrow's Market Solutions Today.

## Ao4 Piston Pump Data

2.6 BHP Continuous Duty (3.2 BHP Intermittent Duty)

### Ao4

Standard Cast ISO Drawing

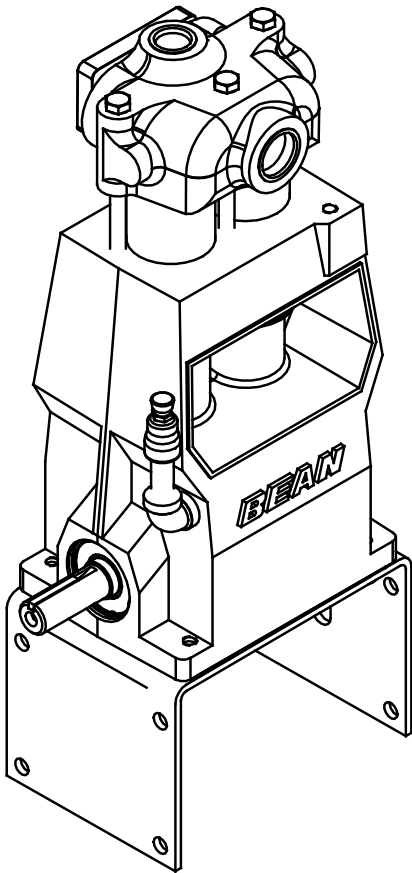

## Specifications

Pump Model	Ao4
Configuration	Ao4 Vertical Duplex Piston
Number of Pistons	2
Stroke Length	1.0 Inches
Frame Load Rating	1,140 lbs
Pump Weight (Average)	43 lbs
Direction of Rotation	Either
Internal Gear Ratio	NA
Intermittent Duty Speed Rating	500 RPM
Continuous Duty Speed Rating	400 RPM
Ball Valve Max Speed Rating	NA
Minimum Speed	300 RPM
Mechanical Efficiency	90%
Lubrication System (Standard)	Splash, Gravity Return
Lube Oil Capacity	1 Quart
Lube Oil Type	SAE 30
Maximum Fluid Temperature	140 °F (250 °F Capability)
Minimum Fluid Temperature	0 °F (-20 °F Capability)
Standard Suction Size	1.00 Inch NPT
Standard Discharge Size	0.50 Inch NPT 0.75 Inch NPT
Fluid End Material	Cast Iron, Aluminum Bronze
Valve Types	Disc Valves
Hydraulic Motor Mount	SAE A - 2 Bolt with 7/8"-13T

## Performance Table

Pump Model	Piston Diameter (in)	Displacement (GAL/REV)	Maximum Pressure (PSI)	Pump Capacity (GPM) @ Input Speed (RPM)				
				300 RPM	350 RPM	375RPM	400RPM	500RPM
Ao410	1.250	0.0106	850	3.19	3.72	3.98	4.25	5.31
Ao411	1.375	0.0129	750	3.86	4.50	4.82	5.14	6.43
Ao413	1.625	0.0180	550	5.39	6.28	6.73	7.18	8.98

\* Horsepower based on 85 or 90% mechanical efficiency. Actual application horsepower requirements can be calculated using the equation:  
 $BHP = (GPM * PSI) / (1714 * 0.85 \text{ or } 0.90)$

\* Pump capacities shown are based on 100% volumetric efficiency.

\* Dimensions shown are for general sizing purposes and should not be used for construction. Contact FMC for actual dimensions of pump ordered.

\* FMC reserves the right to modify this information without prior notice.

## Ao4 Cast Pump Engineering Dimensional Outline

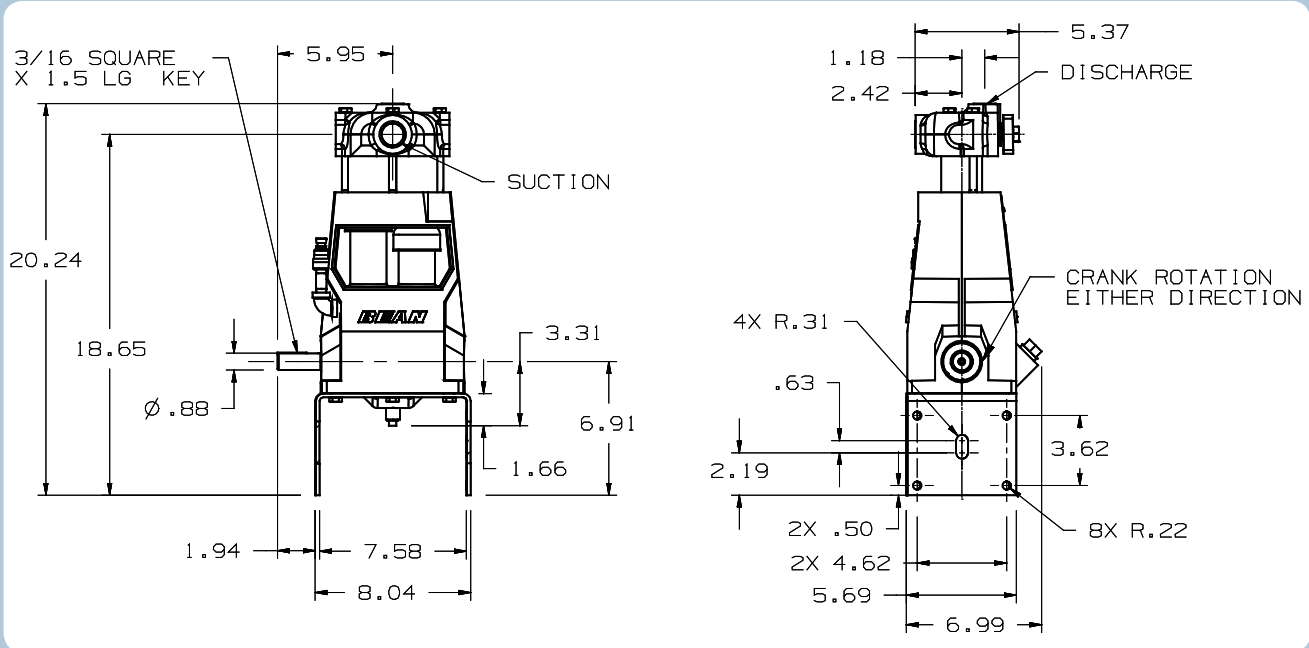

## Ao4 NPSHr value for Standard Disc Valves

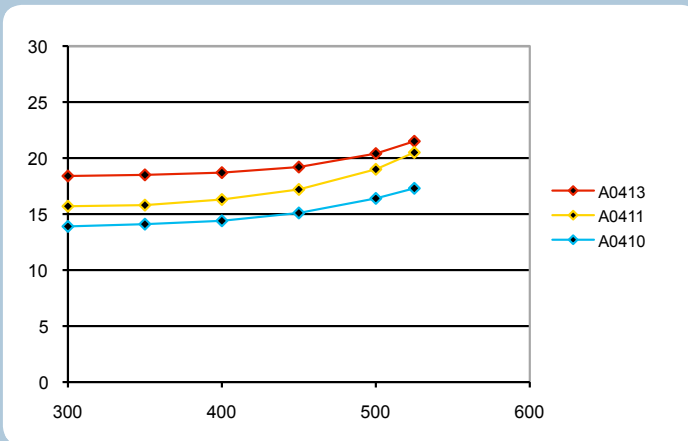

- FMC recommends NPSHa (available) exceeds NPSHr (required) by 5 feet of water.
- Take special consideration when calculating NPSHa. Recalculate NPSHa after pump model has been selected for more accurate values.
- NPSHr values are in feet of water. If you are pumping a different liquid than water, convert the required NPSH from water to the liquid being pumped by dividing the published NPSHr value by the specific gravity of the liquid being pumped.
- FMC published NPSHr values are based on test data collected on specific pumps at the factory and are estimated values. Actual NPSHr values for an ordered pump can only be determined by a factor test. For NPSH critical applications, contact the factory for additional information and request an NPSHr test performed on your pump before shipment.
- Pump drawing dimensions in inches.

## 1o4 Piston Pump Data

2.6 BHP Continuous Duty (3.2 BHP Intermittent Duty)

### 1o4

Standard Cast ISO Drawing

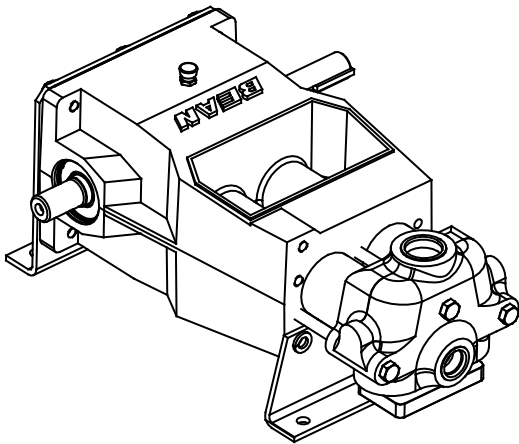

## Specifications

Pump Model	1o4
Configuration	1o4 Horizontal Duplex Piston
Number of Pistons	2
Stroke Length	1.0 Inches
Frame Load Rating	1,140 lbs
Pump Weight (Average)	43 lbs
Direction of Rotation	Either
Internal Gear Ratio	NA
Intermittent Duty Speed Rating	500 RPM
Continuous Duty Speed Rating	400 RPM
Ball Valve Max Speed Rating	NA
Minimum Speed	100 RPM
Mechanical Efficiency	90%
Lubrication System (Standard)	Splash, Gravity Return
Lube Oil Capacity	1 Quart
Lube Oil Type	SAE 30
Maximum Fluid Temperature	140 °F (250 °F Capability)
Minimum Fluid Temperature	0 °F (-20 °F Capability)
Standard Suction Size	1.00 Inch NPT
Standard Discharge Size	0.50 Inch NPT 0.75 Inch NPT
Fluid End Material	Cast Iron, Aluminum Bronze
Valve Types	Disc Valves
Hydraulic Motor Mount	SAE A - 2 Bolt with 7/8"-13T

## Performance Table

Pump Model	Piston Diameter (in)	Displacement (GAL/REV)	Maximum Pressure (PSI)	Pump Capacity (GPM) @ Input Speed (RPM)				
				300 RPM	350 RPM	375RPM	400RPM	500RPM
1o410	1.250	0.0106	850	3.19	3.72	3.98	4.25	5.31
1o411	1.375	0.0129	750	3.86	4.50	4.82	5.14	6.43
1o413	1.625	0.0180	550	5.39	6.28	6.73	7.18	8.98

\* Horsepower based on 85 or 90% mechanical efficiency. Actual application horsepower requirements can be calculated using the equation:  
 $BHP = (GPM * PSI) / (1714 * 0.85 \text{ or } 0.90)$

\* Pump capacities shown are based on 100% volumetric efficiency.

\* Dimensions shown are for general sizing purposes and should not be used for construction. Contact FMC for actual dimensions of pump ordered.

\* FMC reserves the right to modify this information without prior notice.

## 104 Cast Pump Engineering Dimensional Outline

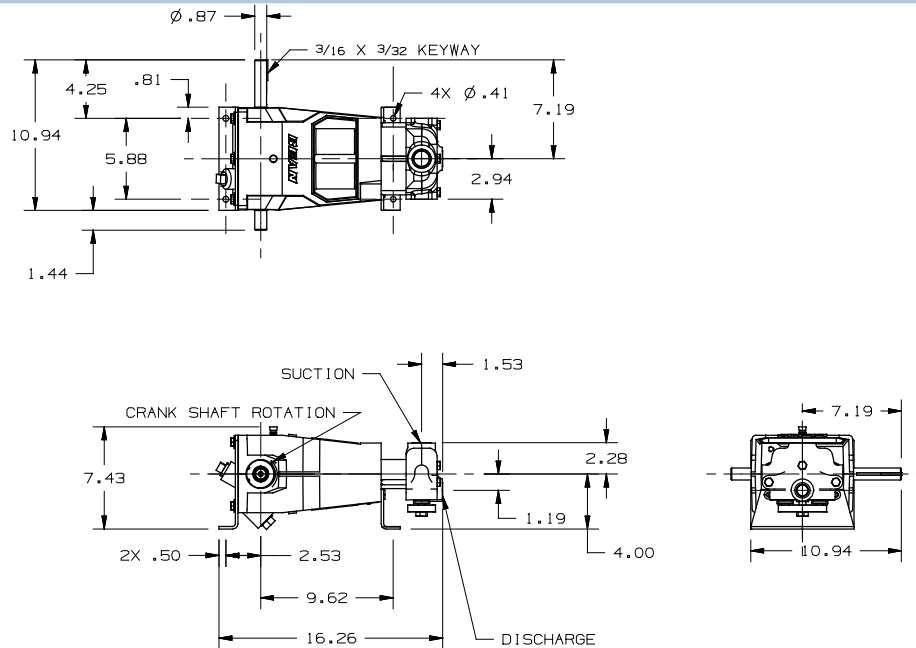

## 104 NPSHr value for Standard Disc Valves

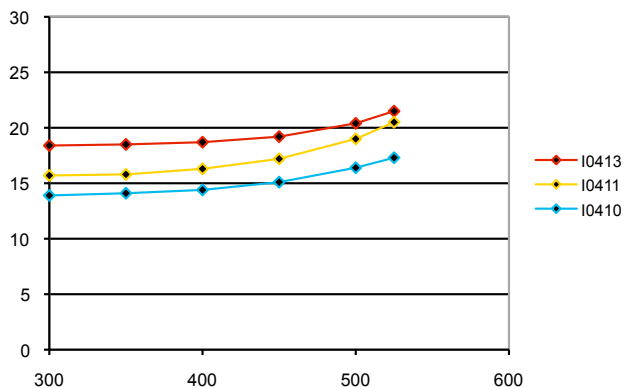

- FMC recommends NPSHa (available) exceeds NPSHr (required) by 5 feet of water.
- Take special consideration when calculating NPSHa. Recalculate NPSHa after pump model has been selected for more accurate values.
- NPSHr values are in feet of water. If you are pumping a different liquid than water, convert the required NPSH from water to the liquid being pumped by dividing the published NPSHr value by the specific gravity of the liquid being pumped.
- FMC published NPSHr values are based on test data collected on specific pumps at the factory and are estimated values. Actual NPSHr values for an ordered pump can only be determined by a factor test. For NPSH critical applications, contact the factory for additional information and request an NPSHr test performed on your pump before shipment.
- Pump drawing dimensions in inches.

For additional information visit [FMCPumps.com](http://FMCPumps.com)

## Eo4 Piston Pump Data

6.1 BHP Continuous Duty (7.0 BHP Intermittent Duty)

### Eo4

Standard Cast ISO Drawing

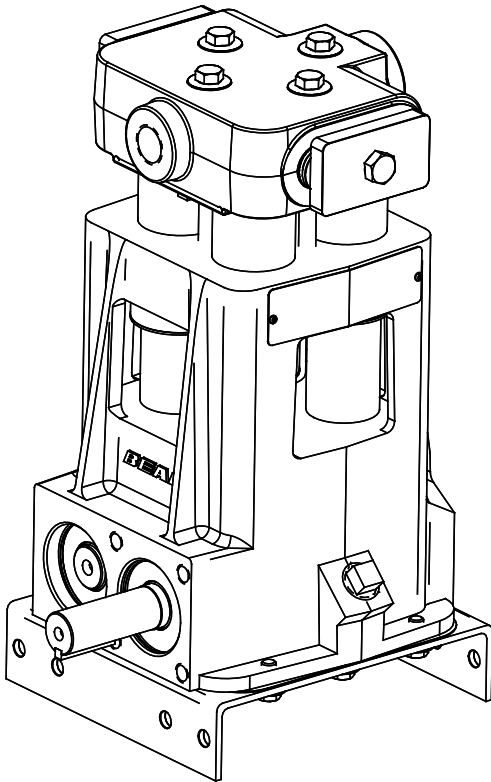

## Specifications

Pump Model	Eo4
Configuration	Verticle Quadruplex Piston
Number of Pistons	4
Stroke Length	1.0 Inches
Frame Load Rating	1,240 lbs
Pump Weight (Average)	80 lbs
Direction of Rotation	Either
Internal Gear Ratio	1:1
Intermittent Duty Speed Rating	515 RPM
Continuous Duty Speed Rating	450 RPM
Ball Valve Max Speed Rating	NA
Minimum Speed	390 RPM
Mechanical Efficiency	85%
Lubrication System (Standard)	Splash, Gravity Return
Lube Oil Capacity	1 Quart
Lube Oil Type	SAE 30
Maximum Fluid Temperature	140 °F (250 °F Capability)
Minimum Fluid Temperature	0 °F (-20 °F Capability)
Standard Suction Size	1.25 Inch NPT
Standard Discharge Size	0.75 Inch NPT
Fluid End Material	Cast Iron, Aluminum Bronze
Valve Types	Disc Valves
Hydraulic Motor Mount	SAE A - 2 Bolt with 1"-6B

## Performance Table

Pump Model	Piston Diameter (in)	Displacement (GAL/REV)	Maximum Pressure (PSI)	Pump Capacity (GPM) @ Input Speed (RPM)				
				390 RPM	400 RPM	425RPM	450RPM	515RPM
Eo410	1.250	0.0212	850	8.29	8.50	9.03	9.56	10.94
Eo411	1.375	0.0257	750	10.03	10.28	10.93	11.57	13.24
Eo413	1.625	0.0359	550	14.01	14.36	15.26	16.16	18.49

\* Horsepower based on 85 or 90% mechanical efficiency. Actual application horsepower requirements can be calculated using the equation:  $BHP = (GPM * PSI) / (1714 * 0.85 \text{ or } 0.90)$

\* Pump capacities shown are based on 100% volumetric efficiency.

\* Dimensions shown are for general sizing purposes and should not be used for construction. Contact FMC for actual dimensions of pump ordered.

\* FMC reserves the right to modify this information without prior notice.

## Eo4 Cast Pump Engineering Dimensional Outline

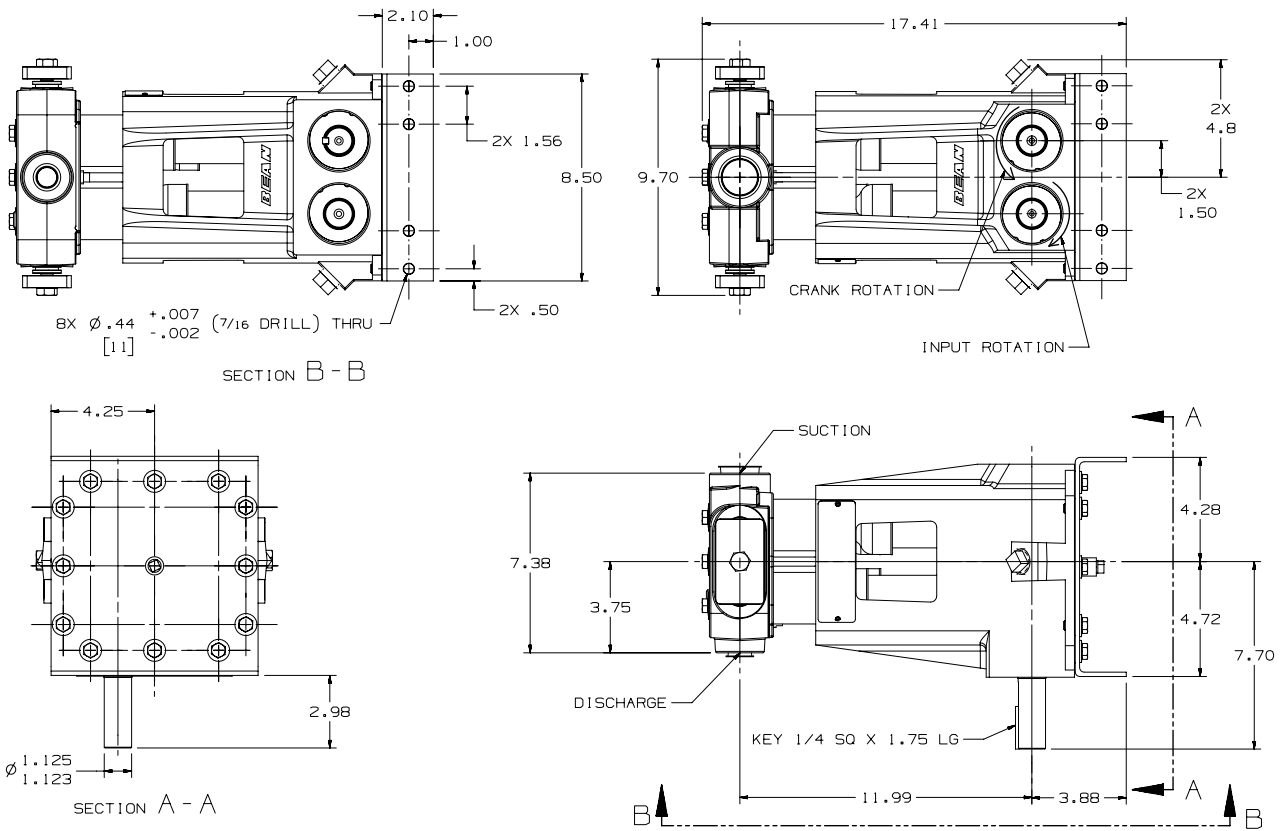

## Eo4 NPSHr value for Standard Disc Valves

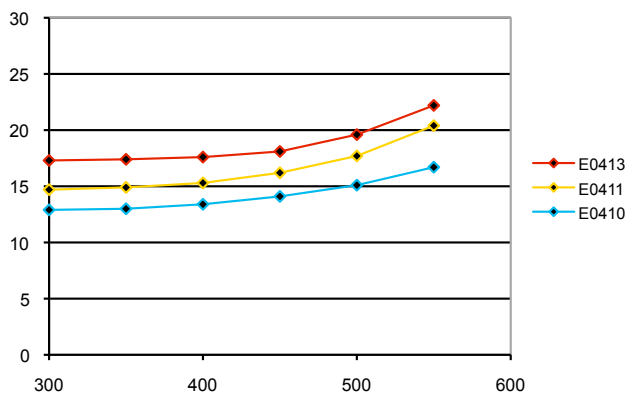

- FMC recommends NPSHa (available) exceeds NPSHr (required) by 5 feet of water.
- Take special consideration when calculating NPSHa. Recalculate NPSHa after pump model has been selected for more accurate values.
- NPSHr values are in feet of water. If you are pumping a different liquid than water, convert the required NPSH from water to the liquid being pumped by dividing the published NPSHr value by the specific gravity of the liquid being pumped.
- FMC published NPSHr values are based on test data collected on specific pumps at the factory and are estimated values. Actual NPSHr values for an ordered pump can only be determined by a factor test. For NPSH critical applications, contact the factory for additional information and request an NPSHr test performed on your pump before shipment.
- Pump drawing dimensions in inches.

## Lo6 Piston Pump Data

12.3 BHP Continuous Duty (17.6 BHP Intermittent Duty)

### Lo6

Standard Cast ISO Drawing

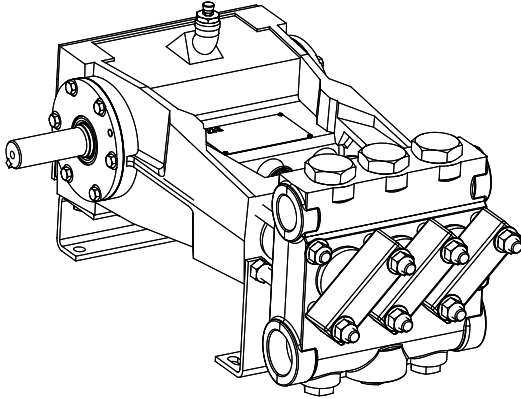

## Specifications

Pump Model	Lo6
Configuration	Horizontal Triplex Piston
Number of Pistons	3
Stroke Length	1.5 Inches
Frame Load Rating	2,800 lbs
Pump Weight (Average)	175 lbs
Direction of Rotation	Top of shaft toward head
Internal Gear Ratio	NA
Intermittent Duty Speed Rating	500 RPM
Continuous Duty Speed Rating	350 RPM
Ball Valve Max Speed Rating	200 RPM
Minimum Speed	100 RPM
Mechanical Efficiency	90%
Lubrication System (Standard)	Splash, Gravity Return
Lube Oil Capacity	2 Quarts
Lube Oil Type	SAE 30
Maximum Fluid Temperature	140 °F (250 °F Capability)
Minimum Fluid Temperature	0 °F (-20 °F Capability)
Standard Suction Size	1.50 Inch NPT
Standard Discharge Size	1.25 Inch NPT
Fluid End Material	Ductile Iron Nickle Aluminum Bronze
Valve Types	Disc Valves
Hydraulic Motor Mount	SAE A - 2 Bolt with 1.25"-14T SAE B - 2 Bolt with 1.25"-14T SAE B - 4 Bolt with 1.25"-14T

## Performance Table

Pump Model	Piston Diameter (in)	Displacement (GAL/REV)	Maximum Pressure (PSI)	Pump Capacity (GPM) @ Input Speed (RPM)				
				100 RPM	200 RPM	300 RPM	350 RPM	500 RPM
Lo614	1.750	0.0469	1,000	4.7	9.4	14.1	16.4	23.4
Lo618	2.250	0.0775	700	7.7	15.5	23.2	27.1	38.7

\* Horsepower based on 85 or 90% mechanical efficiency. Actual application horsepower requirements can be calculated using the equation:  $BHP = (GPM * PSI) / (1714 * 0.85 \text{ or } 0.90)$

\* Pump capacities shown are based on 100% volumetric efficiency.

\* Dimensions shown are for general sizing purposes and should not be used for construction. Contact FMC for actual dimensions of pump ordered.

\* FMC reserves the right to modify this information without prior notice.

## Lo6

### Cast Pump Engineering Dimensional Outline

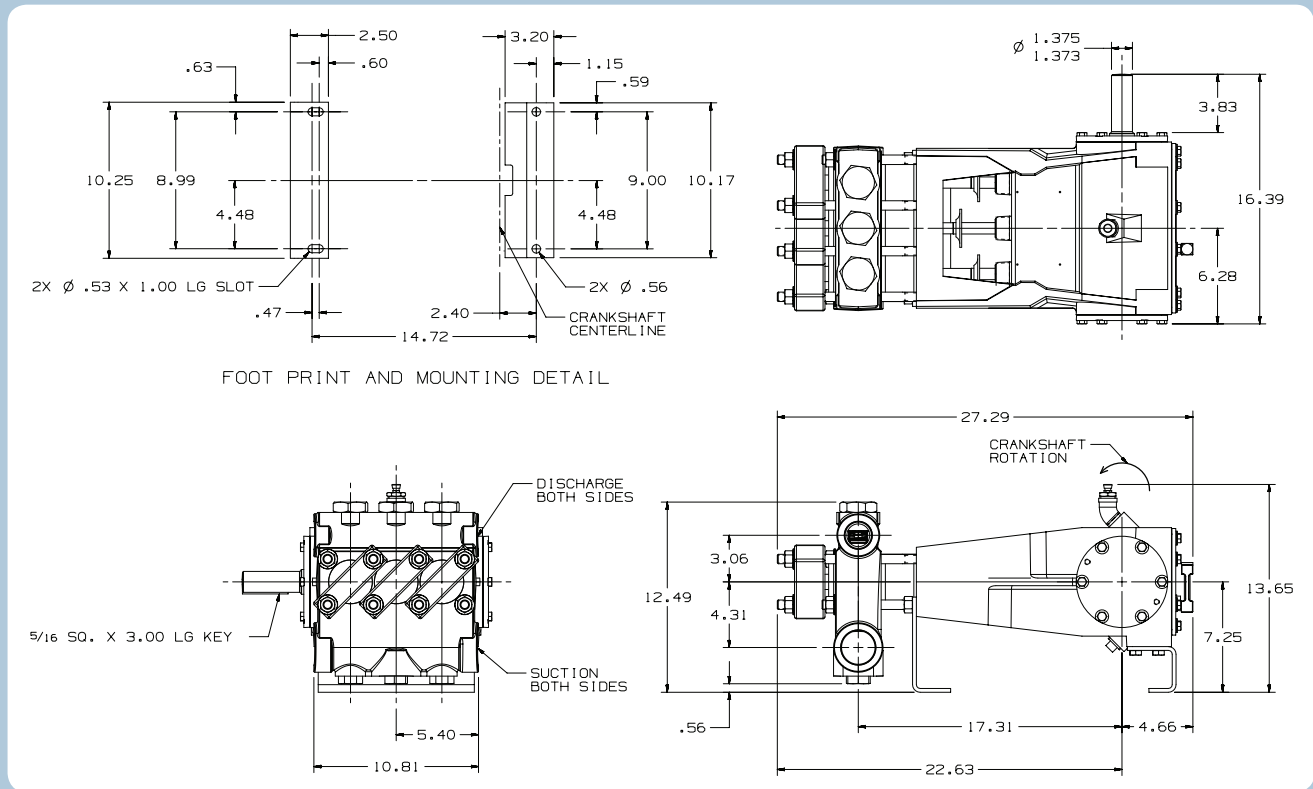

### Lo6 NPSHr value for Standard Disc Valves

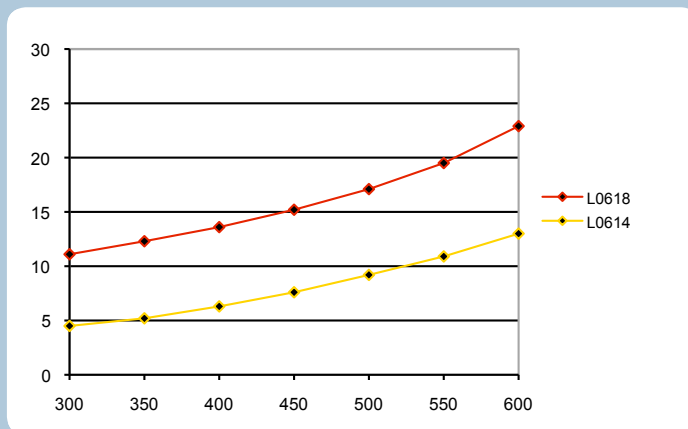

- FMC recommends NPSHa (available) exceeds NPSHr (required) by 5 feet of water.
- Take special consideration when calculating NPSHa. Recalculate NPSHa after pump model has been selected for more accurate values.
- NPSHr values are in feet of water. If you are pumping a different liquid than water, convert the required NPSH from water to the liquid being pumped by dividing the published NPSHr value by the specific gravity of the liquid being pumped.
- FMC published NPSHr values are based on test data collected on specific pumps at the factory and are estimated values. Actual NPSHr values for an ordered pump can only be determined by a factor test. For NPSH critical applications, contact the factory for additional information and request an NPSHr test performed on your pump before shipment.
- Pump drawing dimensions in inches.

## Lo6HV and HV Compact Piston Pump Data (High Volume)

15.1 BHP Continuous Duty (20.7 BHP Intermittent Duty)

### Lo6 HV

Standard Cast ISO Drawing

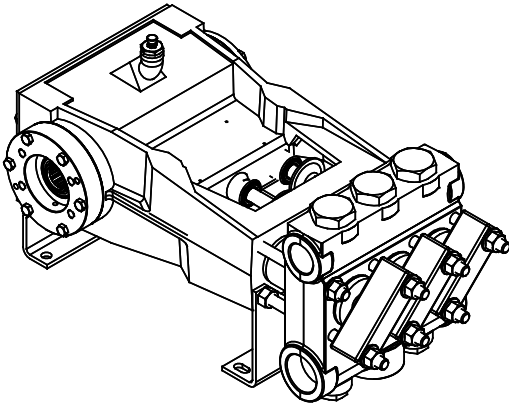

### Lo6 HV Compact

Standard Cast ISO Drawing

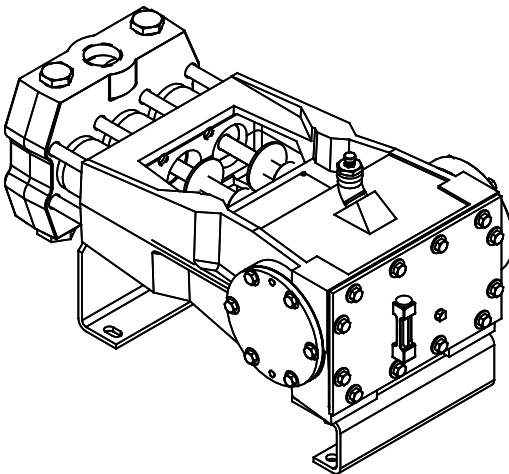

## Specifications

Pump Model	Lo6HV and HV Compact
Configuration	Horizontal Triplex Piston
Number of Pistons	3
Stroke Length	1.5 Inch
Frame Load Rating	2,800 lbs
Pump Weight (Average)	225 lbs
Direction of Rotation	Top of shaft toward head
Internal Gear Ratio	NA
Intermittent Duty Speed Rating	550 RPM
Continuous Duty Speed Rating	400 RPM
Ball Valve Max Speed Rating	200 RPM
Minimum Speed	100 RPM
Mechanical Efficiency	90%
Lubrication System (Standard)	Splash, Gravity Return
Lube Oil Capacity	2 Quarts
Lube Oil Type	SAE 30
Maximum Fluid Temperature	140 °F (250 °F Capability)
Minimum Fluid Temperature	0 °F (-20 °F Capability)
Standard Suction Size (HV)	2.00 Inch NPT
Standard Discharge Size (HV)	1.50 Inch NPT
Standard Suction Size (Compact)	1.50 Inch NPT
Standard Discharge Size (Compact)	1.50 Inch NPT
Fluid End Material	Ductile Iron Nickle Aluminum Bronze
Valve Types (HV)	Disc Valves, Abrasion Resistant (AR) Valves
Valve Type (HVCompact)	Abrasion Resistant (AR) Valves
Hydraulic Motor Mount	SAE A - 2 Bolt with 1.25"-14T SAE B - 2 Bolt with 1.25"-14T SAE B - 4 Bolt with 1.25"-14T

## Performance Table

Pump Model	Piston Diameter (in)	Displacement (GAL/REV)	Maximum Pressure (PSI)	Pump Capacity (GPM) @ Input Speed (RPM)				
				100 RPM	200 RPM	300 RPM	400 RPM	550 RPM
Lo614-HV	1.750	0.0469	1,000	4.7	9.4	14.1	18.7	25.8
Lo618-HV	2.250	0.0775	700	7.7	15.5	23.2	31.0	42.6

\* Horsepower based on 85 or 90% mechanical efficiency. Actual application horsepower requirements can be calculated using the equation:  $BHP = (GPM * PSI) / (1714 * 0.85 \text{ or } 0.90)$

\* Pump capacities shown are based on 100% volumetric efficiency.

\* Dimensions shown are for general sizing purposes and should not be used for construction. Contact FMC for actual dimensions of pump ordered.

\* FMC reserves the right to modify this information without prior notice.

## Lo6 HV

### Cast Pump Engineering Dimensional Outline

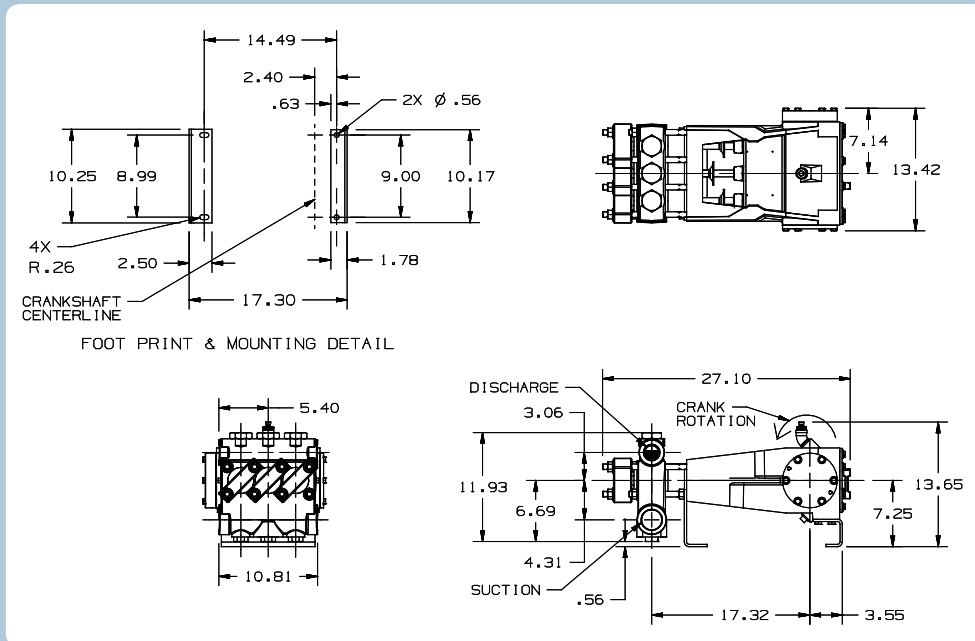

## Lo6 HV Compact

### Cast Pump Engineering Dimensional Outline

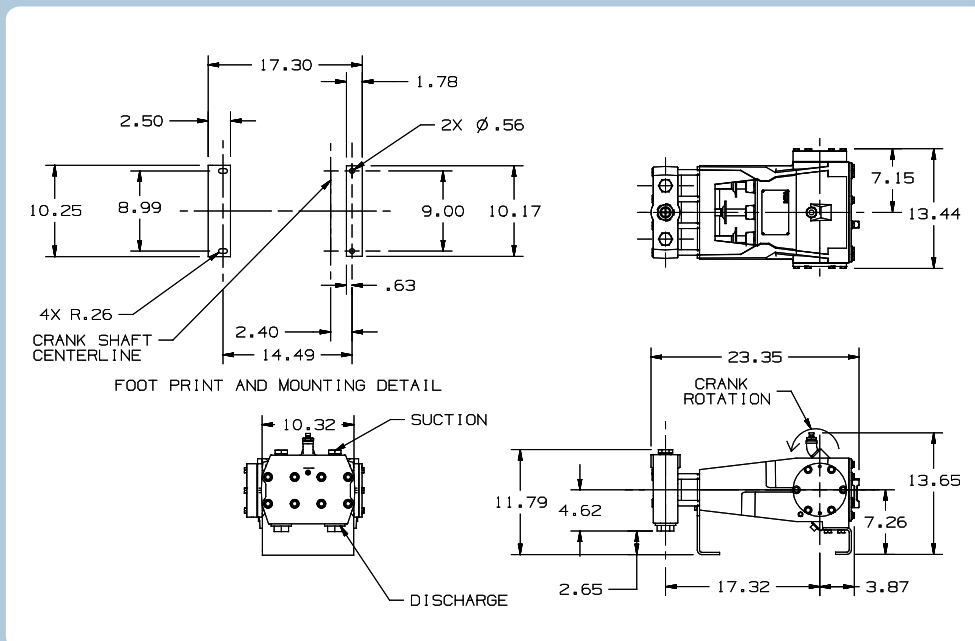

- FMC recommends NPSHa (available) exceeds NPSHr (required) by 5 feet of water.
- Take special consideration when calculating NPSHa. Recalculate NPSHa after pump model has been selected for more accurate values.
- NPSHr values are in feet of water. If you are pumping a different liquid than water, convert the required NPSH from water to the liquid being pumped by dividing the published NPSHr value by the specific gravity of the liquid being pumped.
- FMC published NPSHr values are based on test data collected on specific pumps at the factory and are estimated values. Actual NPSHr values for an ordered pump can only be determined by a factor test. For NPSH critical applications, contact the factory for additional information and request an NPSHr test performed on your pump before shipment.
- Pump drawing dimensions in inches.

# FMC Technologies

## Log Piston Pump Data

11.6 BHP Continuous Duty (13.8 BHP Intermittent Duty)

### Log

Standard Cast ISO Drawing

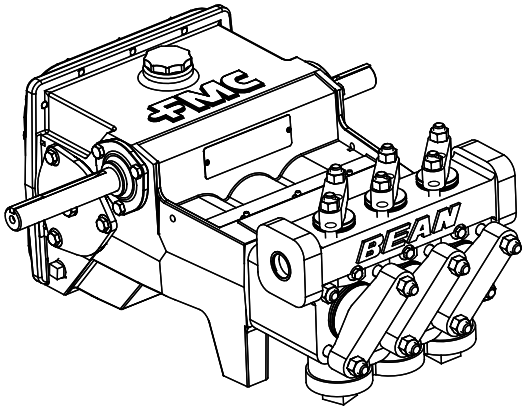

### Specifications

Pump Model	Log
Configuration	Horizontal Triplex Piston
Number of Pistons	3
Stroke Length	2.25 Inches
Frame Load Rating	2,800 lbs
Pump Weight (Average)	200 lbs
Direction of Rotation	Top of shaft away from head
Internal Gear Ratio	3.6:1
Intermittent Duty Speed Rating	890 RPM
Continuous Duty Speed Rating	750 RPM
Ball Valve Max Speed Rating	625 RPM
Minimum Speed	360 RPM
Mechanical Efficiency	85%
Lubrication System (Standard)	Splash, Gravity Return
Lube Oil Capacity	2.25 Quarts
Lube Oil Type	SAE 30
Maximum Fluid Temperature	140 °F (250 °F Capability)
Minimum Fluid Temperature	0 °F (-20 °F Capability)
Standard Suction Size	1.50 Inch NPT
Standard Discharge Size	1.00 Inch NPT
Fluid End Material	Cast Iron
Valve Types	Disc Valves, Ball Valves
Hydraulic Motor Mount	SAE B - 4 Bolt with 1.25"-14T SAE C - 4 Bolt with 1.25"-14T

### Performance Table

Pump Model	Piston Diameter (in)	Displacement (GAL/REV)	Maximum Pressure (PSI)	Pump Capacity (GPM) @ Input Speed (RPM)				
				350 RPM	625 RPM	700 RPM	750 RPM	890 RPM
Log13	1.625	0.0168	1,200	5.9	10.5	11.8	12.6	15.0
Log14	1.750	0.0195	1,000	6.8	12.2	13.7	14.6	17.4
Log18	2.250	0.0323	700	11.3	20.2	22.6	24.2	28.7

\* Horsepower based on 85 or 90% mechanical efficiency. Actual application horsepower requirements can be calculated using the equation: BHP = (GPM \* PSI) / (1714 \* 0.85 or 0.90)

\* Pump capacities shown are based on 100% volumetric efficiency.

\* Dimensions shown are for general sizing purposes and should not be used for construction. Contact FMC for actual dimensions of pump ordered.

\* FMC reserves the right to modify this information without prior notice.

## Log

### Cast Pump Engineering Dimensional Outline

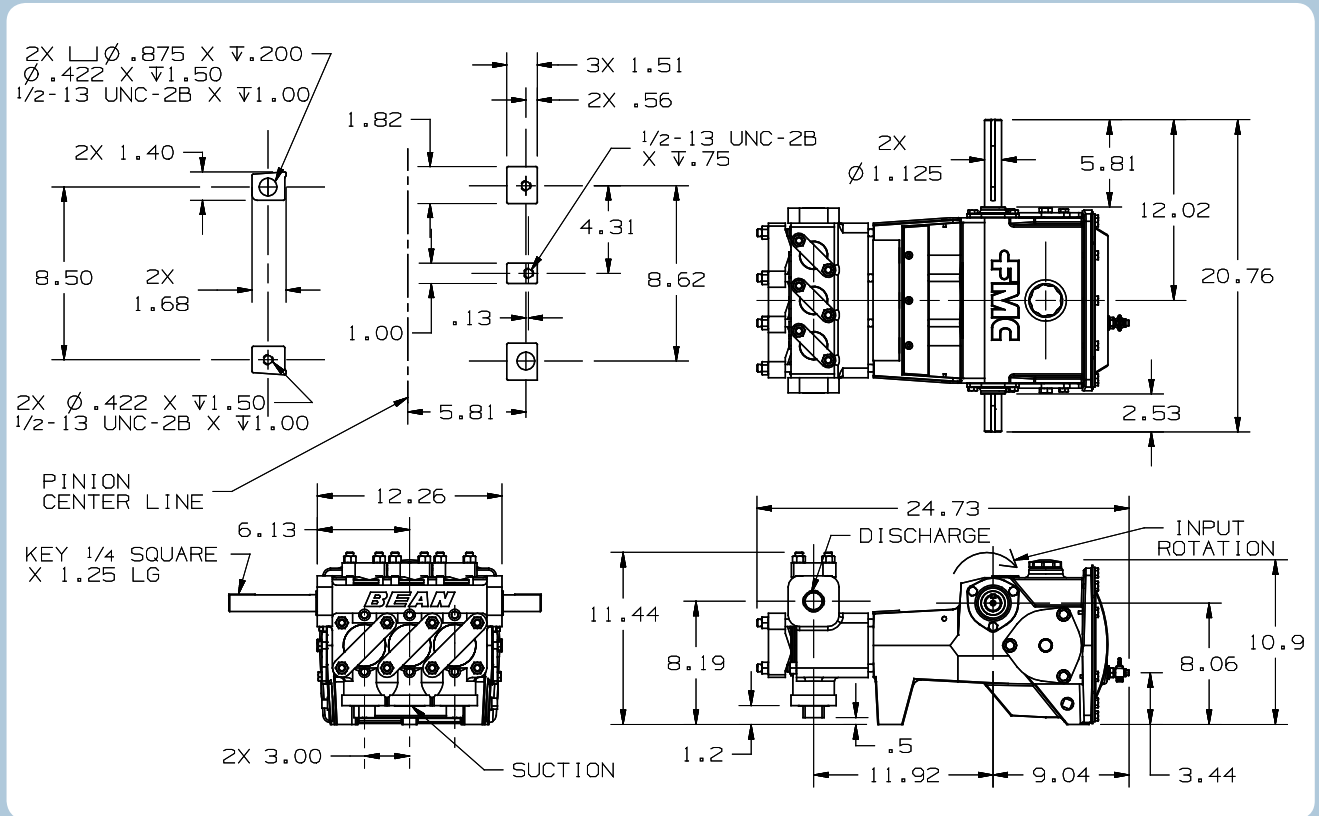

### Log NPSHr value for Standard Disc Valves

### Log NPSHr value for Standard Ball Valves

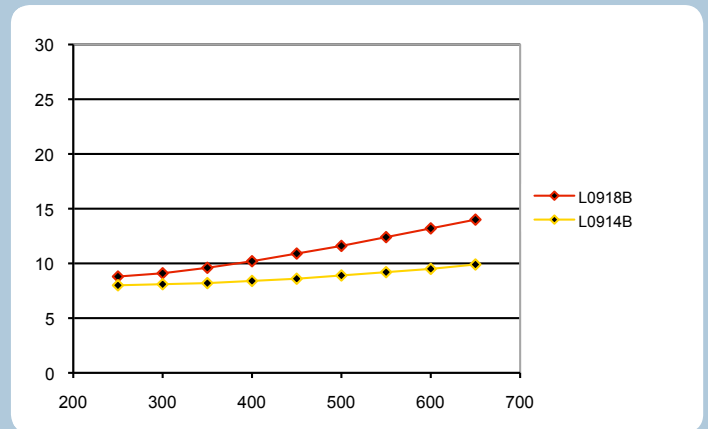
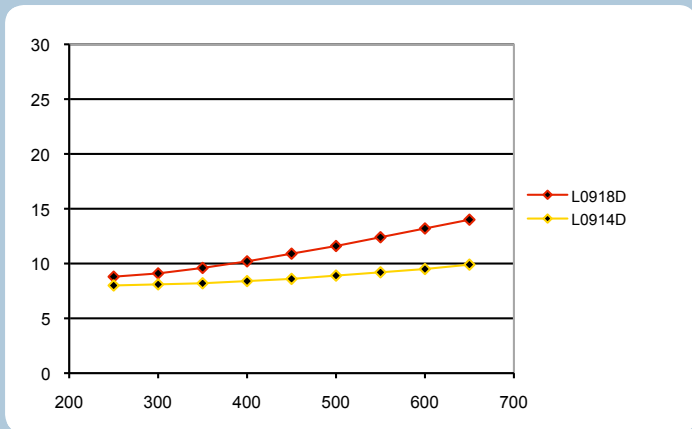

- FMC recommends NPSHa (available) exceeds NPSHr (required) by 5 feet of water.
- Take special consideration when calculating NPSHa. Recalculate NPSHa after pump model has been selected for more accurate values.
- NPSHr values are in feet of water. If you are pumping a different liquid than water, convert the required NPSH from water to the liquid being pumped by dividing the published NPSHr value by the specific gravity of the liquid being pumped.
- FMC published NPSHr values are based on test data collected on specific pumps at the factory and are estimated values. Actual NPSHr values for an ordered pump can only be determined by a factor test. For NPSH critical applications, contact the factory for additional information and request an NPSHr test performed on your pump before shipment.
- Pump drawing dimensions in inches.

## LogHV Piston Pump Data (High Volume)

22.6 BHP Continuous Duty (27.1 BHP Intermittent Duty)

### Log HV

Standard Cast ISO Drawing

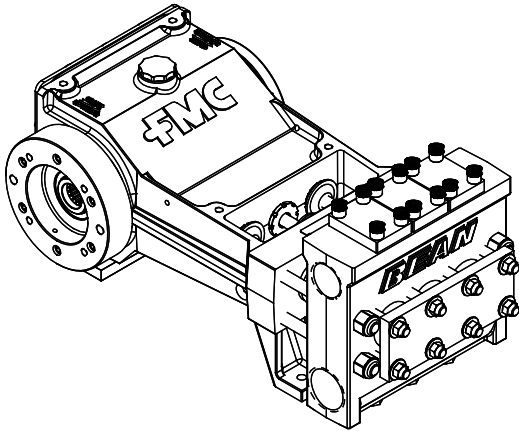

### Specifications

Pump Model	Log-HV
Configuration	Horizontal Triplex Piston
Number of Pistons	3
Stroke Length	2.25 Inches
Frame Load Rating	3,200 lbs
Pump Weight (Average)	325 lbs
Direction of Rotation	Top of shaft toward head
Internal Gear Ratio	NA
Intermittent Duty Speed Rating	450 RPM
Continuous Duty Speed Rating	375 RPM
Ball Valve Max Speed Rating	NA
Minimum Speed	100 RPM
Mechanical Efficiency	90%
Lubrication System (Standard)	Splash, Gravity Return
Lube Oil Capacity	2.25 Quarts
Lube Oil Type	SAE 30
Maximum Fluid Temperature	140 °F (250 °F Capability)
Minimum Fluid Temperature	0 °F (-20 °F Capability)
Standard Suction Size	HD - 2.00 Inch NPT HV - 2.50 Inch NPT
Standard Discharge Size	HD - 1.50 Inch NPT HV - 2.00 Inch NPT
Fluid End Material	Ductile Iron, Nickle Aluminum Bronze
Valve Types	Disc Valves, Abrasion Resistant (AR) Valves
Hydraulic Motor Mount	SAE B - 4 Bolt with 1.25"-14T SAE C - 4 Bolt with 1.25"-14T

### Performance Table

Pump Model	Piston Diameter (in)	Displacement (GAL/REV)	Maximum Pressure (PSI)	Pump Capacity (GPM) @ Input Speed (RPM)				
				100 RPM	200 RPM	300 RPM	375 RPM	450 RPM
Log13-HV	1.625	0.0606	1,500	6.1	12.1	18.2	22.7	27.3
Log14-HV	1.750	0.0703	1,300	7.0	14.1	21.1	26.4	31.6
Log18-HV	2.250	0.1162	800	11.6	23.2	34.9	43.6	52.3

\* Horsepower based on 85 or 90% mechanical efficiency. Actual application horsepower requirements can be calculated using the equation:  $BHP = (GPM * PSI) / (1714 * 0.85 \text{ or } 0.90)$

\* Pump capacities shown are based on 100% volumetric efficiency.

\* Dimensions shown are for general sizing purposes and should not be used for construction. Contact FMC for actual dimensions of pump ordered.

\* FMC reserves the right to modify this information without prior notice.

## Log HV

### Cast Pump Engineering Dimensional Outline

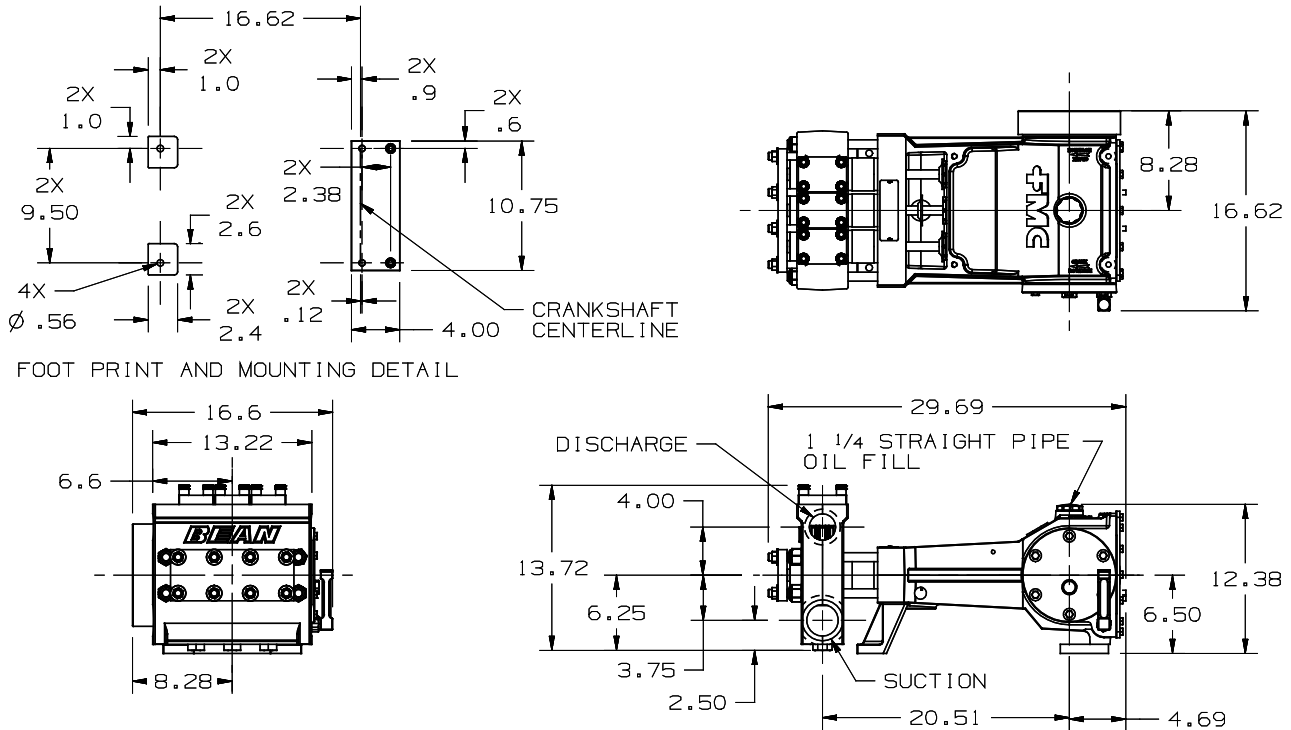

- FMC recommends NPSHa (available) exceeds NPSHr (required) by 5 feet of water.
- Take special consideration when calculating NPSHa. Recalculate NPSHa after pump model has been selected for more accurate values.
- NPSHr values are in feet of water. If you are pumping a different liquid than water, convert the required NPSH from water to the liquid being pumped by dividing the published NPSHr value by the specific gravity of the liquid being pumped.
- FMC published NPSHr values are based on test data collected on specific pumps at the factory and are estimated values. Actual NPSHr values for an ordered pump can only be determined by a factor test. For NPSH critical applications, contact the factory for additional information and request an NPSHr test performed on your pump before shipment.
- Pump drawing dimensions in inches.

# FMC Technologies

## W11 Piston Pump Data

30 BHP Continuous Duty (36 BHP Intermittent Duty)

### W11

Standard Cast ISO Drawing

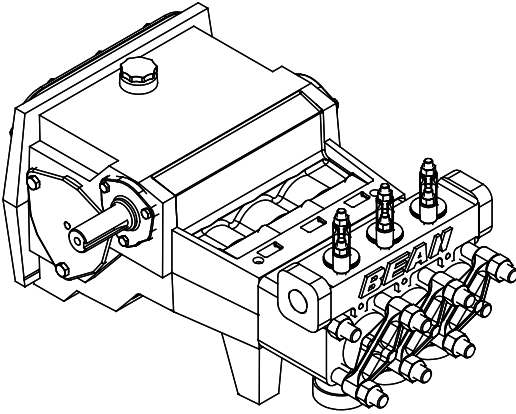

## Specifications

Pump Model	W11
Configuration	Horizontal Triplex Piston
Number of Pistons	3
Stroke Length	2.75 Inches
Frame Load Rating	6,000 lbs
Pump Weight (Average)	425 lbs
Direction of Rotation	Top of shaft away from head
Internal Gear Ratio	3.6:1
Intermittent Duty Speed Rating	900 RPM
Continuous Duty Speed Rating	750 RPM
Ball Valve Max Speed Rating	635 RPM
Minimum Speed *	360 RPM
Mechanical Efficiency	85%
Lubrication System (Standard)	Splash, Gravity Return
Lube Oil Capacity	1 Gallon
Lube Oil Type	SAE 30
Maximum Fluid Temperature	140 °F (250 °F Capability)
Minimum Fluid Temperature	0 °F (-20 °F Capability)
Standard Suction Size	2.00 Inch NPT
Standard Discharge Size	1.25 Inch NPT
Fluid End Material	Cast Iron
Valve Types	Disc Valves, Ball Valves
Hydraulic Motor Mount	SAE C - 2 Bolt with 1.25"-14T SAE C - 4 Bolt with 1.25"-14T

\* Slower RPM can be achieved with the addition of a pressurized lubrication system

## Performance Table

Pump Model	Piston Diameter (in)	Displacement (GAL/REV)	Maximum Pressure (PSI)	Pump Capacity (GPM) @ Input Speed (RPM)				
				350 RPM	500 RPM	635 RPM	750 RPM	900 RPM
W1118	2.250	0.0394	1,000	13.8	19.7	25.0	29.6	35.5
W1122	2.750	0.0589	1,000	20.6	29.5	37.4	44.2	53.0

\* Horsepower based on 85 or 90% mechanical efficiency. Actual application horsepower requirements can be calculated using the equation:  $BHP = (GPM * PSI) / (1714 * 0.85 \text{ or } 0.90)$

\* Pump capacities shown are based on 100% volumetric efficiency.

\* Dimensions shown are for general sizing purposes and should not be used for construction. Contact FMC for actual dimensions of pump ordered.

\* FMC reserves the right to modify this information without prior notice.

## W11

### Cast Pump Engineering Dimensional Outline

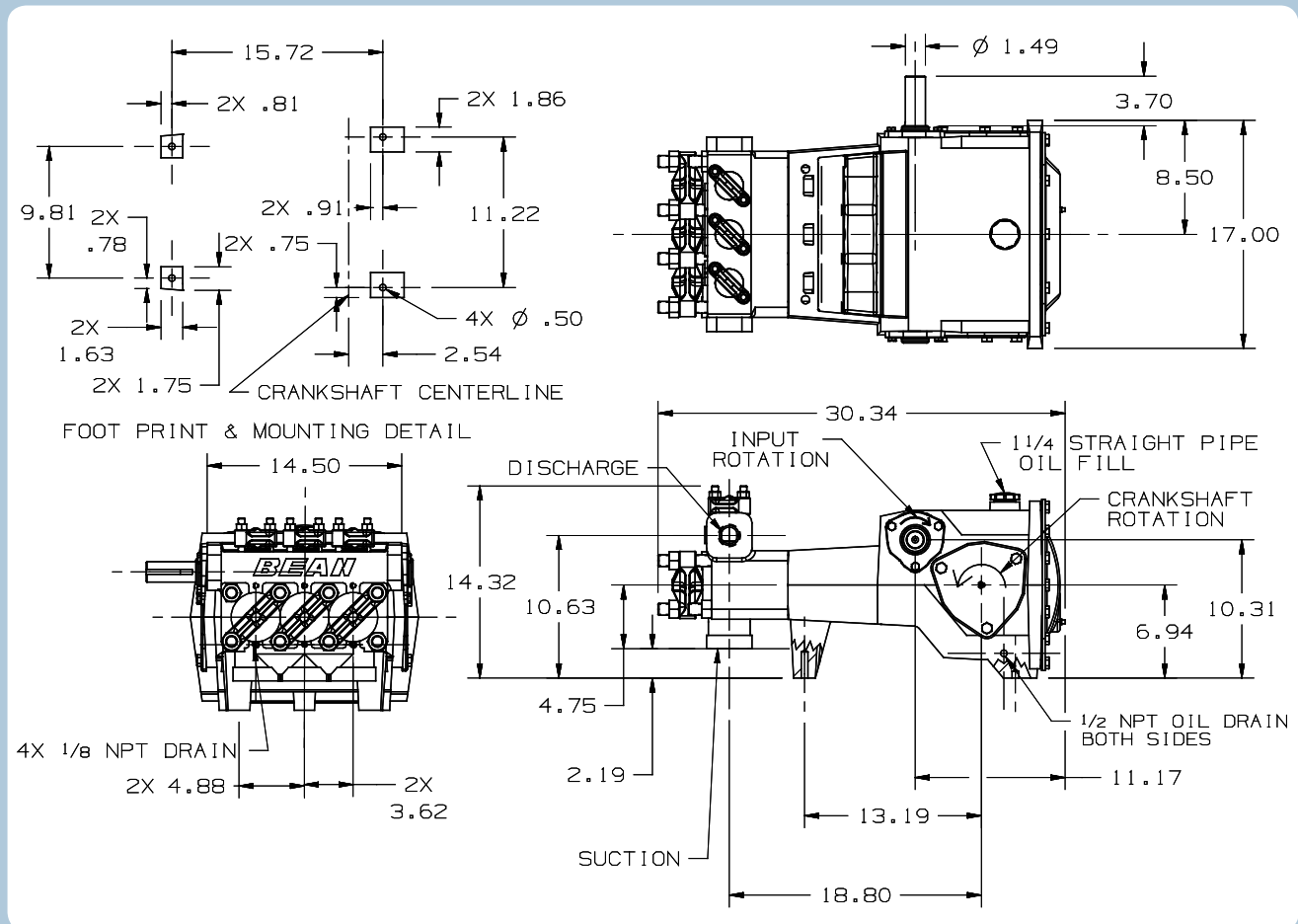

### W11 NPSHr value for Standard Disc Valves

### W11 NPSHr value for Standard Ball Valves

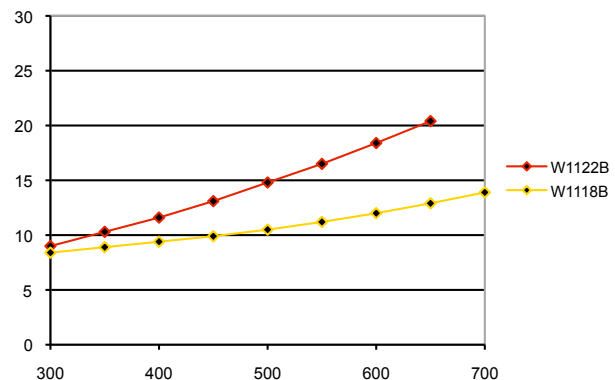
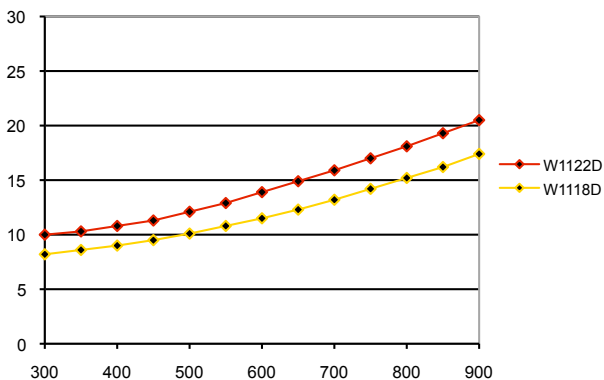

- FMC recommends NPSHa (available) exceeds NPSHr (required) by 5 feet of water.
- Take special consideration when calculating NPSHa. Recalculate NPSHa after pump model has been selected for more accurate values.
- NPSHr values are in feet of water. If you are pumping a different liquid than water, convert the required NPSH from water to the liquid being pumped by dividing the published NPSHr value by the specific gravity of the liquid being pumped.
- FMC published NPSHr values are based on test data collected on specific pumps at the factory and are estimated values. Actual NPSHr values for an ordered pump can only be determined by a factor test. For NPSH critical applications, contact the factory for additional information and request an NPSHr test performed on your pump before shipment.
- Pump drawing dimensions in inches.

## L11 Piston Pump Data

37 BHP Continuous Duty (52 BHP Intermittent Duty)

### L11

Standard Cast ISO Drawing

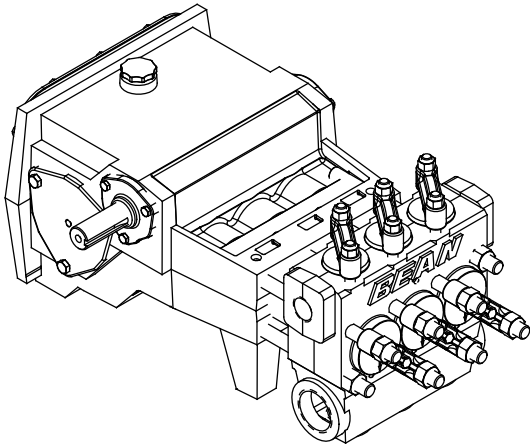

## Specifications

Pump Model	L11
Configuration	Horizontal Triplex Piston
Number of Pistons	3
Stroke Length	2.75 Inches
Frame Load Rating	6,000 lbs
Pump Weight (Average)	460 lbs
Direction of Rotation	Top of shaft away from head
Internal Gear Ratio	3.6:1
Intermittent Duty Speed Rating	1,275 RPM
Continuous Duty Speed Rating	900 RPM
Ball Valve Max Speed Rating	690 RPM
Minimum Speed *	360 RPM
Mechanical Efficiency	85%
Lubrication System (Standard)	Splash, Gravity Return
Lube Oil Capacity	1 Gallon
Lube Oil Type	SAE 30
Maximum Fluid Temperature	140 °F (250 °F Capability)
Minimum Fluid Temperature	0 °F (-20 °F Capability)
Standard Suction Size	2.50 Inch NPT
Standard Discharge Size	1.25 Inch NPT
Fluid End Material	Ductile Iron, Nickel Aluminum Bronze
Valve Types	Disc Valves, Ball Valves, Abrasion Resistant (AR) Valves
Hydraulic Motor Mount	SAE C - 2 Bolt with 1.25"-14T SAE C - 4 Bolt with 1.25"-14T

\* Slower RPM can be achieved with the addition of a pressurized lubrication system

## Performance Table

Pump Model	Piston Diameter (in)	Displacement (GAL/REV)	Maximum Pressure (PSI)	Pump Capacity (GPM) @ Input Speed (RPM)				
				350 RPM	690 RPM	800 RPM	900 RPM	1275 RPM
L1114	1.750	0.0239	2,500	8.4	16.5	19.1	21.5	30.4
L1118	2.250	0.0394	1,500	13.8	27.2	31.6	35.5	50.3
L1122	2.750	0.0589	1,000	20.6	40.7	47.1	53.0	75.1

\* Horsepower based on 85 or 90% mechanical efficiency. Actual application horsepower requirements can be calculated using the equation: BHP = (GPM \* PSI) / (1714 \* 0.85 or 0.90)

\* Pump capacities shown are based on 100% volumetric efficiency.

\* Dimensions shown are for general sizing purposes and should not be used for construction. Contact FMC for actual dimensions of pump ordered.

\* FMC reserves the right to modify this information without prior notice.

## L11 Cast Pump Engineering Dimensional Outline

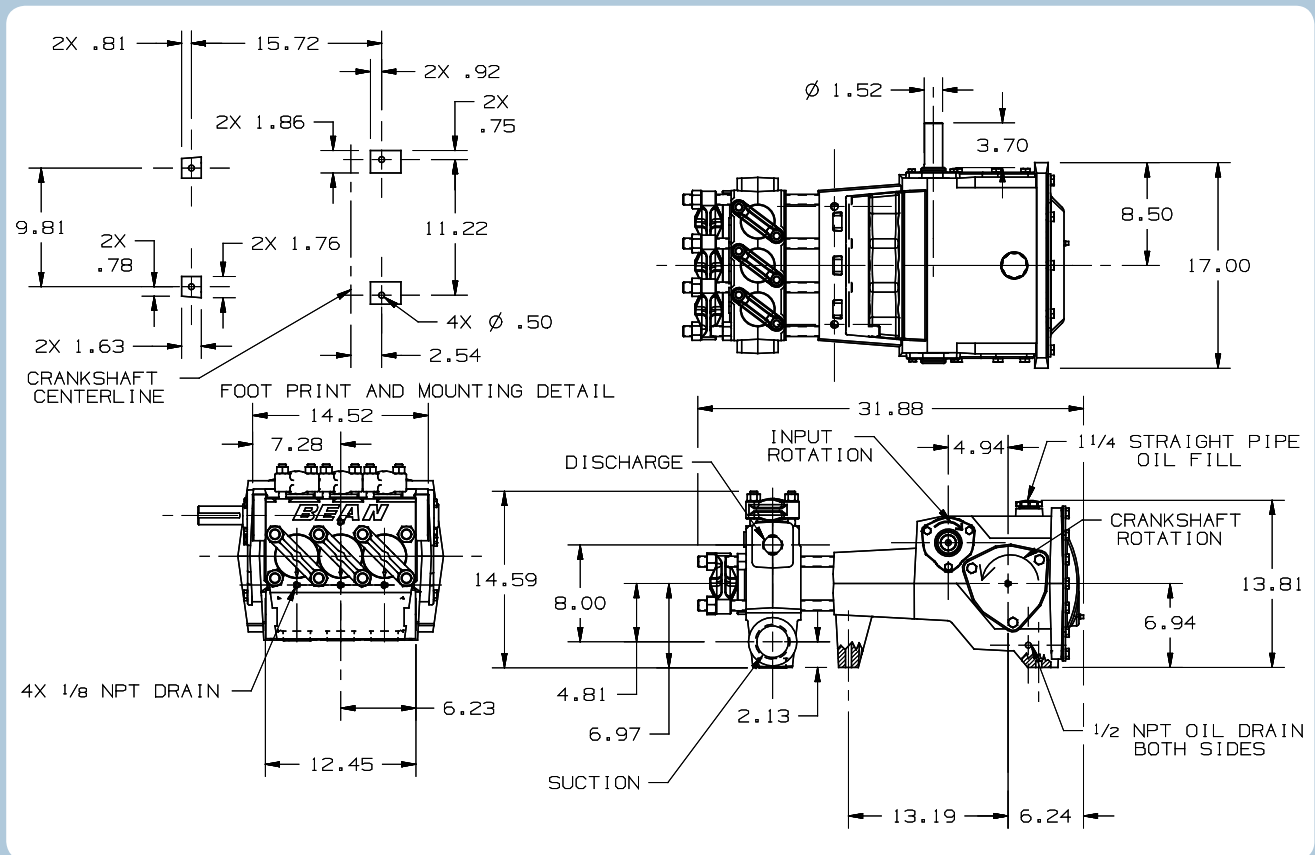

### L11 NPSHr value For Standard Disc Valves

### L11 NPSHr value For Standard Ball Valves

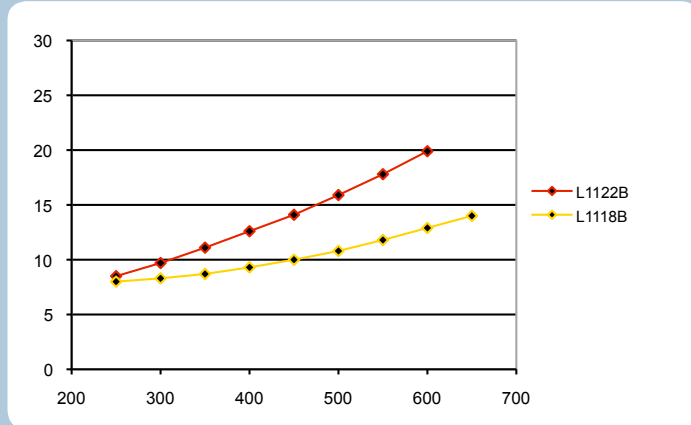
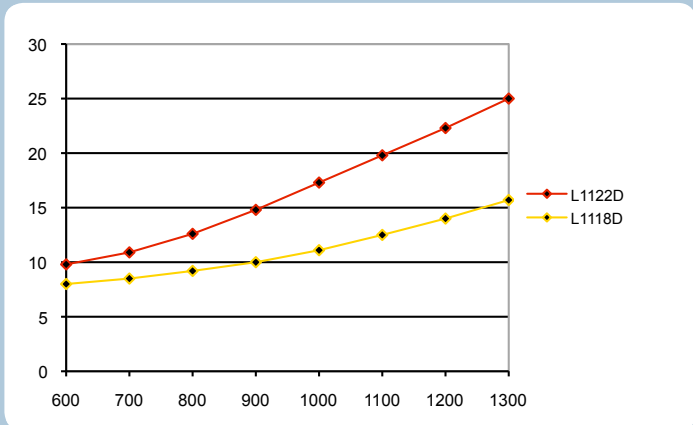

- FMC recommends NPSHa (available) exceeds NPSHr (required) by 5 feet of water.
- Take special consideration when calculating NPSHa. Recalculate NPSHa after pump model has been selected for more accurate values.
- NPSHr values are in feet of water. If you are pumping a different liquid than water, convert the required NPSH from water to the liquid being pumped by dividing the published NPSHr value by the specific gravity of the liquid being pumped.
- FMC published NPSHr values are based on test data collected on specific pumps at the factory and are estimated values. Actual NPSHr values for an ordered pump can only be determined by a factor test. For NPSH critical applications, contact the factory for additional information and request an NPSHr test performed on your pump before shipment.
- Pump drawing dimensions in inches.

## L16 Piston Pump Data

66 BHP Continuous Duty (87 BHP Intermittent Duty)

### L16

Standard Cast ISO Drawing

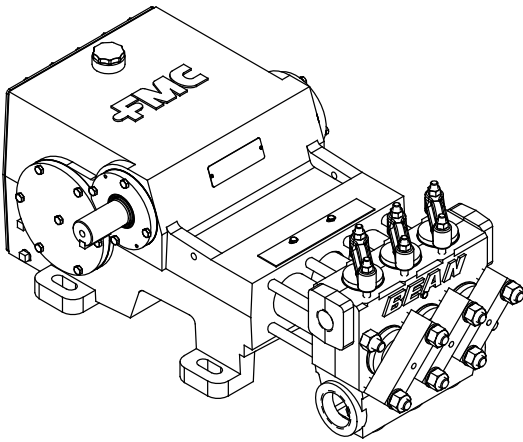

## Specifications

Pump Model	L16
Configuration	Horizontal Triplex Piston
Number of Pistons	3
Stroke Length	4.0 Inches
Frame Load Rating	6,600 lbs
Pump Weight (Average)	705 lbs
Direction of Rotation	Top of shaft away from head
Internal Gear Ratio	3.94:1
Intermittent Duty Speed Rating	1,450 RPM
Continuous Duty Speed Rating	1,100 RPM
Ball Valve Max Speed Rating	750 RPM
Minimum Speed *	394 RPM
Mechanical Efficiency	85%
Lubrication System (Standard)	Splash, Gravity Return
Lube Oil Capacity	10 Quarts
Lube Oil Type	SAE 80W90
Maximum Fluid Temperature	140 °F (250 °F Capability)
Minimum Fluid Temperature	0 °F (-20 °F Capability)
Standard Suction Size	STD - 2.50 Inch NPT HV - 3.00 Inch NPT
Standard Discharge Size	STD - 1.25 Inch NPT HV - 2.00 Inch NPT
Fluid End Material	Ductile Iron, Nickel Aluminum Bronze
Valve Types	Disc Valves, Ball Valves, Abrasion Resistant (AR) Valves
Hydraulic Motor Mount	SAE C - 2 Bolt with 1.25"-14T SAE C - 4 Bolt with 1.25"-14T

\* Slower RPM can be achieved with the addition of a pressurized lubrication system

STD = Standard Fluid Cylinder

HV = High Volume Fluid Cylinder

## Performance Table

Pump Model	Piston Diameter (in)	Displacement (GAL/REV)	Maximum Pressure (PSI)	Pump Capacity (GPM) @ Input Speed (RPM)				
				400 RPM	750 RPM	1000 RPM	1100 RPM	1450 RPM
L1614	1.750	0.0317	2,500	12.7	23.8	31.7	34.9	46.0
L1616	2.000	0.0414	2,100	16.6	31.1	41.4	45.6	60.1
L1618	2.250	0.0524	1,650	21.0	39.3	52.4	57.7	76.0
L1622	2.750	0.0783	1,100	31.3	58.7	78.3	86.1	113.6

\* Horsepower based on 85 or 90% mechanical efficiency. Actual application horsepower requirements can be calculated using the equation:  
 $BHP = (GPM * PSI) / (1714 * 0.85 \text{ or } 0.90)$

\* Pump capacities shown are based on 100% volumetric efficiency.

\* Dimensions shown are for general sizing purposes and should not be used for construction. Contact FMC for actual dimensions of pump ordered.

\* FMC reserves the right to modify this information without prior notice.

## L16

### Cast Pump Engineering Dimensional Outline

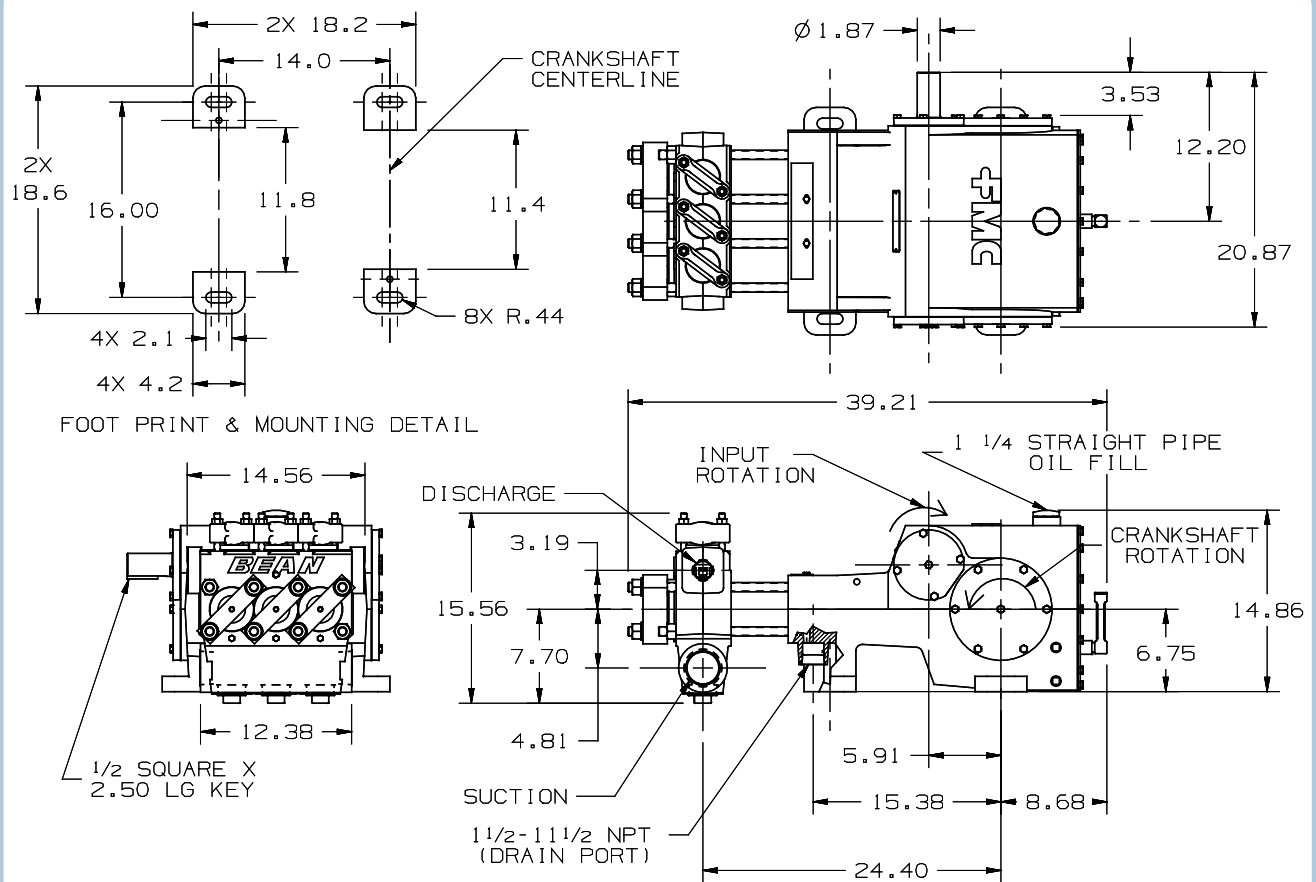

- FMC recommends NPSHa (available) exceeds NPSHr (required) by 5 feet of water.
- Take special consideration when calculating NPSHa. Recalculate NPSHa after pump model has been selected for more accurate values.
- NPSHr values are in feet of water. If you are pumping a different liquid than water, convert the required NPSH from water to the liquid being pumped by dividing the published NPSHr value by the specific gravity of the liquid being pumped.
- FMC published NPSHr values are based on test data collected on specific pumps at the factory and are estimated values. Actual NPSHr values for an ordered pump can only be determined by a factor test. For NPSH critical applications, contact the factory for additional information and request an NPSHr test performed on your pump before shipment.
- Pump drawing dimensions in inches.

# Plunger pumps

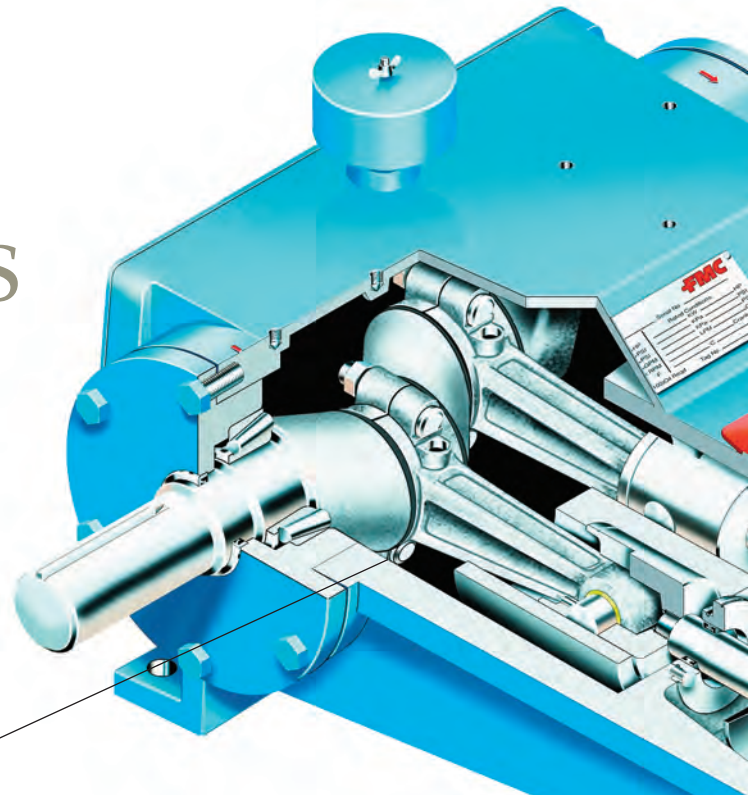

Durable Power Ends are designed to provide years of service life. Heavy-duty design features include oversized bearings, precision crafted components, and a reliable splash- lubrication system. Pressure oil lube, oil level monitoring, heating and cooling systems can be added as options.

Braided Compression Packing made from aramid and PTFE fibers provides excellent overall performance. External lubrication is not required but can be added as an option to extend packing life in many applications. Numerous additional packing styles or materials can be supplied to provide optimal performance in any service.

FMC Technologies plunger pumps are an excellent choice for the most demanding applications. Extremely versatile FMC Technologies plunger pumps can be readily adapted for optimum performance in a wide range of service conditions. Pumps are available in ductile iron, carbon steel, alloy steel, aluminum bronze, duplex stainless steel, Inconel®, and other materials as required.

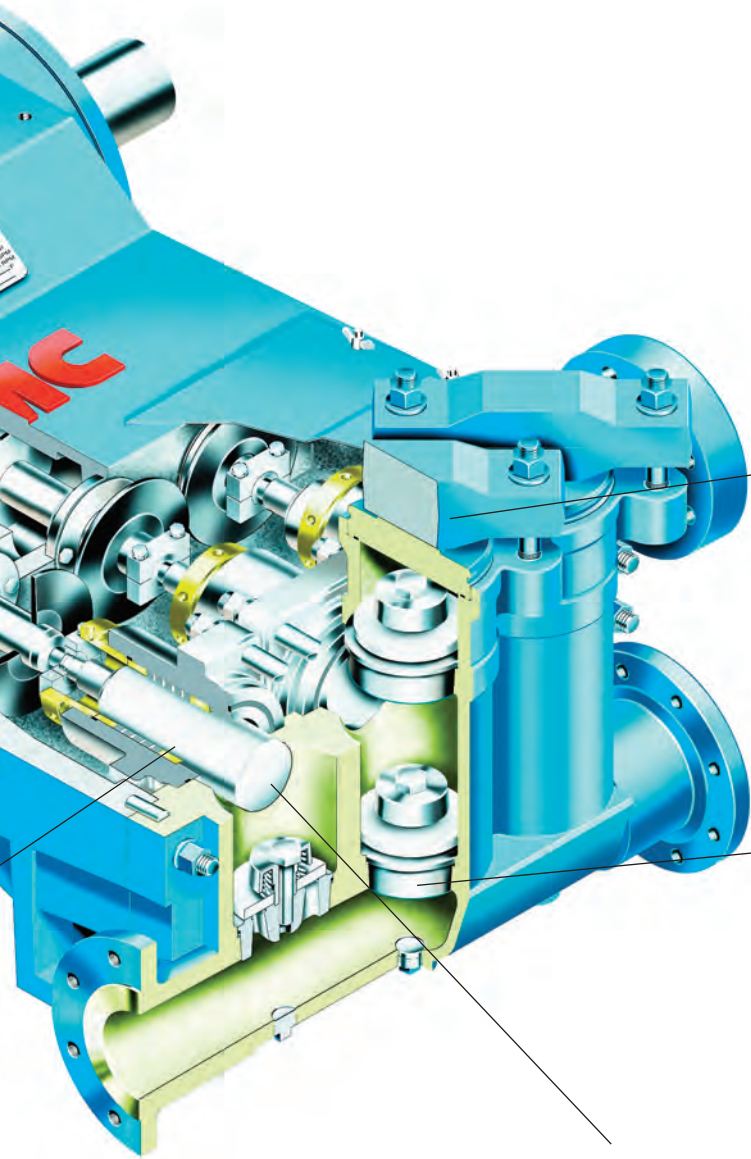

Fluid End wetted parts can be supplied in a wide variety of cast or forged materials.

Standard Disc Valves provide quiet, efficient performance in most applications. Abrasion-resistant valves are available to suit high-performance applications.

Hard-Coated Plungers provide the best combination of value, performance, and corrosion resistance for most applications. Ceramic, tungsten carbide, or other styles are also available.

All pumps have been carefully designed to provide years of operational life. Heavy-duty designs with oversized bearings ensure these pumps will deliver value and performance in real world operating conditions. When maintenance is required, FMC Technologies pumps feature easy access to typical service areas.

FMC Technologies plunger pumps have an outstanding record of dependable service in thousands of installations around the world. This success stems from the ability to combine sound engineering, reliable craftsmanship, and years of pumping experience.

## Do4 Plunger Pump Data

2.7 BHP Continuous Duty (3.2 BHP Intermittent Duty)

### Forged ISO Drawing

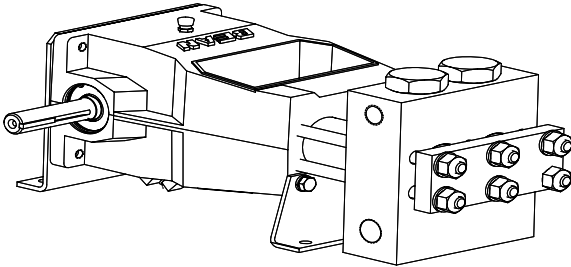

### Specifications

Pump Model	Do4
Design Standard	API-674, Second Edition
Configuration	Horizontal Duplex Plunger
Number of Plungers	2
Stroke Length	1.0 Inches
Frame Load Rating	950 lbs
Forged Fluid Cylinder Pressure Rating	2,500 psi
Cast Fluid Cylinder Pressure Rating	Not Available
Pump Weight (Average)	75 lbs
Intermittent Duty Speed Rating	600 RPM
Continuous Duty Speed Rating	500 RPM
API-674 Max Recommended Speed	500 RPM
Minimum Speed *	100 RPM
Mechanical Efficiency	90%
Lubrication System (Standard)	Splash, Gravity Return
Lubrication System (Optional)	Pressurized, Motor Driven
Lube Oil Capacity	1 Quarts
Lube Oil Type	SAE 30
Maximum Fluid Temperature	200 °F (400 °F Capability)
Minimum Fluid Temperature	-20 °F (-50 °F Capability)
Valve Types	Disc Valves, Abrasion Resistant Valves

\* Slower RPM can be achieved with the addition of a pressurized lubrication system

Forged Fluid End Material	Cast Fluid End Material
A105 Carbon Steel	Not Available
A350-LF2 Carbon Steel	
316L Stainless Steel	
2205 Duplex Stainless Steel	

\* Special Materials available on request

Standard Connection Sizes	Suction	Discharge
M0408	0.75	0.50

- Consult FMC for specific exceptions to API-674 and NACE standards.
- Consult FMC for any application where inlet pressures will exceed 10% of rated discharge pressure.
- Horsepower based on 90% mechanical efficiency. Actual application horsepower requirements can be calculated using the equation:  $BHP = (GPM * PSI) / (1714 * 0.90)$
- Direction of rotation is the top of the crankshaft towards the fluid head.



## Mo6 Plunger Pump Data

16.6 BHP Continuous Duty (20.9 BHP Intermittent Duty)

### Forged ISO Drawing

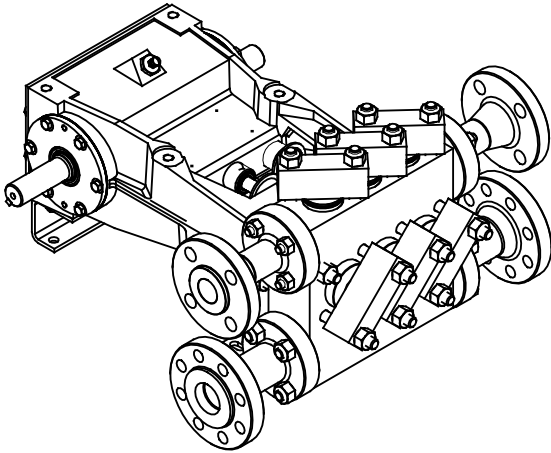

### Cast ISO Drawing

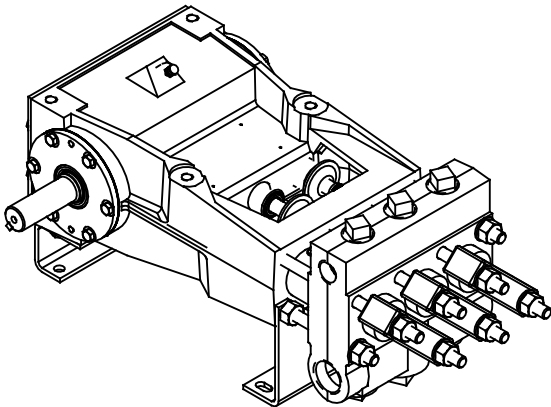

### Specifications

Pump Model	Mo6
Design Standard	API-674, Second Edition
Configuration	Horizontal Triplex Plunger
Number of Plungers	3
Stroke Length	1.5 Inches
Frame Load Rating	2,700 lbs
Forged Fluid Cylinder Pressure Rating	10,000 psi
Cast Fluid Cylinder Pressure Rating	3,000 psi
Pump Weight (Average)	245 lbs
Intermittent Duty Speed Rating	600 RPM
Continuous Duty Speed Rating	475 RPM
API-674 Max Recommended Speed	475 RPM
Minimum Speed *	100 RPM
Mechanical Efficiency	90%
Lubrication System (Standard)	Splash, Gravity Return
Lubrication System (Optional)	Pressurized, Motor Driven
Lube Oil Capacity	2 Quarts
Lube Oil Type	SAE 30
Maximum Fluid Temperature	200 °F (400 °F Capability)
Minimum Fluid Temperature	-20 °F (-50 °F Capability)
Valve Types	Disc Valves, Abrasion Resistant Valves

\* Slower RPM can be achieved with the addition of a pressurized lubrication system

Forged Fluid End Material	Cast Fluid End Material
A105 Carbon Steel	Ductile Iron
A350-LF2 Carbon Steel	Nickel Aluminum Bronze
316L Stainless Steel	316L Stainless Steel
2205 Duplex Stainless Steel	2205 Duplex Stainless Steel

\* Special Materials available on request

Standard Connection Sizes	Suction	Discharge
Mo604-Mo607	1.5	0.75
Mo608-Mo615	1.5	1.0
Mo608-Mo615 HV	2.0	1.5

\* NPT Connections Available

- Consult FMC for specific exceptions to API-674 and NACE standards.
- Consult FMC for any application where inlet pressures will exceed 10% of rated discharge pressure.
- Horsepower based on 90% mechanical efficiency. Actual application horsepower requirements can be calculated using the equation:  $BHP = (GPM * PSI) / (1714 * 0.90)$
- Direction of rotation is the top of the crankshaft towards the fluid head.

## Mo6 Performance Table

Pump Model	Plunger Diameter (in)	Displacement (GAL/REV)	Maximum Pressure (PSI)	Pump Capacity (GPM) @ Input Speed (RPM)						
				100 RPM	200 RPM	300RPM	400RPM	475RPM	500RPM	600RPM
Mo604	0.500	0.0038	10,000	0.4	0.8	1.1	1.5	1.8	1.9	2.3
Mo605	0.625	0.0060	8,800	0.6	1.2	1.8	2.4	2.9	3.0	3.6
Mo606	0.750	0.0086	6,100	0.9	1.7	2.6	3.4	4.1	4.3	5.2
Mo608	1.000	0.0153	3,400	1.5	3.1	4.6	6.1	7.3	7.7	9.2
Mo610	1.250	0.0239	2,200	2.4	4.8	7.2	9.6	11.4	12.0	14.3
Mo612	1.500	0.0344	1,500	3.4	6.9	10.3	13.8	16.3	17.2	20.6
Mo614	1.750	0.0469	1,120	4.7	9.4	14.1	18.8	22.3	23.5	28.1
Mo615	1.875	0.0538	1,000	5.4	10.8	16.1	21.5	25.6	26.9	32.3

### Mo6 NPSHr values for Disc Valves with 1-spring (Standard Stiffness)

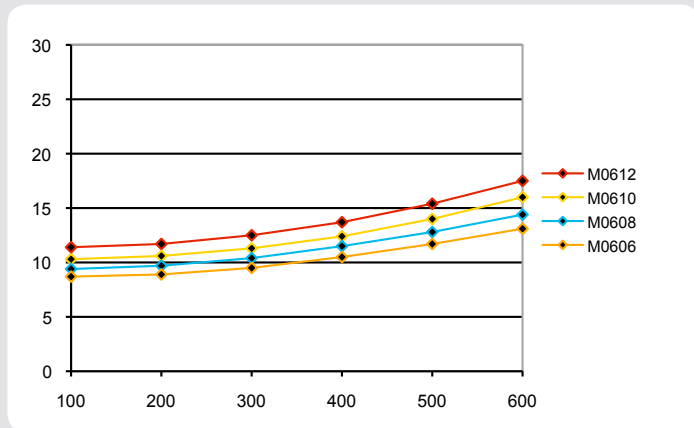

### Mo612 NPSHr values for Disc Valves with 1-spring (Large Flow Valves)

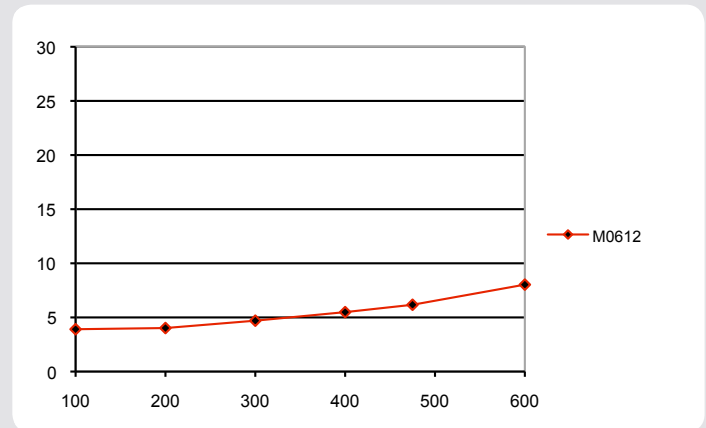

### Mo615 NPSHr values for Disc Valves with 1-spring

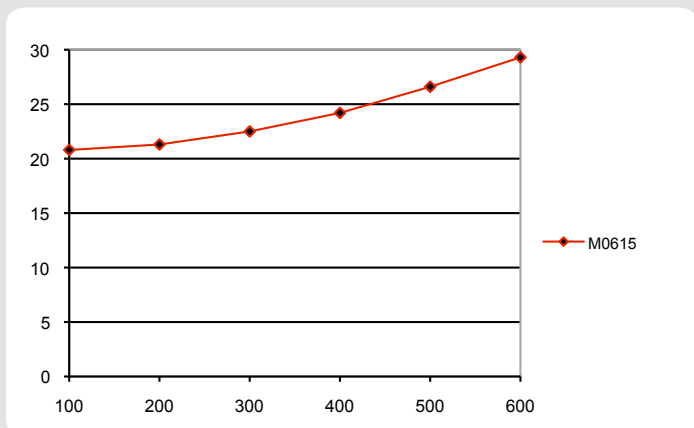

#### Mo606 - Mo612

Standard Disc Valve Spring = 5262783

#### Mo606 - Mo612

Stiff Disc Valve Spring = 5264908 (add 5 ft. to NPSH values)

- Pump capacities shown are based on 100% volumetric efficiency.
- FMC recommends NPSHa (available) exceeds NPSHr (required) by 5 feet of water.
- Take special consideration when calculating NPSHa. Recalculate NPSHa after pump model has been selected for more accurate values.
- NPSHr values are in feet of water. If you are pumping a different liquid than water, convert the required NPSH from water to the liquid being pumped by dividing the published NPSHr value by the specific gravity of the liquid being pumped.
- FMC published NPSHr values are based on test data collected on specific pumps at the factory and are estimated values. Actual NPSHr values for an ordered pump can only be determined by a factor test. For NPSH critical applications, contact the factory for additional information and request an NPSHr test performed on your pump before shipment.

## Mo6 Plunger Pump Data

16.6 BHP Continuous Duty (20.9 BHP Intermittent Duty)

### Forged Pump Engineering Dimensional Outline

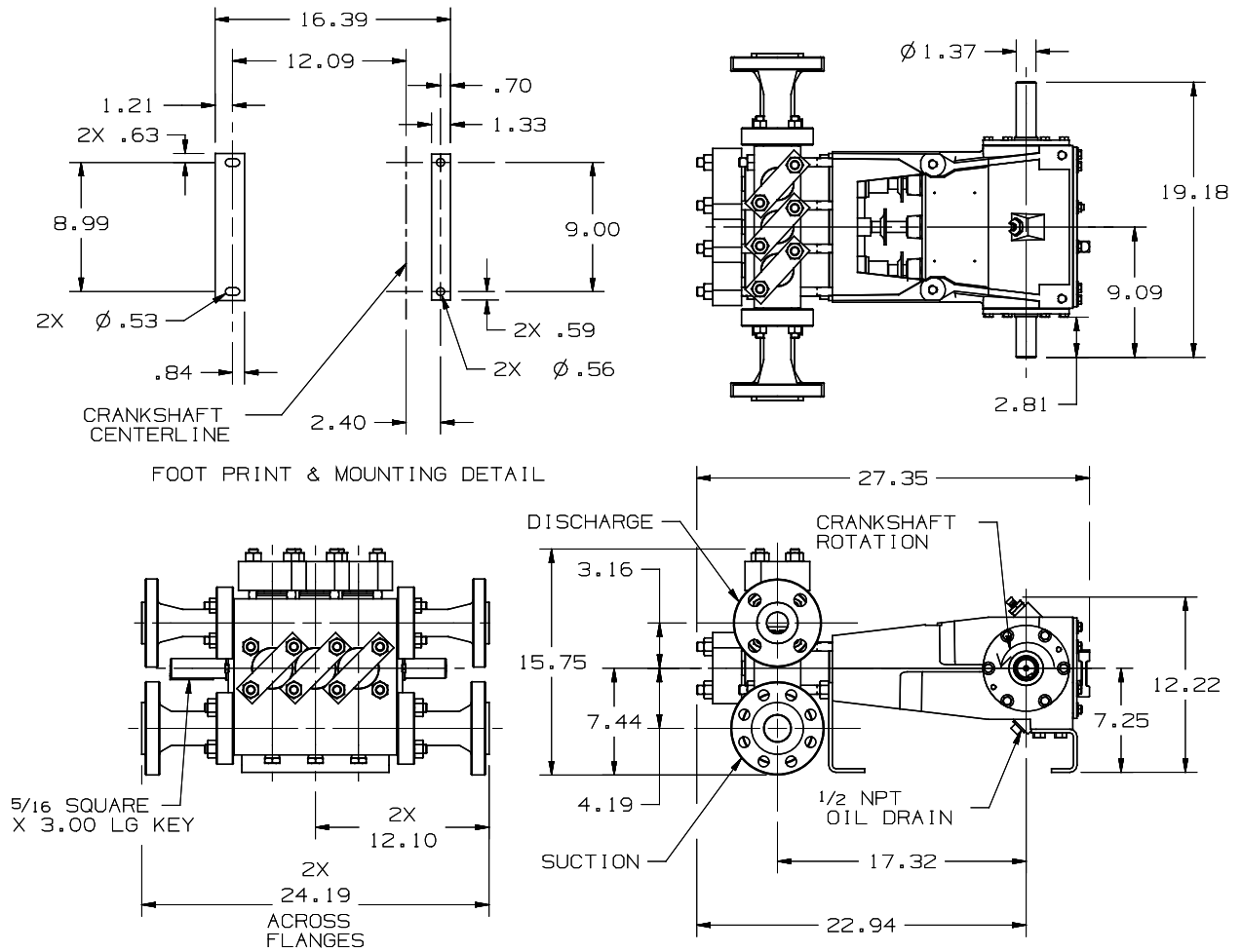

## Mo6 Plunger Pump Data

16.6 BHP Continuous Duty (20.9 BHP Intermittent Duty)

### Cast Pump Engineering Dimensional Outline

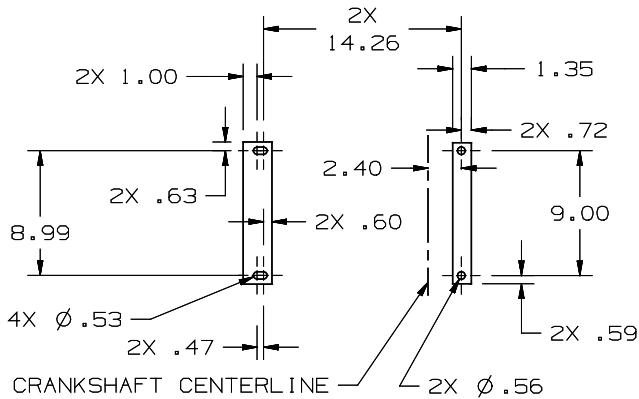

FOOT PRINT & MOUNTING DETAIL

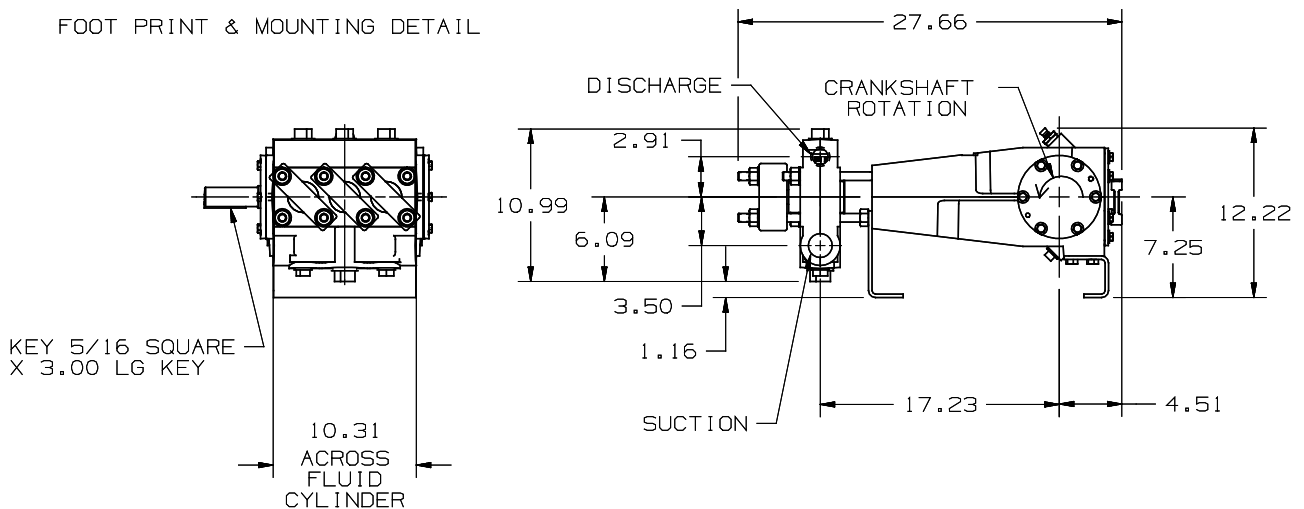
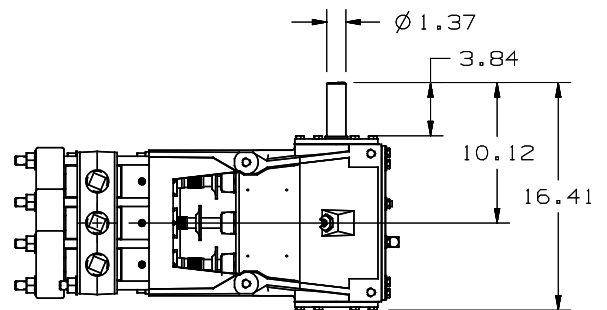

• Dimensions shown are for general sizing purposes and should not be used of construction. Contact FMC for actual dimensions of pump ordered.

• FMC reserves the right to modify this information without prior notice.

• Pump drawing dimensions in inches.

## Mo8 Plunger Pump Data

34 BHP Continuous Duty (45 BHP Intermittent Duty)

### Forged ISO Drawing

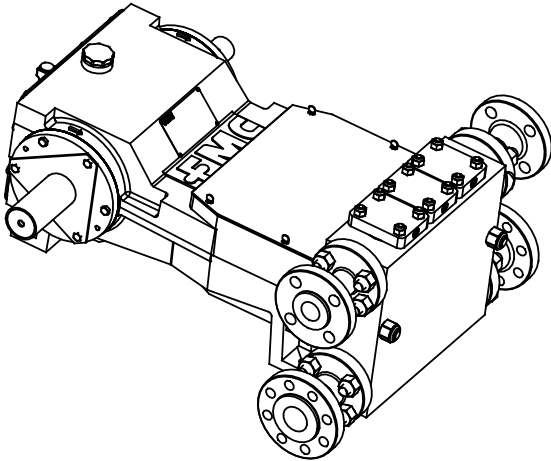

### Cast ISO Drawing

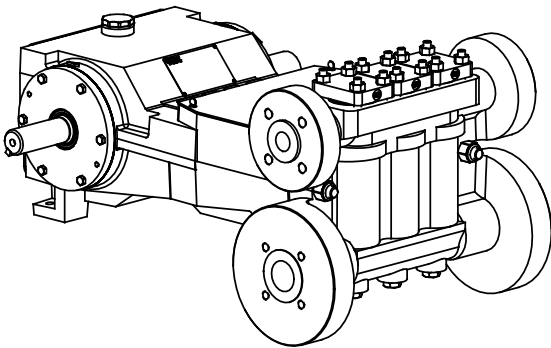

### Specifications

Pump Model	Mo8
Design Standard	API-674, Second Edition
Configuration	Horizontal Triplex Plunger
Number of Plungers	3
Stroke Length	2.0 Inches
Frame Load Rating	4,450 lbs
Forged Fluid Cylinder Pressure Rating	10,000 psi
Cast Fluid Cylinder Pressure Rating	3,000 psi
Pump Weight (Average)	550 lbs
Intermittent Duty Speed Rating	600 RPM
Continuous Duty Speed Rating	450 RPM
API-674 Max Recommended Speed	450 RPM
Minimum Speed *	100 RPM
Mechanical Efficiency	90%
Lubrication System (Standard)	Splash, Gravity Return
Lubrication System (Optional)	Pressurized, Motor Driven
Lube Oil Capacity	1.5 Gallons
Lube Oil Type	SAE 30
Maximum Fluid Temperature	200 °F (400 °F Capability)
Minimum Fluid Temperature	-20 °F (-50 °F Capability)
Valve Types	Disc Valves, Abrasion Resistant Valves

\* Slower RPM can be achieved with the addition of a pressurized lubrication system

Forged Fluid End Material	Cast Fluid End Material
A105 Carbon Steel	Ductile Iron
A350-LF2 Carbon Steel	Nickel Aluminum Bronze
316L Stainless Steel	316L Stainless Steel
2205 Duplex Stainless Steel	2205 Duplex Stainless Steel

\* Special Materials available on request

Standard Connection Sizes	Suction	Discharge
Mo806-Mo808	1.5	0.75
Mo809-Mo820	2.0	1.5
Mo815-Mo820	2.5	1.5

\* NPT Connections Available

- Consult FMC for specific exceptions to API-674 and NACE standards.
- Consult FMC for any application where inlet pressures will exceed 10% of rated discharge pressure.
- Horsepower based on 90% mechanical efficiency. Actual application horsepower requirements can be calculated using the equation:  $BHP = (GPM * PSI) / (1714 * 0.90)$
- Direction of rotation is the top of the crankshaft towards the fluid head.

## Mo8 Performance Table

Pump Model	Plunger Diameter (in)	Displacement (GAL/REV)	Maximum Pressure (PSI)	Pump Capacity (GPM) @ Input Speed (RPM)						
				100 RPM	200 RPM	300RPM	400RPM	450RPM	500RPM	600RPM
Mo806	0.750	0.0115	10,000	1.2	2.3	3.5	4.6	5.2	5.8	6.9
Mo807	0.875	0.0156	7,400	1.6	3.1	4.7	6.2	7.0	7.8	9.4
Mo808	1.000	0.0204	5,650	2.0	4.1	6.1	8.2	9.2	10.2	12.2
Mo810	1.250	0.0319	3,620	3.2	6.4	9.6	12.8	14.4	16.0	19.1
Mo812	1.500	0.0459	2,520	4.6	9.2	13.8	18.4	20.7	23.0	27.5
Mo814	1.750	0.0625	1,850	6.3	12.5	18.8	25.0	28.1	31.3	37.5
Mo816	2.000	0.0816	1,420	8.2	16.3	24.5	32.6	36.7	40.8	49.0
Mo818	2.250	0.1033	1,120	10.3	20.7	31	41.3	46.5	51.7	62.0
Mo820	2.500	0.1275	915	12.8	25.5	38.3	51.0	57.4	63.8	76.5

### Mo8 NPSHr values for Disc Valves with 2-springs

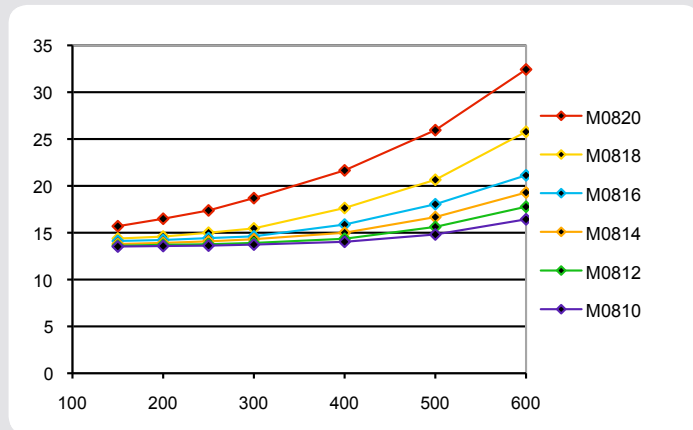

### Mo8 NPSHr values for AR Valves with 1-spring

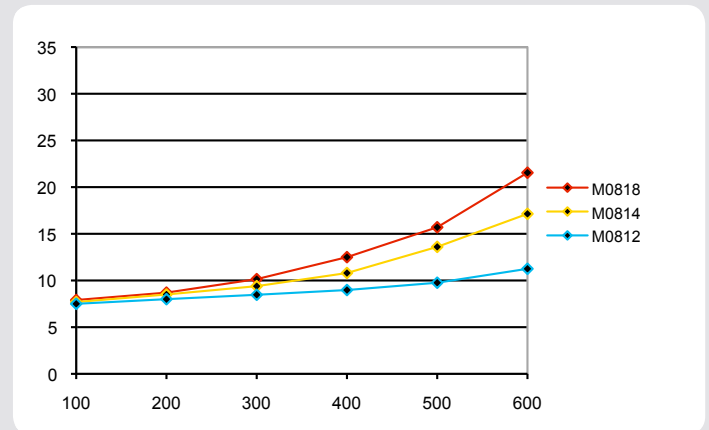

### Mo8 NPSHr values for Disc Valves with 1-spring

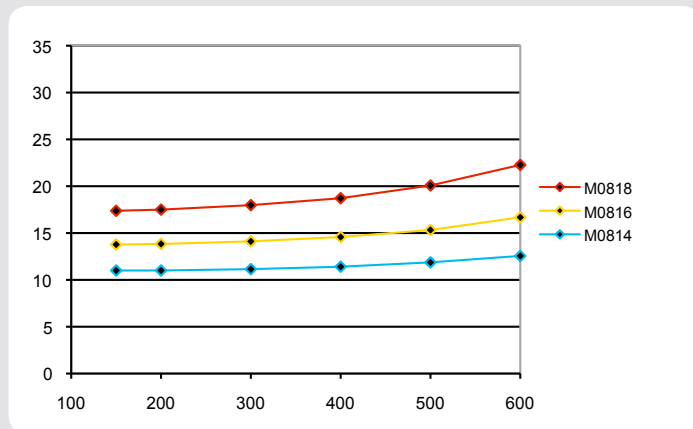

#### Mo810 - Mo820

Stiff Disc Valve Springs = 5263970 and 5263971

#### Mo810 - Mo820

Standard Disc Valve Spring = 5263970

- Pump capacities shown are based on 100% volumetric efficiency.
- FMC recommends NPSHa (available) exceeds NPSHr (required) by 5 feet of water.
- Take special consideration when calculating NPSHa. Recalculate NPSHa after pump model has been selected for more accurate values.
- NPSHr values are in feet of water. If you are pumping a different liquid than water, convert the required NPSH from water to the liquid being pumped by dividing the published NPSHr value by the specific gravity of the liquid being pumped.
- FMC published NPSHr values are based on test data collected on specific pumps at the factory and are estimated values. Actual NPSHr values for an ordered pump can only be determined by a factor test. For NPSH critical applications, contact the factory for additional information and request an NPSHr test performed on your pump before shipment.

## Mo8 Plunger Pump Data

34 BHP Continuous Duty (45 BHP Intermittent Duty)

### Forged Pump Engineering Dimensional Outline

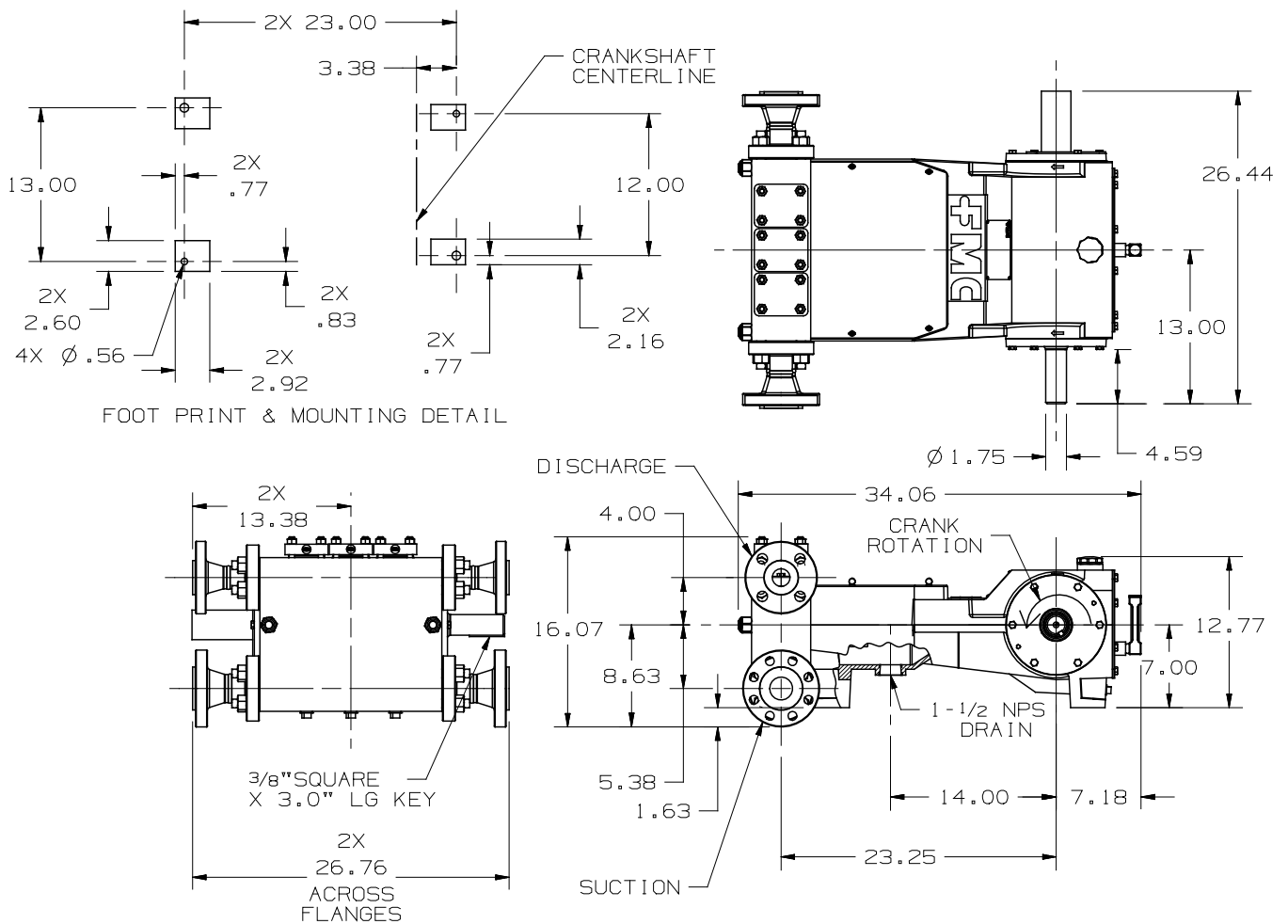

## Mo8 Plunger Pump Data

34 BHP Continuous Duty (45 BHP Intermittent Duty)

### Cast Pump Engineering Dimensional Outline

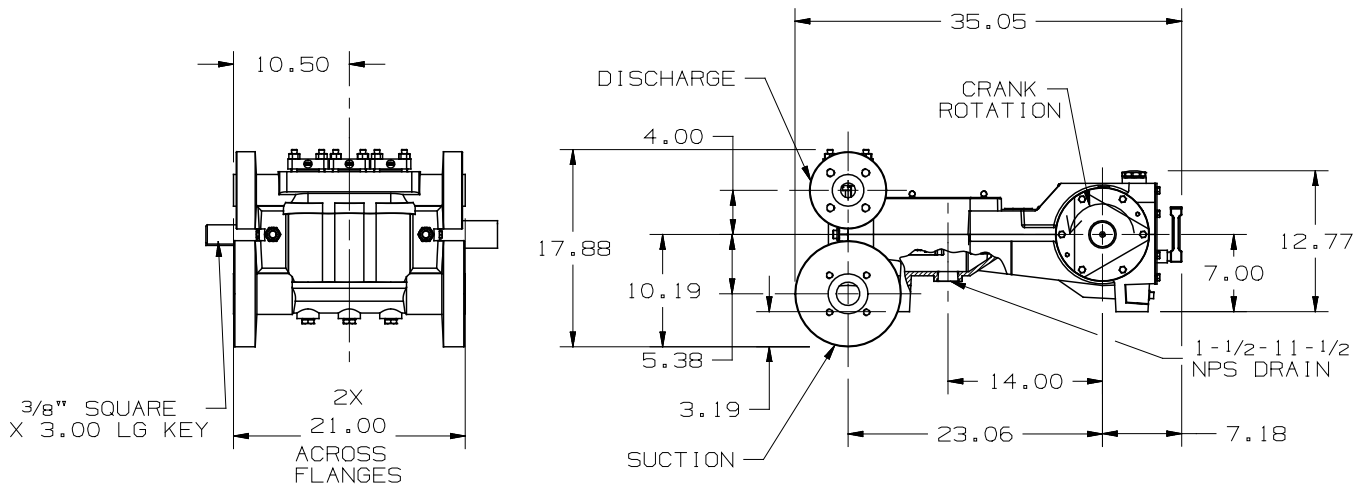
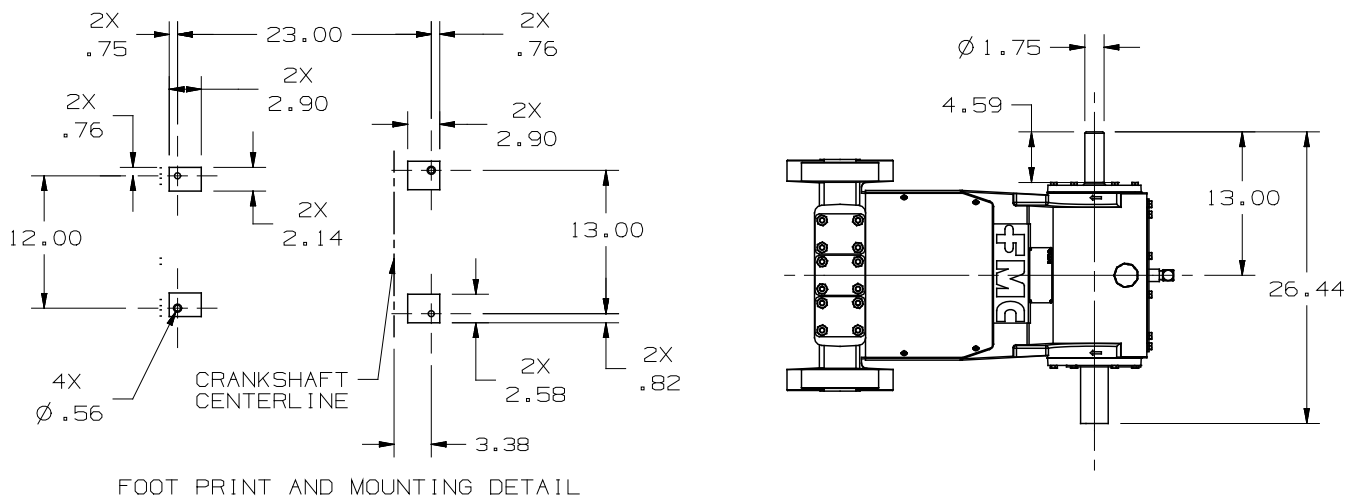

• Dimensions shown are for general sizing purposes and should not be used of construction. Contact FMC for actual dimensions of pump ordered.

• FMC reserves the right to modify this information without prior notice.

• Pump drawing dimensions in inches.

## M12 Plunger Pump Data

62 BHP Continuous Duty (77 BHP Intermittent Duty)

### Forged ISO Drawing

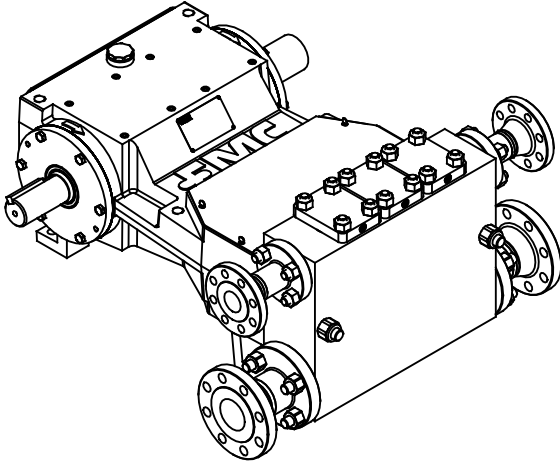

### Cast ISO Drawing

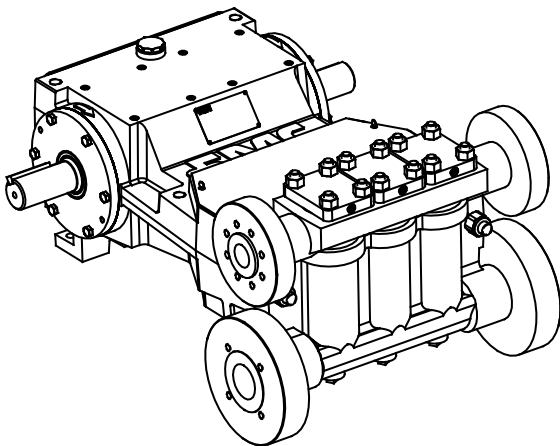

### Specifications

Pump Model	M12
Design Standard	API-674, Second Edition
Configuration	Horizontal Triplex Plunger
Number of Plungers	3
Stroke Length	3.0 Inches
Frame Load Rating	6,000 lbs
Forged Fluid Cylinder Pressure Rating	10,000 psi
Cast Fluid Cylinder Pressure Rating	3,000 psi
Pump Weight (Average)	950 lbs
Intermittent Duty Speed Rating	500 RPM
Continuous Duty Speed Rating	400 RPM
API-674 Max Recommended Speed	400 RPM
Minimum Speed *	100 RPM
Mechanical Efficiency	90%
Lubrication System (Standard)	Splash, Gravity Return
Lubrication System (Optional)	Pressurized, Motor Driven
Lube Oil Capacity	3 Gallons
Lube Oil Type	SAE 30
Maximum Fluid Temperature	200 °F (400 °F Capability)
Minimum Fluid Temperature	-20 °F (-50 °F Capability)
Valve Types	Disc Valves, Abrasion Resistant Valves

\* Slower RPM can be achieved with the addition of a pressurized lubrication system

Forged Fluid End Material	Cast Fluid End Material
A105 Carbon Steel	Ductile Iron
A350-LF2 Carbon Steel	Nickel Aluminum Bronze
316L Stainless Steel	316L Stainless Steel
2205 Duplex Stainless Steel	2205 Duplex Stainless Steel

\* Special Materials available on request

Standard Connection Sizes	Suction	Discharge
M1207-M1211	2.0	1.0
M1209-M1216	3.0	1.5
M1212-M1226	3.0	2.0

\* NPT Connections Available

- Consult FMC for specific exceptions to API-674 and NACE standards.
- Consult FMC for any application where inlet pressures will exceed 10% of rated discharge pressure.
- Horsepower based on 90% mechanical efficiency. Actual application horsepower requirements can be calculated using the equation:  $BHP = (GPM * PSI) / (1714 * 0.90)$
- Direction of rotation is the top of the crankshaft towards the fluid head.

## M12 Performance Table

Pump Model	Plunger Diameter (in)	Displacement (GAL/REV)	Maximum Pressure (PSI)	Pump Capacity (GPM) @ Input Speed (RPM)						
				100 RPM	200 RPM	300RPM	350RPM	400RPM	450RPM	500RPM
M1207	0.875	0.0234	10,000	2.3	4.7	7.0	8.2	9.4	10.5	11.7
M1208	1.000	0.0306	7,600	3.1	6.1	9.2	10.7	12.2	13.8	15.3
M1210	1.250	0.0478	4,900	4.8	9.6	14.3	16.7	19.1	21.5	23.9
M1212	1.500	0.0688	3,400	6.9	13.8	20.6	24.1	27.5	31	34.4
M1214	1.750	0.0937	2,500	9.4	18.7	28.1	32.8	37.5	42.2	46.9
M1216	2.000	0.1224	1,900	12.2	24.5	36.7	42.8	49	55.1	61.2
M1218	2.250	0.1549	1,500	15.5	31	46.5	54.2	62	69.7	77.5
M1220	2.500	0.1912	1,250	19.1	38.2	57.4	66.9	76.5	86	95.6
M1222	2.750	0.2314	1,000	23.1	46.3	69.4	81	92.6	104	116
M1224	3.000	0.2754	850	27.5	55.1	82.6	96.4	110	124	138

### M12 NPSHr values for Disc Valves with 2-springs (5263970 and 5263971)

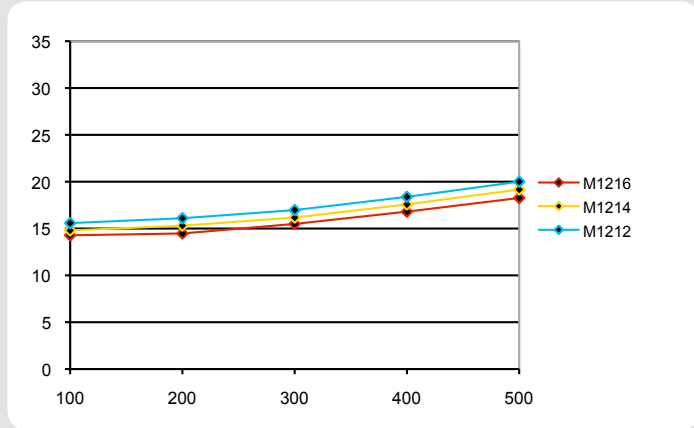

### M12 NPSHr values for Disc Valves with 2-springs (5267472 and 5267473)

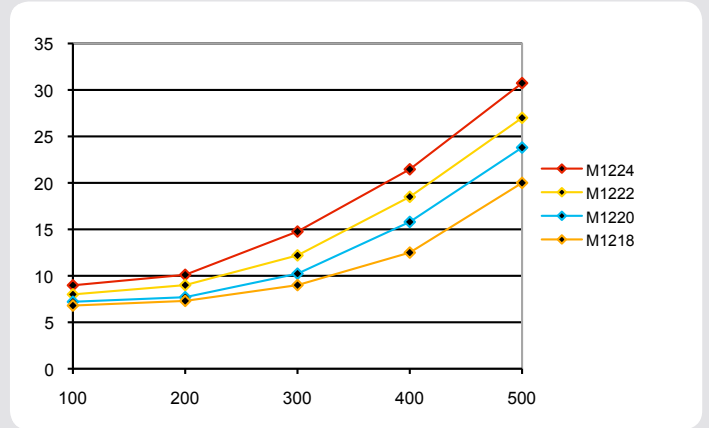

### M12 NPSHr values for Disc Valves with 1-spring (5263970)

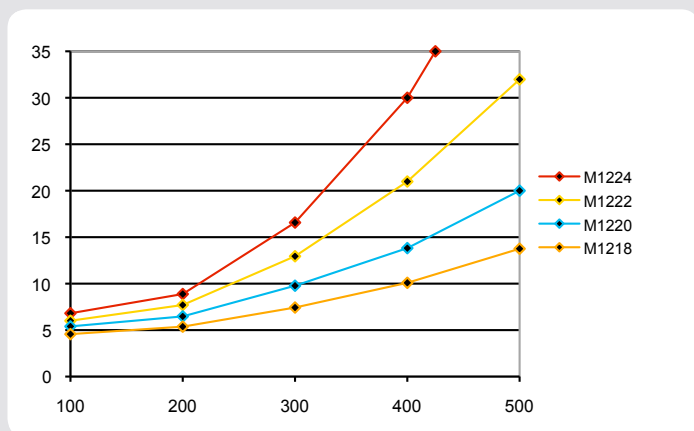

### M12 NPSHr values for AR Valves with 1-spring

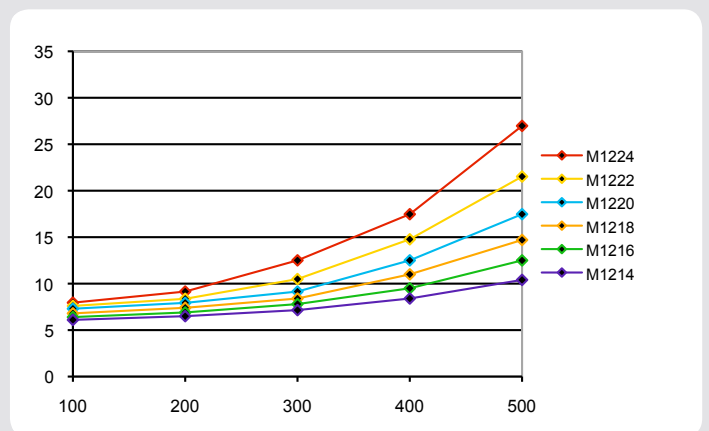

- Pump capacities shown are based on 100% volumetric efficiency.
- FMC recommends NPSHa (available) exceeds NPSHr (required) by 5 feet of water.
- Take special consideration when calculating NPSHa. Recalculate NPSHa after pump model has been selected for more accurate values.
- NPSHr values are in feet of water. If you are pumping a different liquid than water, convert the required NPSH from water to the liquid being pumped by dividing the published NPSHr value by the specific gravity of the liquid being pumped.
- FMC published NPSHr values are based on test data collected on specific pumps at the factory and are estimated values. Actual NPSHr values for an ordered pump can only be determined by a factor test. For NPSH critical applications, contact the factory for additional information and request an NPSHr test performed on your pump before shipment.

## M12 Plunger Pump Data

62 BHP Continuous Duty (77 BHP Intermittent Duty)

### Forged Pump Engineering Dimensional Outline

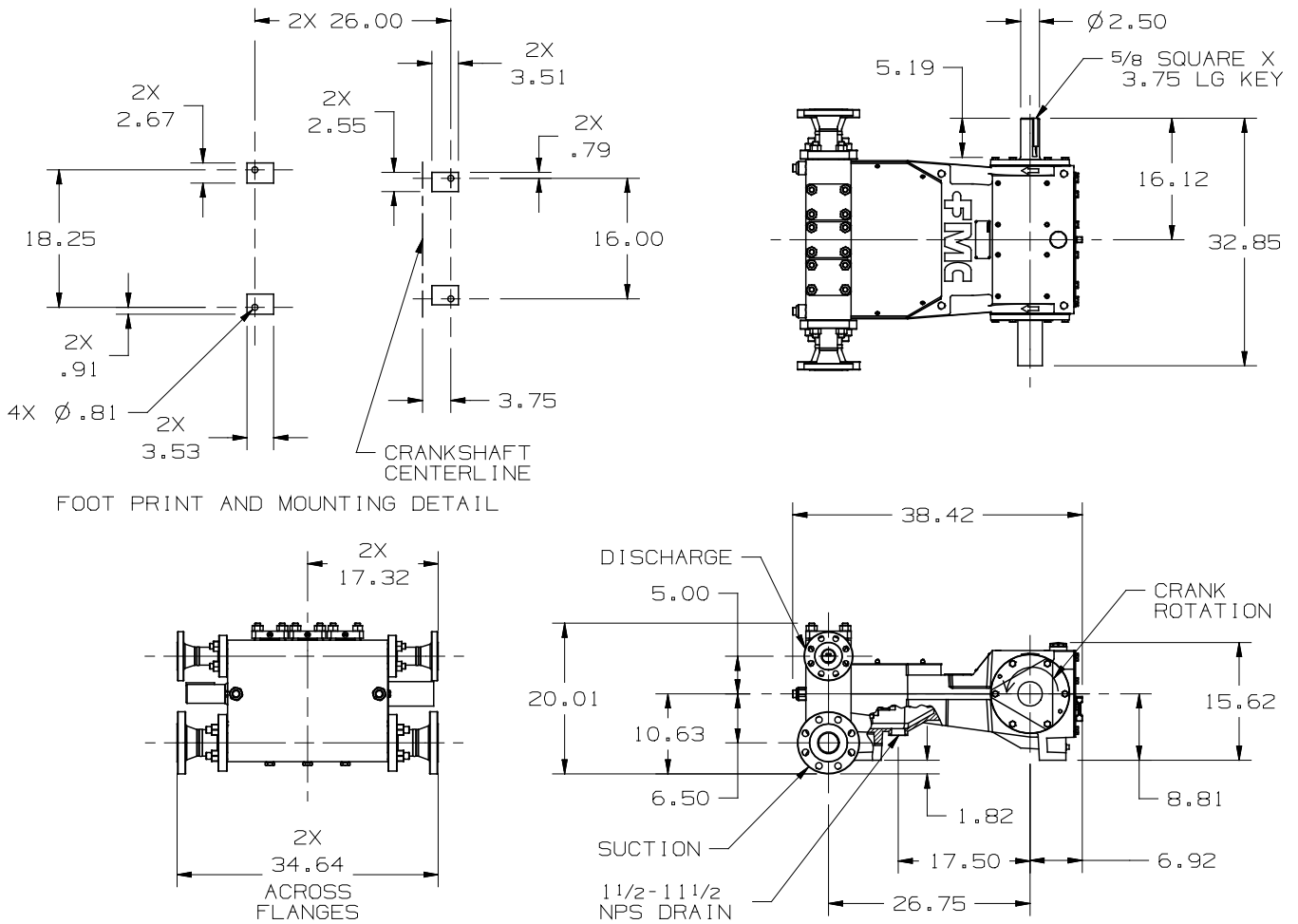

## M12 Plunger Pump Data

62 BHP Continuous Duty (77 BHP Intermittent Duty)

### Cast Pump Engineering Dimensional Outline

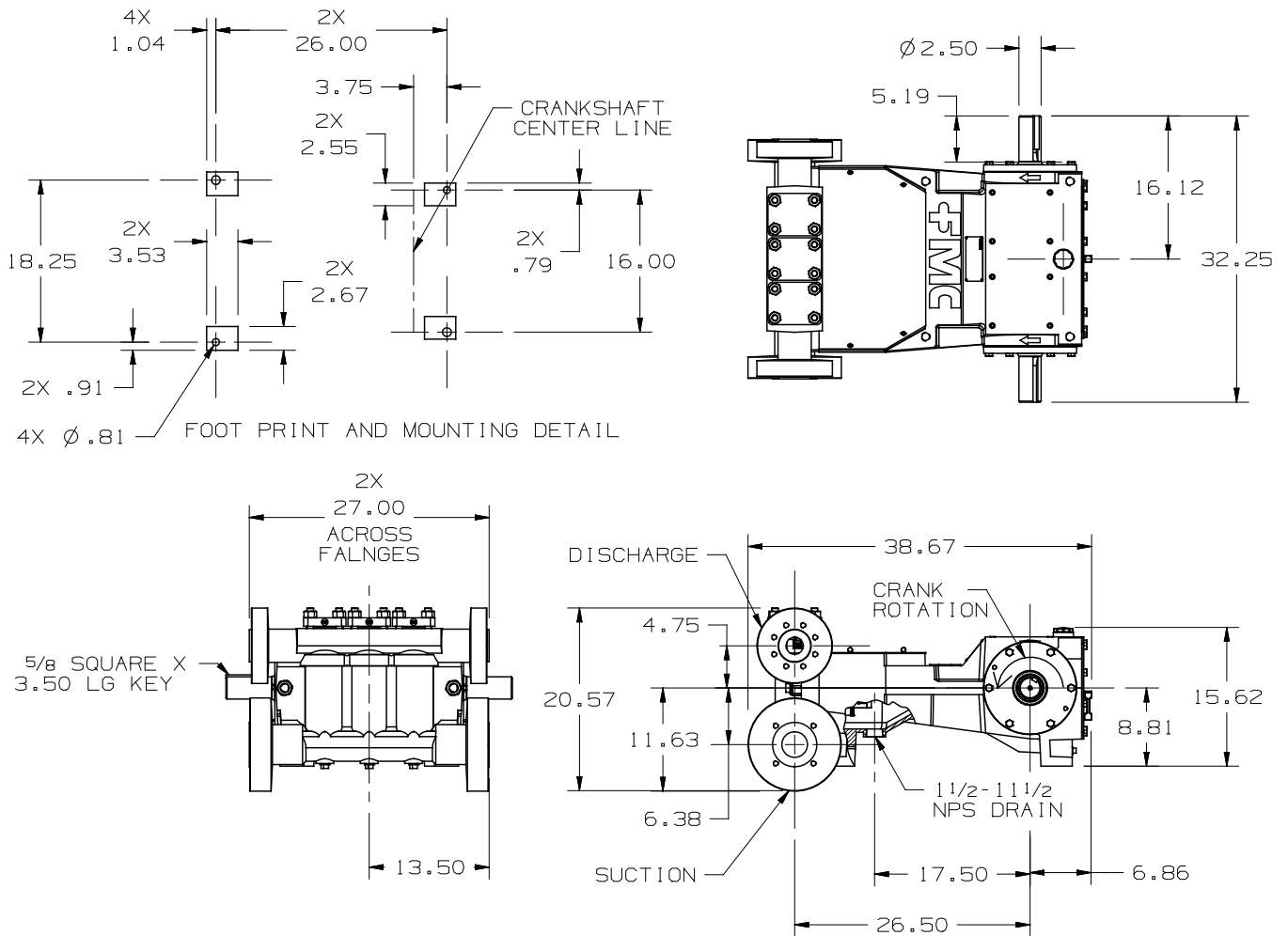

• Dimensions shown are for general sizing purposes and should not be used of construction. Contact FMC for actual dimensions of pump ordered.

• FMC reserves the right to modify this information without prior notice.

• Pump drawing dimensions in inches.

## M14 Plunger Pump Data

88 BHP Continuous Duty (104 BHP Intermittent Duty)

### Forged ISO Drawing

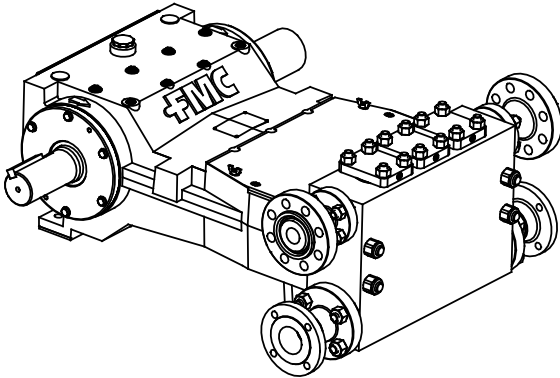

### Cast ISO Drawing

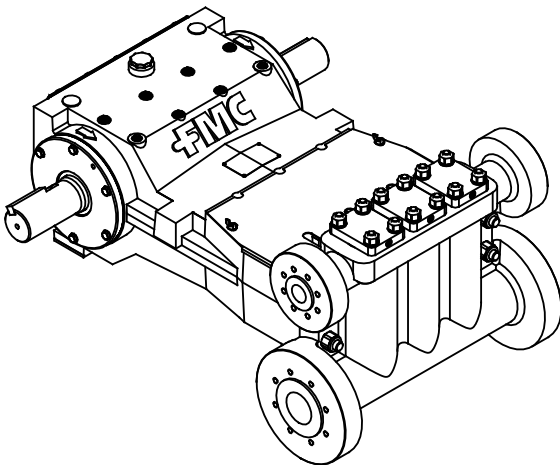

### Specifications

Pump Model	M14
Design Standard	API-674, Second Edition
Configuration	Horizontal Triplex Plunger
Number of Plungers	3
Stroke Length	3.5 Inches
Frame Load Rating	8,000 lbs
Forged Fluid Cylinder Pressure Rating	10,000 psi
Cast Fluid Cylinder Pressure Rating	3,000 psi
Pump Weight (Average)	1,800 lbs
Intermittent Duty Speed Rating	425 RPM
Continuous Duty Speed Rating	375 RPM
API-674 Max Recommended Speed	375 RPM
Minimum Speed *	100 RPM
Mechanical Efficiency	90%
Lubrication System (Standard)	Splash, Gravity Return
Lubrication System (Optional)	Pressurized, Motor Driven
Lube Oil Capacity	6.5 Gallons
Lube Oil Type	SAE 30
Maximum Fluid Temperature	200 °F (400 °F Capability)
Minimum Fluid Temperature	-20 °F (-50 °F Capability)
Valve Types	Disc Valves, Abrasion Resistant Valves

*\* Slower RPM can be achieved with the addition of a pressurized lubrication system*

Forged Fluid End Material	Cast Fluid End Material
A105 Carbon Steel	Ductile Iron
A350-LF2 Carbon Steel	Nickel Aluminum Bronze
316L Stainless Steel	316L Stainless Steel
2205 Duplex Stainless Steel	2205 Duplex Stainless Steel
Alloy Steel	

*\* Special Materials available on request*

Standard Connection Sizes	Suction	Discharge
M1408-M1420	3.0	2.0
M1418-M1432	4.0	2.0
M1428-M1432	4.0	3.0

*\* NPT Connections Available*

- Consult FMC for specific exceptions to API-674 and NACE standards.
- Consult FMC for any application where inlet pressures will exceed 10% of rated discharge pressure.
- Horsepower based on 90% mechanical efficiency. Actual application horsepower requirements can be calculated using the equation:  $BHP = (GPM * PSI) / (1714 * 0.90)$
- Direction of rotation is the top of the crankshaft towards the fluid head.

## M14 Performance Table

Pump Model	Plunger Diameter (in)	Displacement (GAL/REV)	Maximum Pressure (PSI)	Pump Capacity (GPM) @ Input Speed (RPM)						
				100 RPM	200 RPM	300RPM	350RPM	375RPM	400RPM	425RPM
M1408	1.000	0.0357	10,000	3.6	7.1	10.7	12.5	13.4	14.3	15.2
M1410	1.250	0.0558	6,500	5.6	11.2	16.7	19.5	20.9	22.3	23.7
M1412	1.500	0.0803	4,500	8.0	16.1	24.1	28.1	30.1	32.1	34.1
M1414	1.750	0.1093	3,300	10.9	21.9	32.8	38.3	41	43.7	46.5
M1416	2.000	0.1428	2,500	14.3	28.6	42.8	50.0	53.6	57.1	60.7
M1418	2.250	0.1807	2,000	18.1	36.1	54.2	63.2	67.8	72.3	76.8
M1420	2.500	0.2231	1,600	22.3	44.6	66.9	78.1	83.7	89.2	94.8
M1422	2.750	0.2700	1,350	27	54	81	95	101	108	115
M1424	3.000	0.3213	1,150	32.1	64.3	96.4	112	120	129	137
M1426	3.250	0.3771	1,000	37.7	75.4	113	132	141	151	160
M1428	3.500	0.4373	825	43.7	87.5	131	153	164	175	186
M1430	3.750	0.5020	725	50.2	100	151	176	188	201	213

## M14 NPSHr values for AR Valves with 1-spring

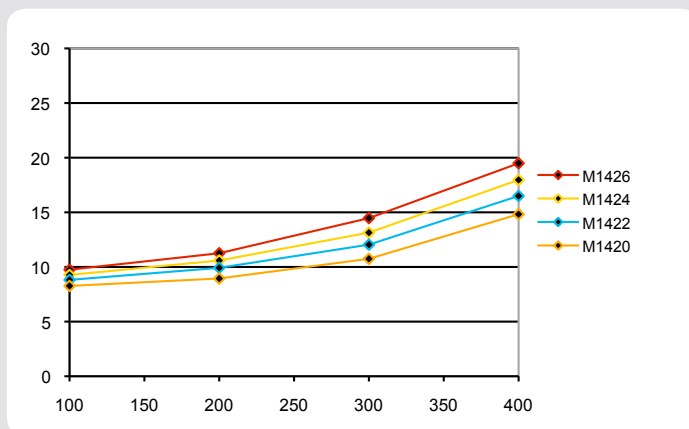

- Pump capacities shown are based on 100% volumetric efficiency.
- FMC recommends NPSHa (available) exceeds NPSHr (required) by 5 feet of water.
- Take special consideration when calculating NPSHa. Recalculate NPSHa after pump model has been selected for more accurate values.
- NPSHr values are in feet of water. If you are pumping a different liquid than water, convert the required NPSH from water to the liquid being pumped by dividing the published NPSHr value by the specific gravity of the liquid being pumped.
- FMC published NPSHr values are based on test data collected on specific pumps at the factory and are estimated values. Actual NPSHr values for an ordered pump can only be determined by a factor test. For NPSH critical applications, contact the factory for additional information and request an NPSHr test performed on your pump before shipment.

**M14 Plunger Pump Data**

88 BHP Continuous Duty (104 BHP Intermittent Duty)

**Forged Pump Engineering Dimensional Outline**

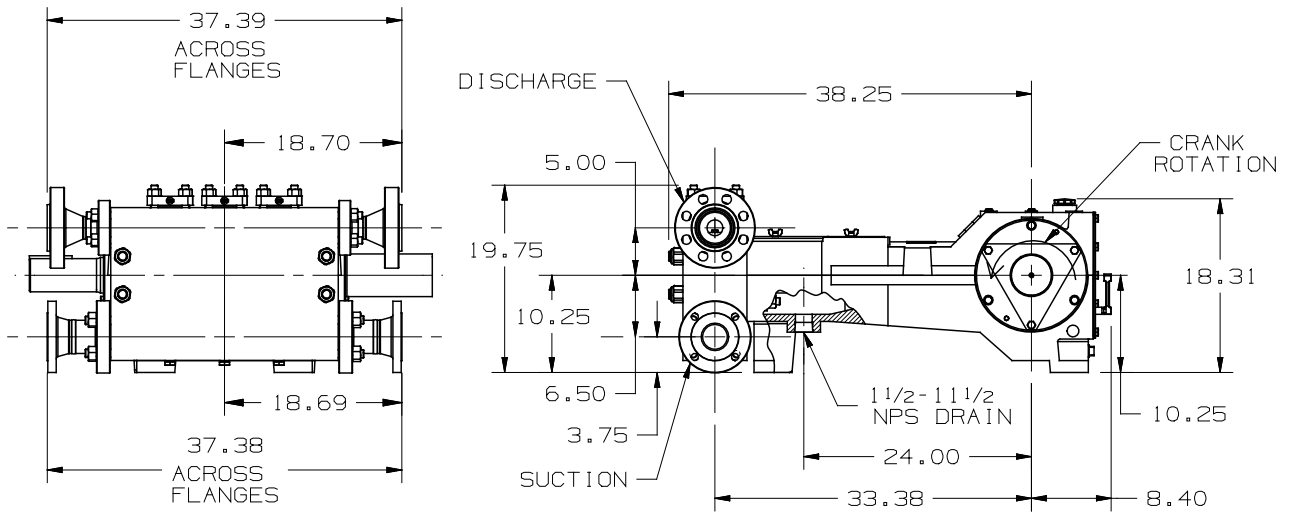
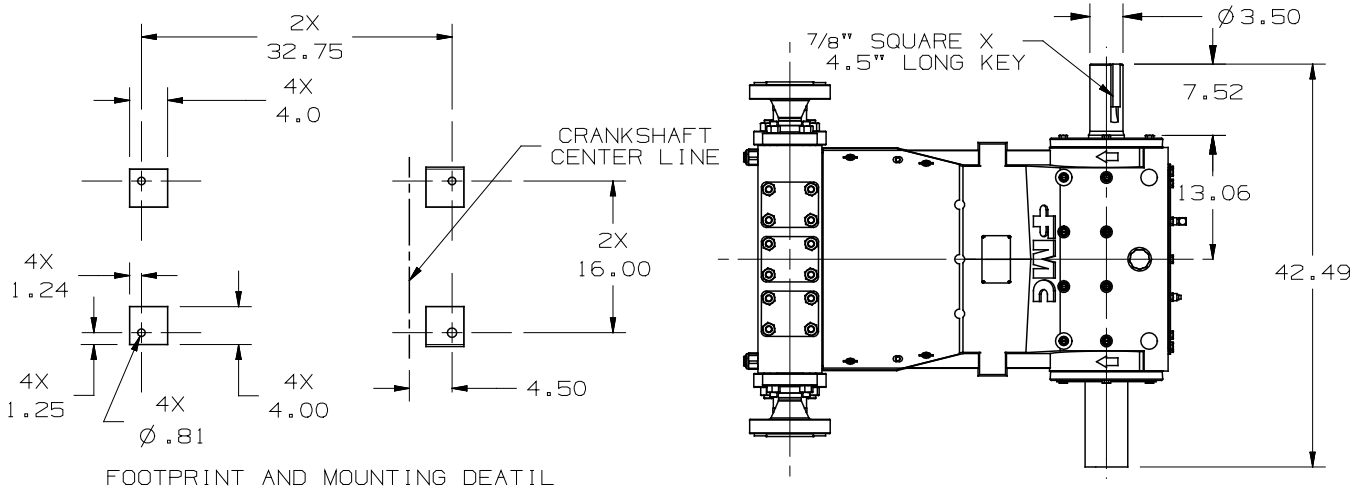

## M14 Plunger Pump Data

88 BHP Continuous Duty (104 BHP Intermittent Duty)

### Cast Pump Engineering Dimensional Outline

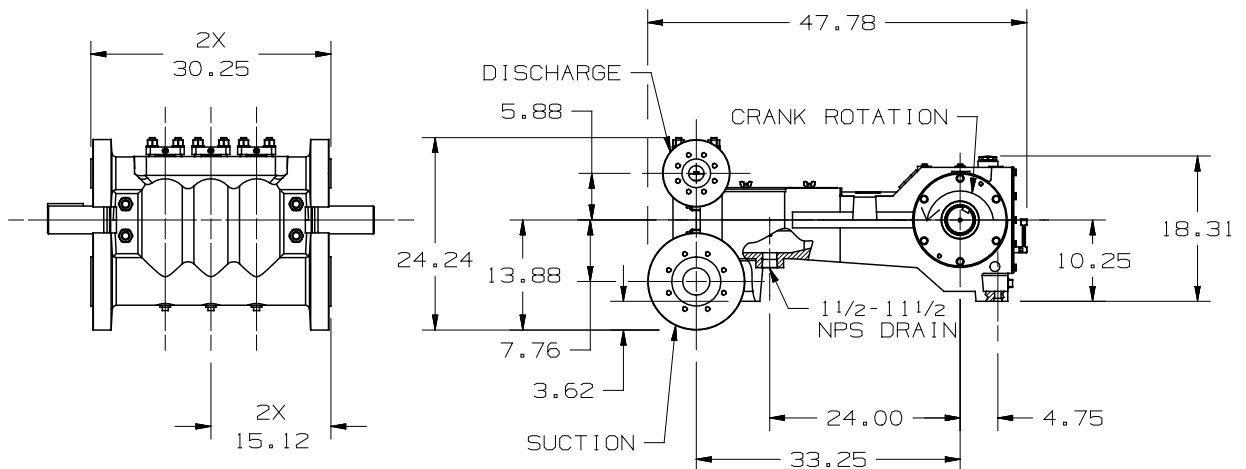
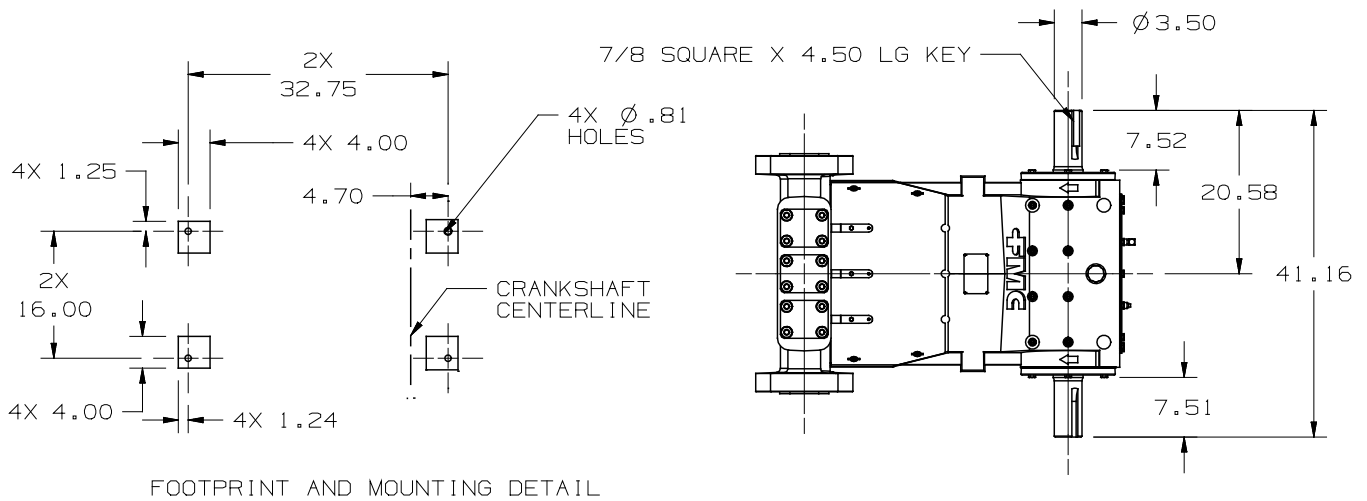

• Dimensions shown are for general sizing purposes and should not be used of construction. Contact FMC for actual dimensions of pump ordered.

• FMC reserves the right to modify this information without prior notice.

• Pump drawing dimensions in inches.

## M16 Plunger Pump Data

117 BHP Continuous Duty (142 BHP Intermittent Duty)

### Forged ISO Drawing

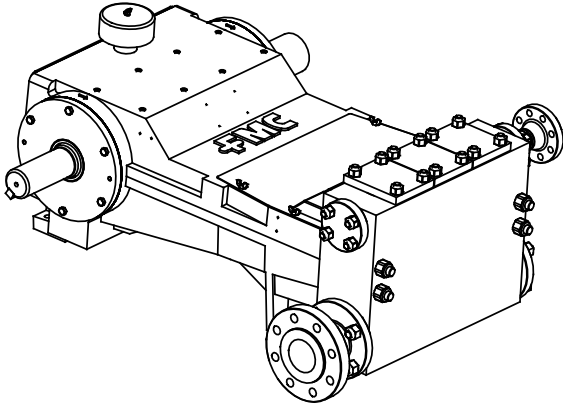

### Cast ISO Drawing

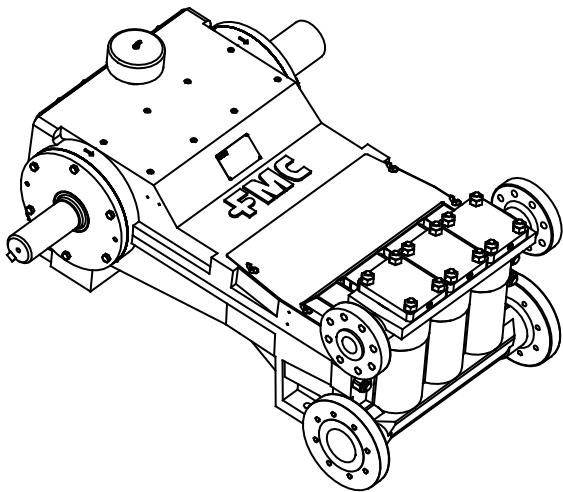

### Specifications

Pump Model	M16
Design Standard	API-674, Second Edition
Configuration	Horizontal Triplex Plunger
Number of Plungers	3
Stroke Length	4.0 Inches
Frame Load Rating	9,800 lbs
Forged Fluid Cylinder Pressure Rating	10,000 psi
Cast Fluid Cylinder Pressure Rating	3,000 psi
Pump Weight (Average)	2,400 lbs
Intermittent Duty Speed Rating	425 RPM
Continuous Duty Speed Rating	350 RPM
API-674 Max Recommended Speed	350 RPM
Minimum Speed *	100 RPM
Mechanical Efficiency	90%
Lubrication System (Standard)	Splash, Gravity Return
Lubrication System (Optional)	Pressurized, Motor or Crank Driven
Lube Oil Capacity	10 Gallons
Lube Oil Type	SAE 30
Maximum Fluid Temperature	200 °F (400 °F Capability)
Minimum Fluid Temperature	-20 °F (-50 °F Capability)
Valve Types	Disc Valves, Abrasion Resistant Valves

\* Slower RPM can be achieved with the addition of a pressurized lubrication system

Forged Fluid End Material	Cast Fluid End Material
A105 Carbon Steel	Ductile Iron
A350-LF2 Carbon Steel	Nickel Aluminum Bronze
316L Stainless Steel	316L Stainless Steel
2205 Duplex Stainless Steel	2205 Duplex Stainless Steel
Alloy Steel	

\* Special Materials available on request

Standard Connection Sizes	Suction	Discharge
M1609-M1618	3.0	1.5
M1618-M1636	4.0	2.0
M1628-M1636	6.0	3.0

\* NPT Connections Available

- Consult FMC for specific exceptions to API-674 and NACE standards.
- Consult FMC for any application where inlet pressures will exceed 10% of rated discharge pressure.
- Horsepower based on 90% mechanical efficiency. Actual application horsepower requirements can be calculated using the equation:  $BHP = (GPM * PSI) / (1714 * 0.90)$
- Direction of rotation is the top of the crankshaft towards the fluid head.

## M16 Performance Table

Pump Model	Plunger Diameter (in)	Displacement (GAL/REV)	Maximum Pressure (PSI)	Pump Capacity (GPM) @ Input Speed (RPM)					
				100 RPM	200 RPM	300RPM	350RPM	400RPM	425RPM
M1609	1.125	0.0516	10,000	5.2	10.3	15.5	18.1	20.6	21.9
M1610	1.250	0.0637	8,000	6.4	12.7	19.1	22.3	25.5	27.1
M1612	1.500	0.0918	5,500	9.2	18.4	27.5	32.1	36.7	39.0
M1614	1.750	0.1249	4,065	12.5	25.0	37.5	43.7	50.0	53.1
M1616	2.000	0.1632	3,115	16.3	32.6	49.0	57.1	65.3	69.4
M1618	2.250	0.2065	2,460	20.7	41.3	62.0	72.3	82.6	87.8
M1620	2.500	0.2550	1,990	25.5	51.0	76.5	89.3	102	108
M1622	2.750	0.3085	1,650	30.9	61.7	92.6	108	123	131
M1624	3.000	0.3672	1,385	36.7	73.4	110	128	147	156
M1626	3.250	0.4309	1,180	43.1	86.2	129	151	172	183
M1628	3.500	0.4998	1,015	50.0	100	150	175	200	212
M1630	3.750	0.5737	885	57.4	115	172	201	229	244
M1632	4.000	0.6528	775	65.3	131	196	228	261	277
M1634	4.250	0.7369	650	73.7	147	221	258	295	313
M1636	4.500	0.8262	570	82.6	165	248	289	330	351

### M16 NPSHr values for Disc Valves with 2-springs

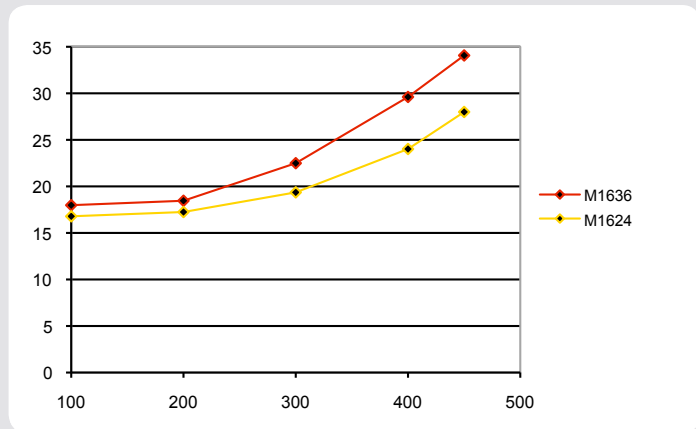

### M16 NPSHr values for Disc Valves with 1-spring

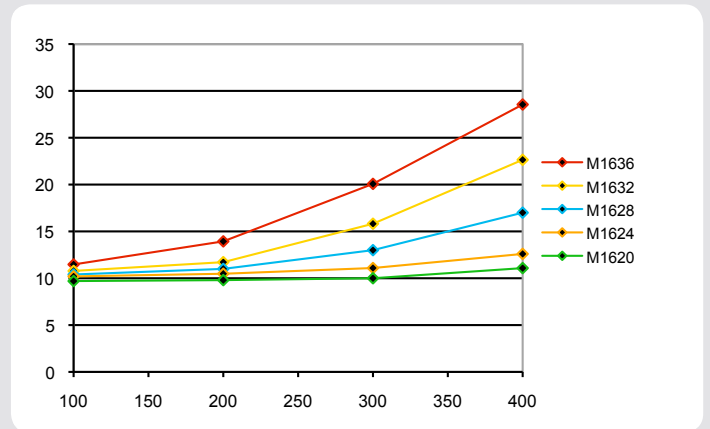

### M16 NPSHr values for AR Valves with 1-spring

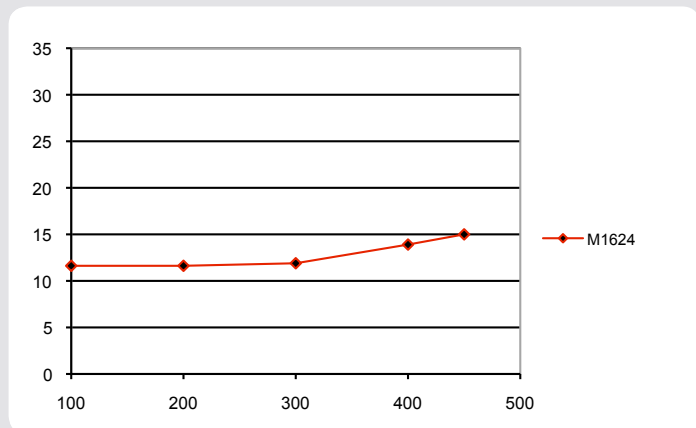

- Pump capacities shown are based on 100% volumetric efficiency.
- FMC recommends NPSHa (available) exceeds NPSHr (required) by 5 feet of water.
- Take special consideration when calculating NPSHa. Recalculate NPSHa after pump model has been selected for more accurate values.
- NPSHr values are in feet of water. If you are pumping a different liquid than water, convert the required NPSH from water to the liquid being pumped by dividing the published NPSHr value by the specific gravity of the liquid being pumped.
- FMC published NPSHr values are based on test data collected on specific pumps at the factory and are estimated values. Actual NPSHr values for an ordered pump can only be determined by a factor test. For NPSH critical applications, contact the factory for additional information and request an NPSHr test performed on your pump before shipment.

## M16 Plunger Pump Data

117 BHP Continuous Duty (142 BHP Intermittent Duty)

### Forged Pump Engineering Dimensional Outline

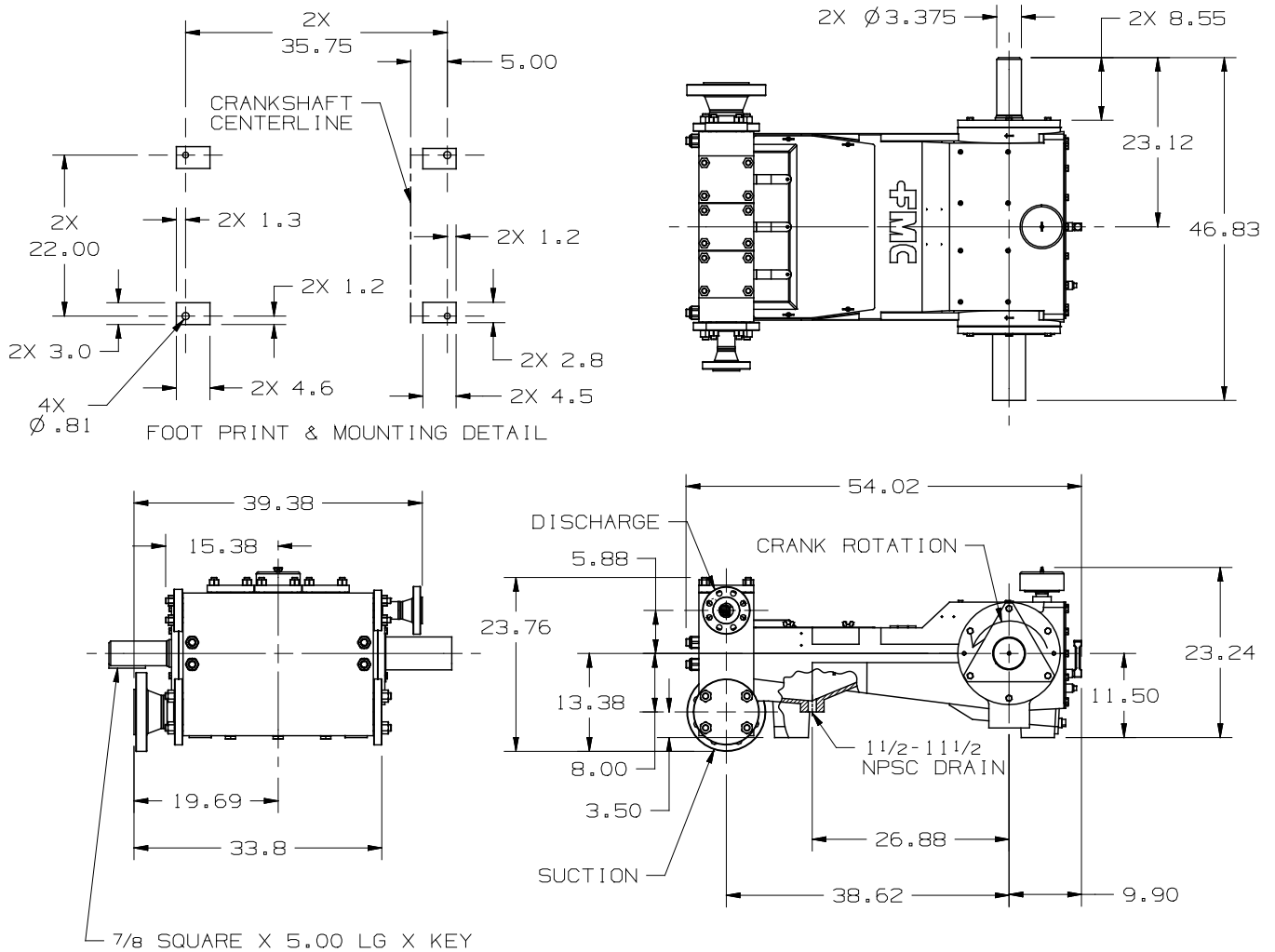

## M16 Plunger Pump Data

117 BHP Continuous Duty (142 BHP Intermittent Duty)

### Cast Pump Engineering Dimensional Outline

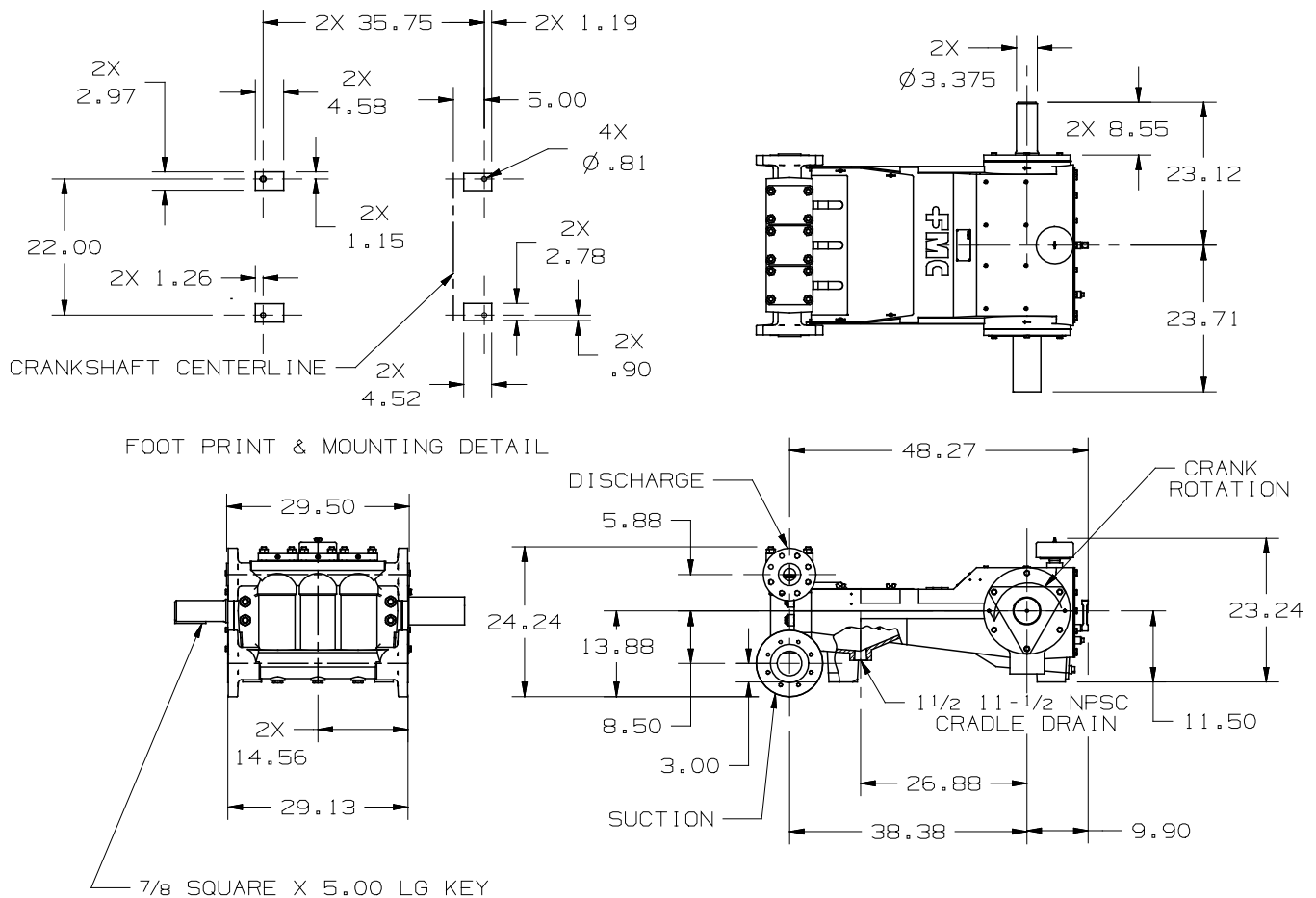

• Dimensions shown are for general sizing purposes and should not be used of construction. Contact FMC for actual dimensions of pump ordered.

• FMC reserves the right to modify this information without prior notice.

• Pump drawing dimensions in inches.

## M18 Plunger Pump Data

150 BHP Continuous Duty (190 BHP Intermittent Duty)

### Forged ISO Drawing

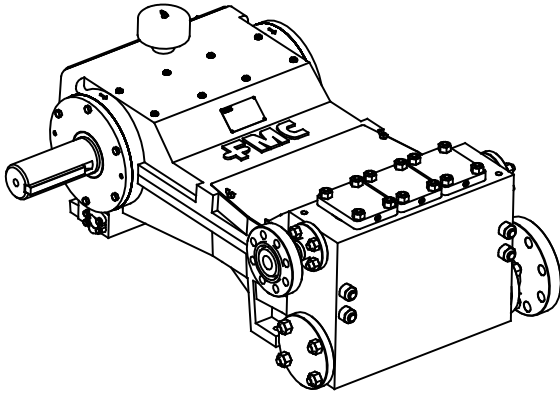

### Cast ISO Drawing

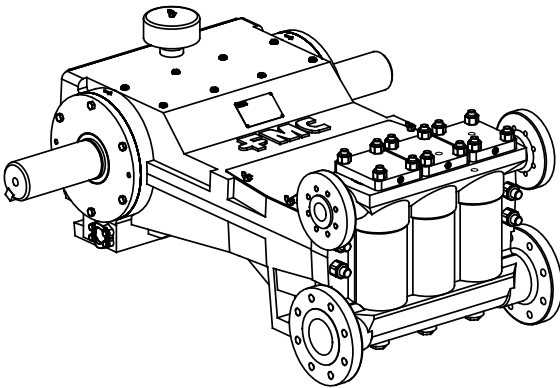

### Specifications

Pump Model	M18
Design Standard	API-674, Second Edition
Configuration	Horizontal Triplex Plunger
Number of Plungers	3
Stroke Length	4.5 Inches
Frame Load Rating	12,000 lbs
Forged Fluid Cylinder Pressure Rating	10,000 psi
Cast Fluid Cylinder Pressure Rating	3,000 psi
Pump Weight (Average)	2,400 lbs
Intermittent Duty Speed Rating	400 RPM
Continuous Duty Speed Rating	330 RPM
API-674 Max Recommended Speed	330 RPM
Minimum Speed	100 RPM
Mechanical Efficiency *	90%
Lubrication System (Standard)	Splash, Gravity Return
Lubrication System (Optional)	Pressurized, Motor or Crank Driven
Lube Oil Capacity	10 Gallons
Lube Oil Type	SAE 30
Maximum Fluid Temperature	200 °F (400 °F Capability)
Minimum Fluid Temperature	-20 °F (-50 °F Capability)
Valve Types	Disc Valves, Abrasion Resistant Valves

*\* Slower RPM can be achieved with the addition of a pressurized lubrication system*

Forged Fluid End Material	Cast Fluid End Material
A105 Carbon Steel	Ductile Iron
A350-LF2 Carbon Steel	Nickel Aluminum Bronze
316L Stainless Steel	316L Stainless Steel
2205 Duplex Stainless Steel	2205 Duplex Stainless Steel
Alloy Steel	

*\* Special Materials available on request*

Standard Connection Sizes	Suction	Discharge
M1810-M1816	3.0	1.5
M1818-M1826	4.0	2.0
M1828-M1836	6.0	3.0

*\* NPT Connections Available*

- Consult FMC for specific exceptions to API-674 and NACE standards.
- Consult FMC for any application where inlet pressures will exceed 10% of rated discharge pressure.
- Horsepower based on 90% mechanical efficiency. Actual application horsepower requirements can be calculated using the equation:  $BHP = (GPM * PSI) / (1714 * 0.90)$
- Direction of rotation is the top of the crankshaft towards the fluid head.

## M18 Performance Table

Pump Model	Plunger Diameter (in)	Displacement (GAL/REV)	Maximum Pressure (PSI)	Pump Capacity (GPM) @ Input Speed (RPM)					
				100 RPM	200 RPM	300RPM	330RPM	350RPM	400RPM
M1810	1.250	0.0717	9,800	7.2	14	22	24	25	29
M1812	1.500	0.1033	6,800	10	21	31	34	36	41
M1814	1.750	0.1406	5,000	14	28	42	46	49	56
M1816	2.000	0.1836	3,800	18	37	55	61	64	73
M1818	2.250	0.2324	3,000	23	47	70	77	81	93
M1820	2.500	0.2869	2,400	29	57	86	95	100	115
M1822	2.750	0.3471	2,000	35	69	104	115	122	139
M1824	3.000	0.4131	1,700	41	83	124	136	145	165
M1826	3.250	0.4848	1,400	49	97	145	160	170	194
M1828	3.500	0.5623	1,200	56	113	169	186	197	225
M1830	3.750	0.6455	1,100	65	129	194	213	226	258
M1832	4.000	0.7344	1,000	73	147	220	242	257	294
M1834	4.250	0.8291	800	83	166	249	274	290	332
M1836	4.500	0.9295	750	93	186	279	307	325	372

### M18 NPSHr values for Disc Valves with 2-springs

### M18 NPSHr values for AR Valves with 1-spring

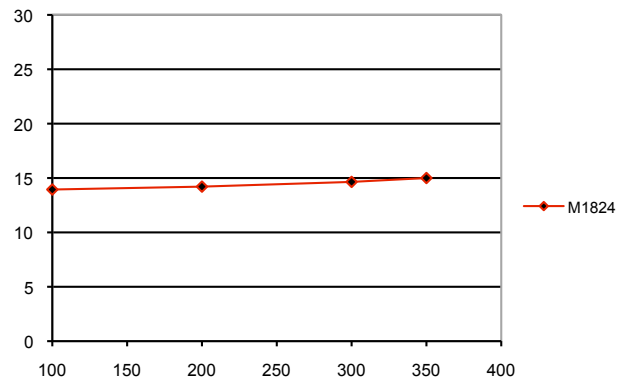
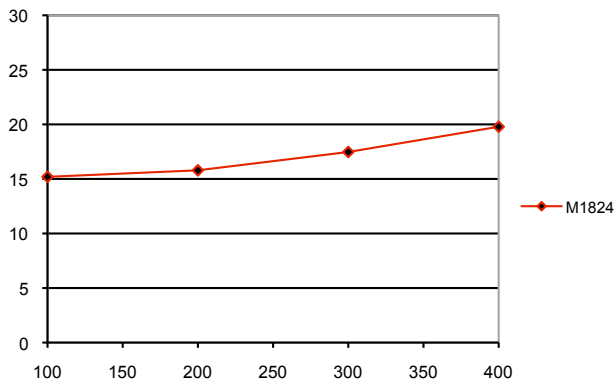

- Pump capacities shown are based on 100% volumetric efficiency.
- FMC recommends NPSHa (available) exceeds NPSHr (required) by 5 feet of water.
- Take special consideration when calculating NPSHa. Recalculate NPSHa after pump model has been selected for more accurate values.
- NPSHr values are in feet of water. If you are pumping a different liquid than water, convert the required NPSH from water to the liquid being pumped by dividing the published NPSHr value by the specific gravity of the liquid being pumped.
- FMC published NPSHr values are based on test data collected on specific pumps at the factory and are estimated values. Actual NPSHr values for an ordered pump can only be determined by a factor test. For NPSH critical applications, contact the factory for additional information and request an NPSHr test performed on your pump before shipment.

## M18 Plunger Pump Data

150 BHP Continuous Duty (190 BHP Intermittent Duty)

### Forged Pump Engineering Dimensional Outline

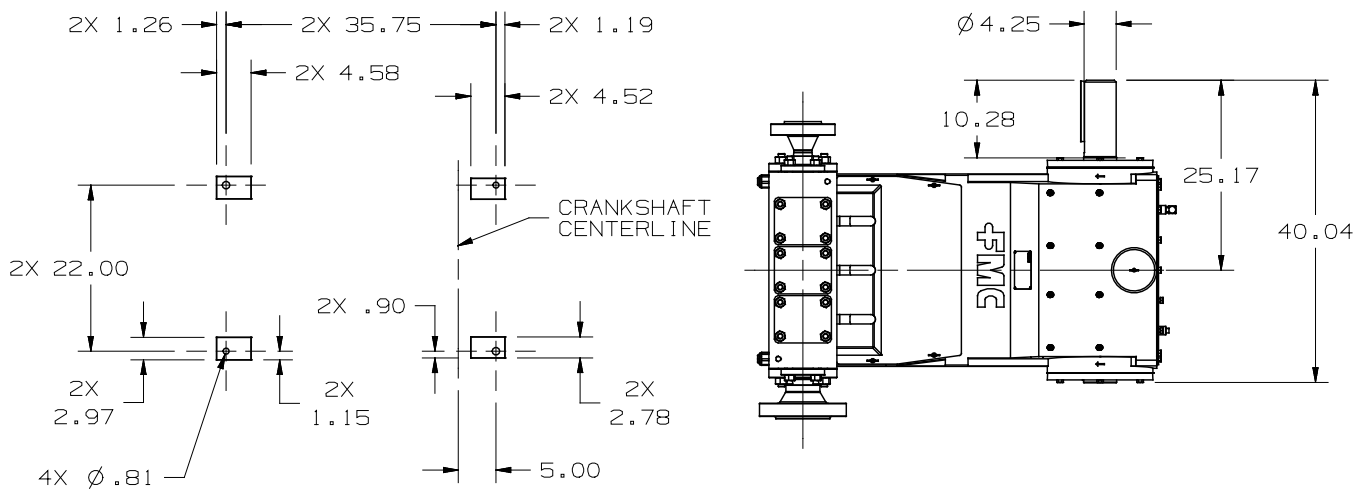

FOOT PRINT AND MOUNTING DETAIL

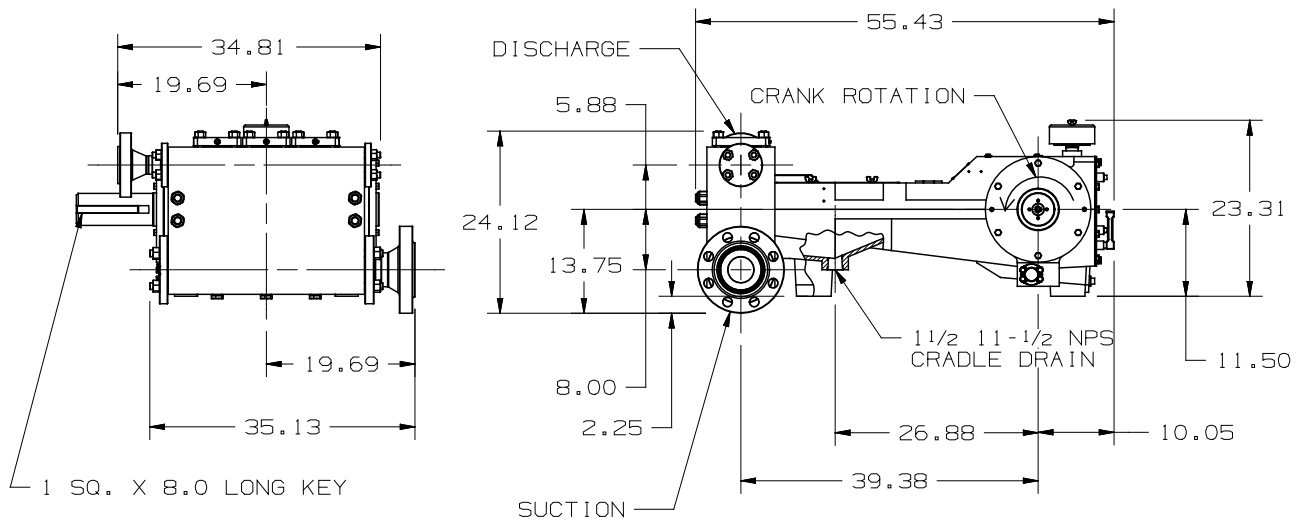

## M18 Plunger Pump Data

150 BHP Continuous Duty (190 BHP Intermittent Duty)

### Cast Pump Engineering Dimensional Outline

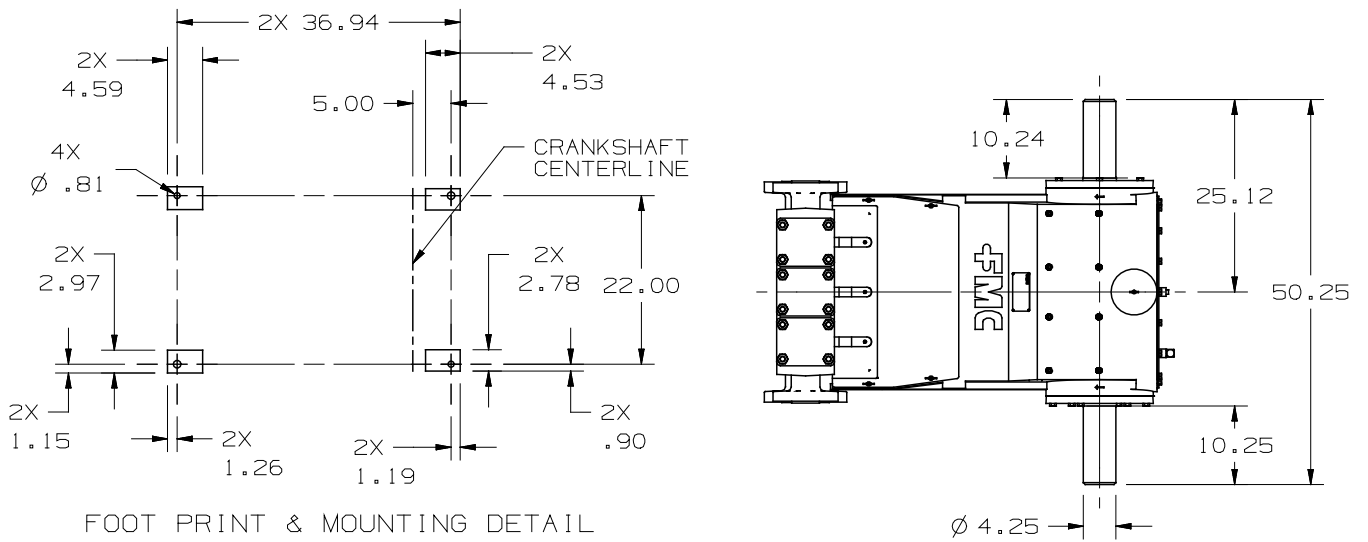

FOOT PRINT & MOUNTING DETAIL

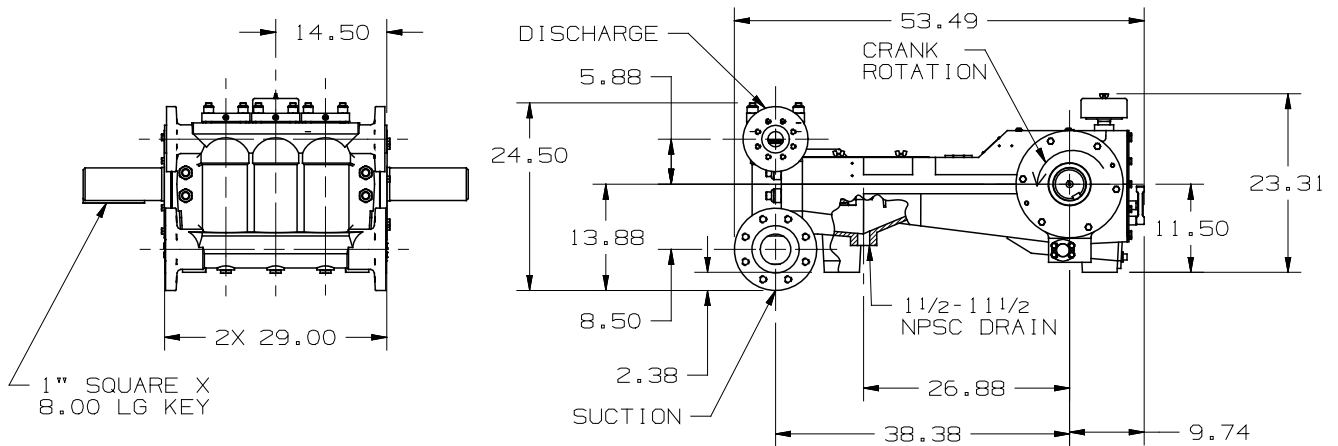

• Dimensions shown are for general sizing purposes and should not be used of construction. Contact FMC for actual dimensions of pump ordered.

• FMC reserves the right to modify this information without prior notice.

• Pump drawing dimensions in inches.

## M28 Plunger Pump Data

350 BHP Continuous Duty (440 BHP Intermittent Duty)

### Forged ISO Drawing

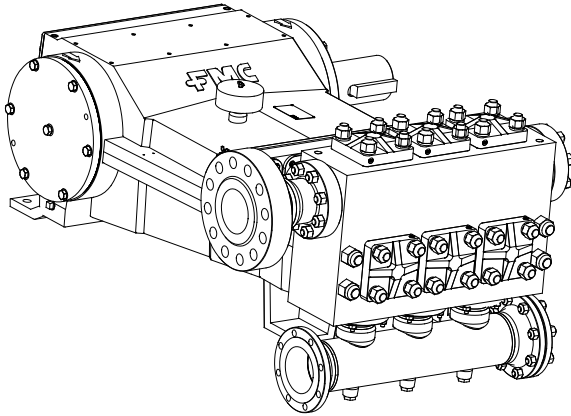

### Specifications

Pump Model	M28
Design Standard	API-674, Second Edition
Configuration	Horizontal Triplex Plunger
Number of Plungers	3
Stroke Length	7.0 Inches
Frame Load Rating	25,000 lbs
Forged Fluid Cylinder Pressure Rating	10,000 psi
Cast Fluid Cylinder Pressure Rating	Not Available
Pump Weight (Average)	5,500 lbs
Intermittent Duty Speed Rating	300 RPM
Continuous Duty Speed Rating	240 RPM
API-674 Max Recommended Speed	240 RPM
Minimum Speed *	100 RPM
Mechanical Efficiency	90%
Lubrication System (Standard)	Splash, Gravity Return
Lubrication System (Optional)	Pressurized, Motor or Crank Driven
Lube Oil Capacity	13.75 Gallons
Lube Oil Type	SAE 30
Maximum Fluid Temperature	200 °F (400 °F Capability)
Minimum Fluid Temperature	-20 °F (-50 °F Capability)
Valve Types	Disc Valves, Abrasion Resistant Valves

\* Slower RPM can be achieved with the addition of a pressurized lubrication system

Forged Fluid End Material	
A105 Carbon Steel	
A350-LF2 Carbon Steel	
316L Stainless Steel	
2205 Duplex Stainless Steel	
Alloy Steel	

\* Special Materials available on request

Standard Connection Sizes	Suction	Discharge
M2812-M2820	4.0	2.0
M2822-M2832	6.0	3.0
M2834-M2842	8.0	4.0
M2844-M2850	10.0	4.0

\* NPT Connections Available

- Consult FMC for specific exceptions to API-674 and NACE standards.
- Consult FMC for any application where inlet pressures will exceed 10% of rated discharge pressure.
- Horsepower based on 90% mechanical efficiency. Actual application horsepower requirements can be calculated using the equation:  $BHP = (GPM * PSI) / (1714 * 0.90)$
- Direction of rotation is the top of the crankshaft towards the fluid head.

## M28 Performance Table

Pump Model	Plunger Diameter (in)	Displacement (GAL/REV)	Pressure (PSI)	Pump Capacity (GPM) @ Input Speed (RPM)					
				100 RPM	150RPM	200RPM	240RPM	250RPM	300RPM
M2812	1.500	0.1606	10,000	16	24	32	39	40	48
M2814	1.750	0.2187	10,000	22	33	44	53	55	66
M2816	2.000	0.2856	7,960	29	43	57	69	71	86
M2818	2.250	0.3615	6,300	36	54	72	87	90	109
M2820	2.500	0.4462	5,100	45	67	89	107	112	134
M2822	2.750	0.5400	4,200	54	81	108	130	135	162
M2824	3.000	0.6426	3,540	64	96	129	154	161	193
M2826	3.250	0.7542	3,015	75	113	151	181	189	226
M2828	3.500	0.8746	2,600	88	131	175	210	219	262
M2830	3.750	1.0041	2,260	100	151	201	241	251	301
M2832	4.000	1.1424	1,990	114	171	229	274	286	343
M2834	4.250	1.2897	1,760	129	194	258	310	322	387
M2836	4.500	1.4458	1,570	145	217	289	347	361	434
M2838	4.750	1.6110	1,400	161	242	322	387	403	483
M2840	5.000	1.7580	1,275	176	264	352	422	440	527
M2842	5.250	1.9680	1,155	197	295	394	472	492	590
M2844	5.500	2.1598	1,050	216	324	432	518	540	648
M2846	5.750	2.3607	960	236	354	472	567	590	708
M2848	6.000	2.5704	880	257	386	514	617	643	771
M2850	6.250	2.7891	815	279	418	558	669	697	837

## M28 NPSHr values for Disc Valves with 2-springs

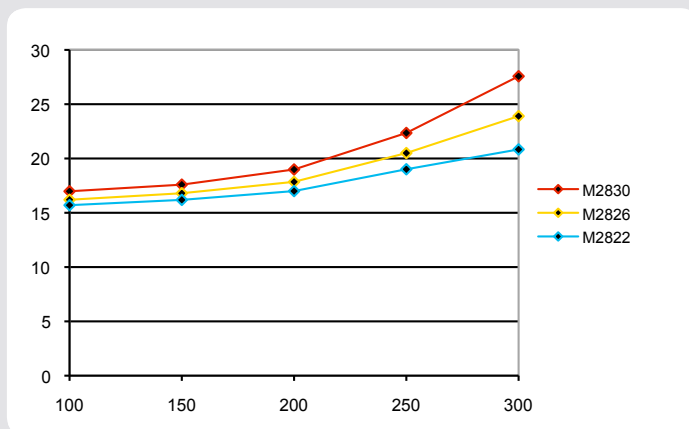

FMC Bolt-on Gearbox Ratios Available
6.17 : 1
7.44 : 1
9.58 : 1

- Pump capacities shown are based on 100% volumetric efficiency.
- FMC recommends NPSHa (available) exceeds NPSHr (required) by 5 feet of water.
- Take special consideration when calculating NPSHa. Recalculate NPSHa after pump model has been selected for more accurate values.
- NPSHr values are in feet of water. If you are pumping a different liquid than water, convert the required NPSH from water to the liquid being pumped by dividing the published NPSHr value by the specific gravity of the liquid being pumped.
- FMC published NPSHr values are based on test data collected on specific pumps at the factory and are estimated values. Actual NPSHr values for an ordered pump can only be determined by a factor test. For NPSH critical applications, contact the factory for additional information and request an NPSHr test performed on your pump before shipment.

## M28 Plunger Pump Data

350 BHP Continuous Duty (440 BHP Intermittent Duty)

### Forged Pump Engineering Dimensional Outline

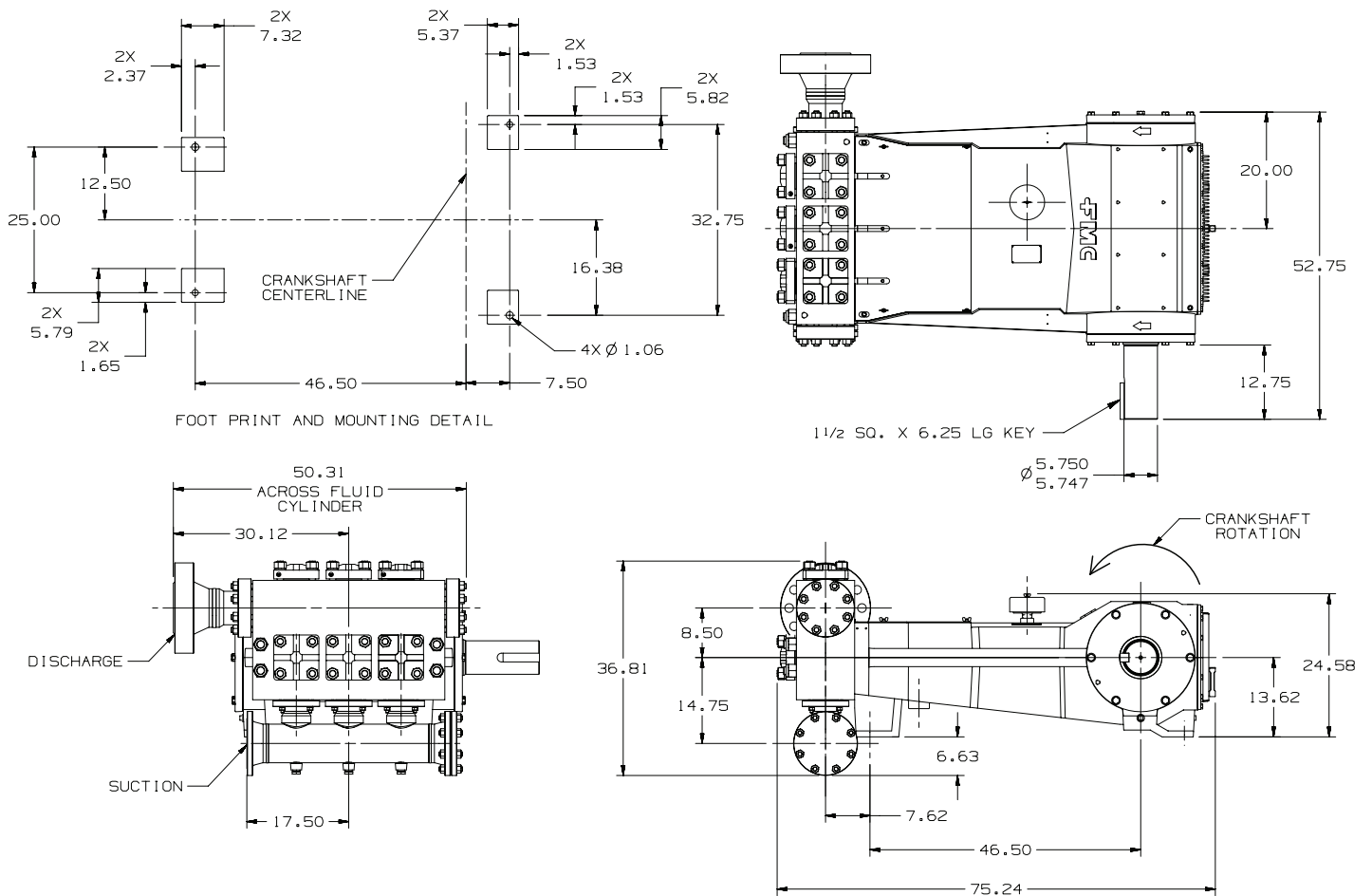

## M28 Plunger Pump Data

350 BHP Continuous Duty (440 BHP Intermittent Duty)

## M28 Cast Pump with Gearbox Engineering Dimensional Outline

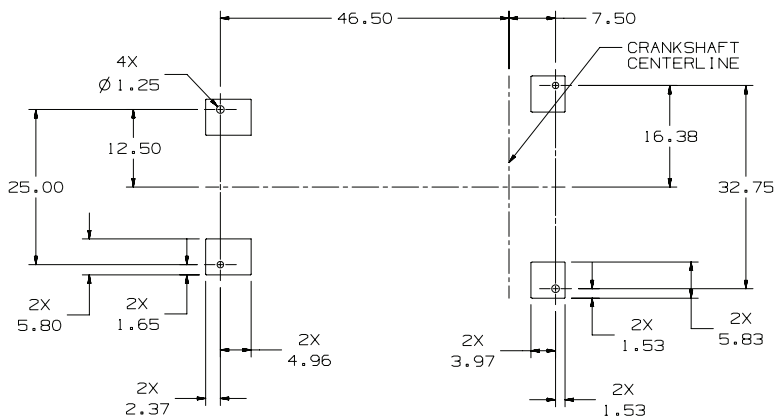

FOOT PRINT & MOUNTING DETAIL

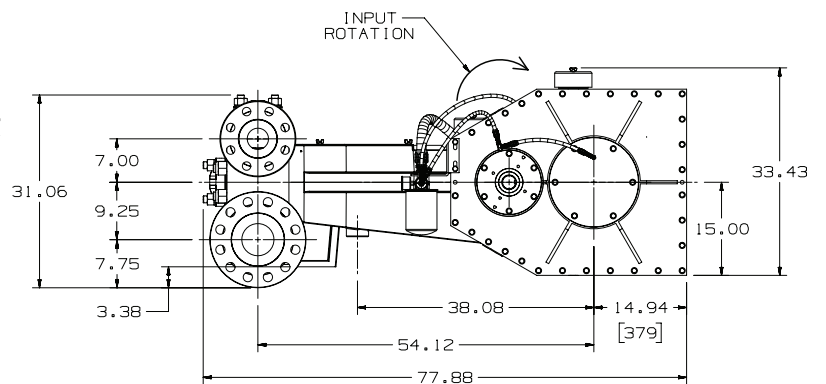
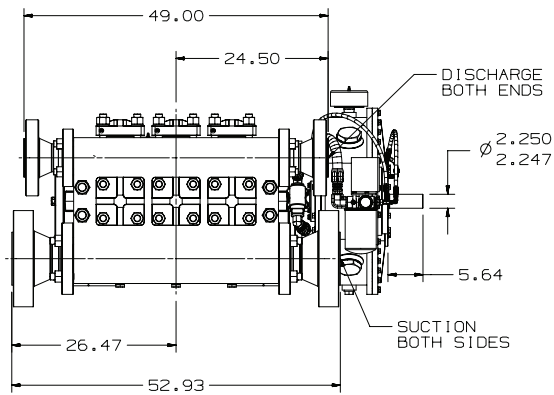
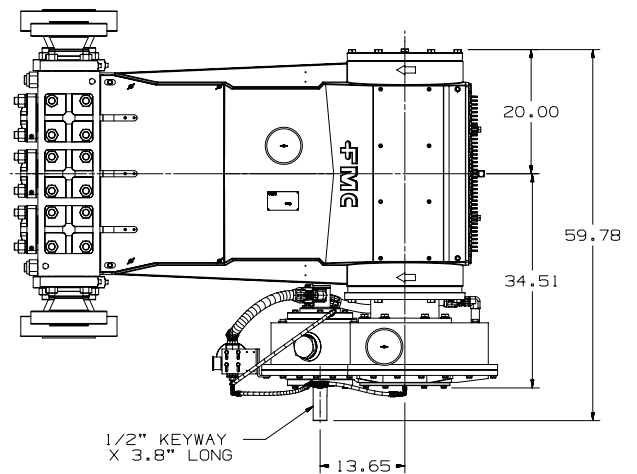

• Dimensions shown are for general sizing purposes and should not be used of construction. Contact FMC for actual dimensions of pump ordered.

• FMC reserves the right to modify this information without prior notice.

• Pump drawing dimensions in inches.

## Q16 Plunger Pump Data

198 BHP Continuous Duty (240 BHP Intermittent Duty)

### Forged ISO Drawing

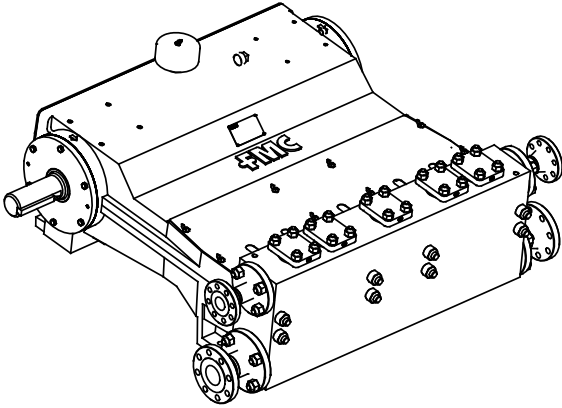

### Cast ISO Drawing

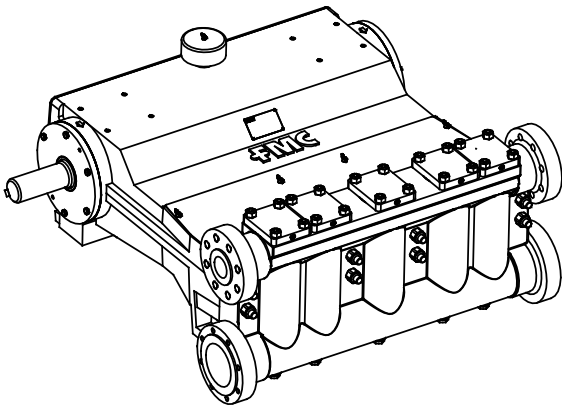

### Specifications

Pump Model	Q16
Design Standard	API-674, Second Edition
Configuration	Horizontal Quintuplex Plunger
Number of Plungers	5
Stroke Length	4.0 Inches
Frame Load Rating	10,000 lbs
Forged Fluid Cylinder Pressure Rating	10,000 psi
Cast Fluid Cylinder Pressure Rating	3,000 psi
Pump Weight (Average)	4,500 lbs
Intermittent Duty Speed Rating	425 RPM
Continuous Duty Speed Rating	350 RPM
API-674 Max Recommended Speed	350 RPM
Minimum Speed *	100 RPM
Mechanical Efficiency	90%
Lubrication System (Standard)	Splash, Gravity Return
Lubrication System (Optional)	Pressurized, Motor or CrankDriven
Lube Oil Capacity	16 Gallons
Lube Oil Type	SAE 30
Maximum Fluid Temperature	200 °F (400 °F Capability)
Minimum Fluid Temperature	-20 °F (-50 °F Capability)
Valve Types	Disc Valves, Abrasion Resistant Valves

*\* Slower RPM can be achieved with the addition of a pressurized lubrication system*

Forged Fluid End Material	Cast Fluid End Material
A105 Carbon Steel	Ductile Iron
A350-LF2 Carbon Steel	Nickel Aluminum Bronze
316L Stainless Steel	316L Stainless Steel
2205 Duplex Stainless Steel	2205 Duplex Stainless Steel
Alloy Steel	

*\* Special Materials available on request*

Standard Connection Sizes	Suction	Discharge
Q1609-Q1618	4.0	2.0
Q1620-Q1628	6.0	3.0
Q1628-Q1636	8.0	4.0

*\* NPT Connections Available*

- Consult FMC for specific exceptions to API-674 and NACE standards.
- Consult FMC for any application where inlet pressures will exceed 10% of rated discharge pressure.
- Horsepower based on 90% mechanical efficiency. Actual application horsepower requirements can be calculated using the equation:  $BHP = (GPM * PSI) / (1714 * 0.90)$
- Direction of rotation is the top of the crankshaft towards the fluid head.

## Q16 Performance Table

Pump Model	Plunger Diameter (in)	Displacement (GAL/REV)	Pressure (PSI)	Pump Capacity (GPM) @ Input Speed (RPM)					
				100 RPM	200RPM	300RPM	350RPM	400RPM	425RPM
Q1609	1.125	0.0861	10,000	8.6	17	26	30	34	37
Q1610	1.250	0.1062	8,150	11	21	32	37	43	45
Q1612	1.500	0.1530	5,650	15	31	46	54	61	65
Q1614	1.750	0.2082	4,160	21	42	63	73	83	89
Q1616	2.000	0.2720	3,190	27	54	82	95	109	116
Q1618	2.250	0.3442	2,520	34	69	103	121	138	146
Q1620	2.500	0.4250	2,040	43	85	128	149	170	181
Q1622	2.750	0.5142	1,690	51	103	154	180	206	219
Q1624	3.000	0.6120	1,420	61	122	184	214	245	260
Q1626	3.250	0.7182	1,210	72	144	216	251	287	305
Q1628	3.500	0.8330	1,040	83	167	250	292	333	354
Q1630	3.750	0.9562	910	96	191	287	335	383	406
Q1632	4.000	1.0880	800	109	218	326	381	435	462
Q1634	4.250	1.2282	710	123	246	369	430	491	522
Q1636	4.500	1.3770	630	138	275	413	482	551	585

## Q16 NPSHr values for Disc Valves with 2-springs

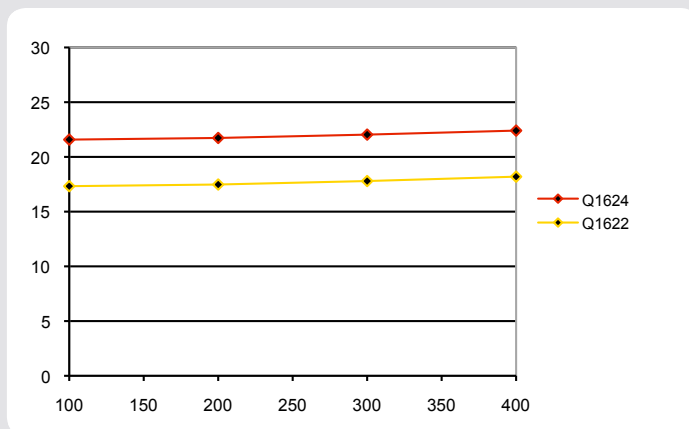

- Pump capacities shown are based on 100% volumetric efficiency.
- FMC recommends NPSHa (available) exceeds NPSHr (required) by 5 feet of water.
- Take special consideration when calculating NPSHa. Recalculate NPSHa after pump model has been selected for more accurate values.
- NPSHr values are in feet of water. If you are pumping a different liquid than water, convert the required NPSH from water to the liquid being pumped by dividing the published NPSHr value by the specific gravity of the liquid being pumped.
- FMC published NPSHr values are based on test data collected on specific pumps at the factory and are estimated values. Actual NPSHr values for an ordered pump can only be determined by a factor test. For NPSH critical applications, contact the factory for additional information and request an NPSHr test performed on your pump before shipment.

## Q16 Plunger Pump Data

198 BHP Continuous Duty (240 BHP Intermittent Duty)

### Forged Pump Engineering Dimensional Outline

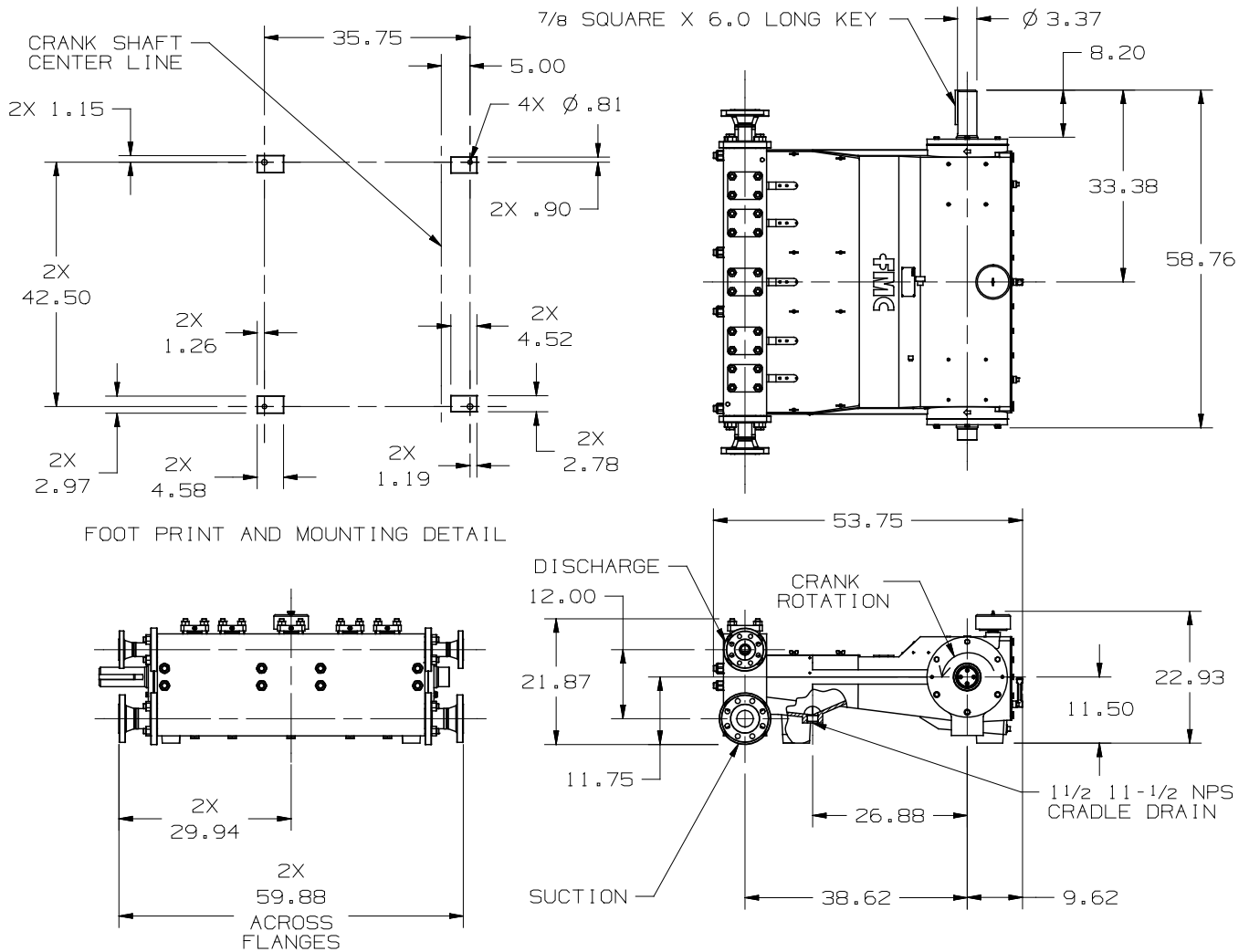

## Q16 Plunger Pump Data

198 BHP Continuous Duty (240 BHP Intermittent Duty)

### Cast Pump Engineering Dimensional Outline

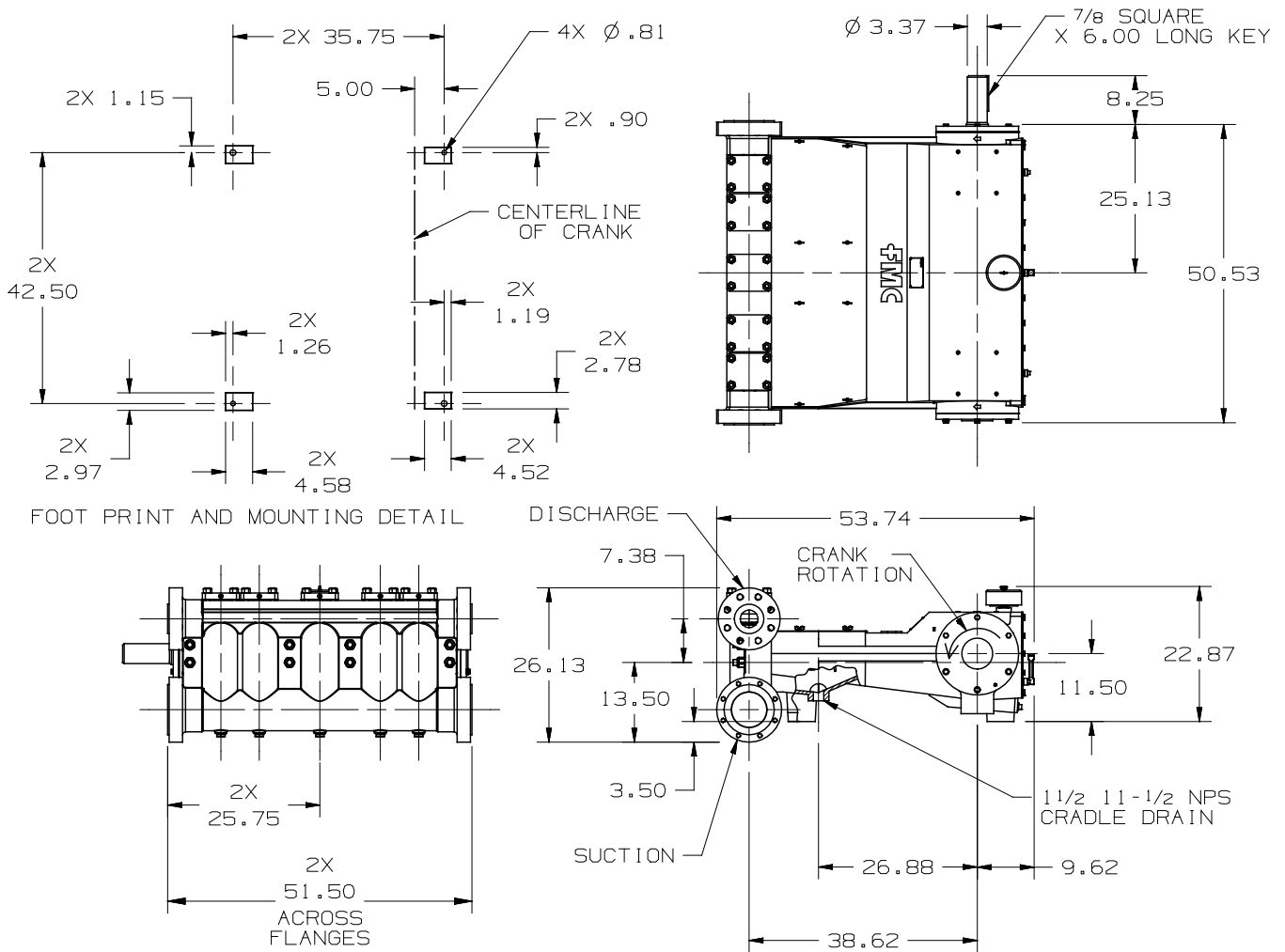

• Dimensions shown are for general sizing purposes and should not be used of construction. Contact FMC for actual dimensions of pump ordered.

• FMC reserves the right to modify this information without prior notice.

• Pump drawing dimensions in inches.

## Q18 Plunger Pump Data

265 BHP Continuous Duty (325 BHP Intermittent Duty)

### Forged ISO Drawing

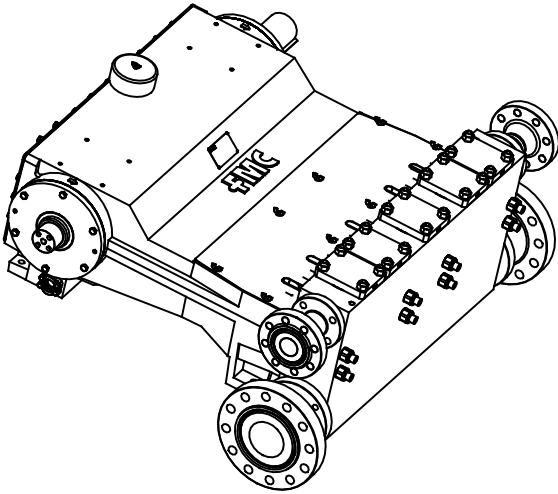

### Cast ISO Drawing

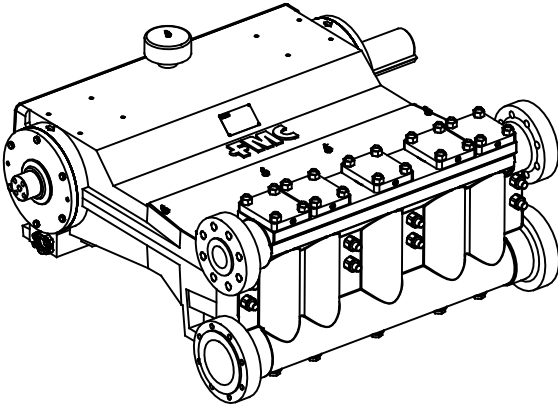

### Specifications

Pump Model	Q18
Design Standard	API-674, Second Edition
Configuration	Horizontal Quintuplex Plunger
Number of Plungers	5
Stroke Length	4.5 Inches
Frame Load Rating	12,500 lbs
Forged Fluid Cylinder Pressure Rating	10,000 psi
Cast Fluid Cylinder Pressure Rating	3,000 psi
Pump Weight (Average)	4,500 lbs
Intermittent Duty Speed Rating	400 RPM
Continuous Duty Speed Rating	330 RPM
API-674 Max Recommended Speed	330 RPM
Minimum Speed *	100 RPM
Mechanical Efficiency	90%
Lubrication System (Standard)	Splash, Gravity Return
Lubrication System (Optional)	Pressurized, Motor or Crank Driven
Lube Oil Capacity	16 Gallons
Lube Oil Type	SAE 30
Maximum Fluid Temperature	200 °F (400 °F Capability)
Minimum Fluid Temperature	-20 °F (-50 °F Capability)
Valve Types	Disc Valves, Abrasion Resistant Valves

*\* Slower RPM can be achieved with the addition of a pressurized lubrication system*

Forged Fluid End Material	Cast Fluid End Material
A105 Carbon Steel	Ductile Iron
A350-LF2 Carbon Steel	Nickel Aluminum Bronze
316L Stainless Steel	316L Stainless Steel
2205 Duplex Stainless Steel	2205 Duplex Stainless Steel
Alloy Steel	

*\* Special Materials available on request*

Standard Connection Sizes	Suction	Discharge
Q1811-Q1818	4.0	2.0
Q1820-Q1828	6.0	3.0
Q1830-Q1836	8.0	4.0

*\* NPT Connections Available*

- Consult FMC for specific exceptions to API-674 and NACE standards.
- Consult FMC for any application where inlet pressures will exceed 10% of rated discharge pressure.
- Horsepower based on 90% mechanical efficiency. Actual application horsepower requirements can be calculated using the equation:  $BHP = (GPM * PSI) / (1714 * 0.90)$
- Direction of rotation is the top of the crankshaft towards the fluid head.

## Q18 Performance Table

Pump Model	Plunger Diameter (in)	Displacement (GAL/REV)	Pressure (PSI)	Pump Capacity (GPM) @ Input Speed (RPM)					
				100 RPM	200RPM	300RPM	330RPM	350RPM	400RPM
Q1811	1.375	0.1446	8,400	15	29	44	48	51	58
Q1812	1.500	0.1721	7,100	17	34	52	57	60	69
Q1814	1.750	0.2343	5,200	23	47	70	77	82	94
Q1816	2.000	0.3060	4,000	31	61	92	101	107	122
Q1818	2.250	0.3873	3,100	39	78	116	128	136	155
Q1820	2.500	0.4781	2,500	48	96	143	158	167	191
Q1822	2.750	0.5785	2,100	58	116	174	191	202	231
Q1824	3.000	0.6885	1,800	69	138	207	227	241	275
Q1826	3.250	0.8080	1,500	81	162	242	267	283	323
Q1828	3.500	0.9371	1,300	94	187	281	309	328	375
Q1830	3.750	1.0758	1,100	108	215	323	355	377	430
Q1832	4.000	1.2240	1,000	122	245	367	404	428	490
Q1834	4.250	1.3818	900	138	276	415	456	484	553
Q1836	4.500	1.5491	800	155	310	465	511	542	620

### Q18 NPSHr values for Disc Valves with 2-springs

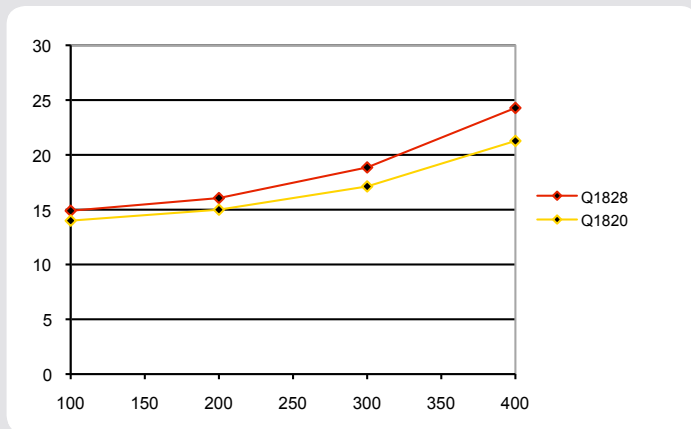

### Q18 NPSHr values for AR Valves with 1-springs

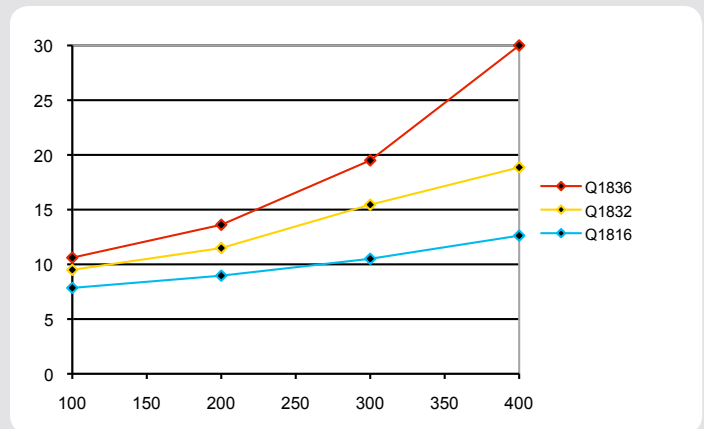

- Pump capacities shown are based on 100% volumetric efficiency.
- FMC recommends NPSHa (available) exceeds NPSHr (required) by 5 feet of water.
- Take special consideration when calculating NPSHa. Recalculate NPSHa after pump model has been selected for more accurate values.
- NPSHr values are in feet of water. If you are pumping a different liquid than water, convert the required NPSH from water to the liquid being pumped by dividing the published NPSHr value by the specific gravity of the liquid being pumped.
- FMC published NPSHr values are based on test data collected on specific pumps at the factory and are estimated values. Actual NPSHr values for an ordered pump can only be determined by a factor test. For NPSH critical applications, contact the factory for additional information and request an NPSHr test performed on your pump before shipment.

## Q18 Plunger Pump Data

265 BHP Continuous Duty (325 BHP Intermittent Duty)

### Forged Pump Engineering Dimensional Outline

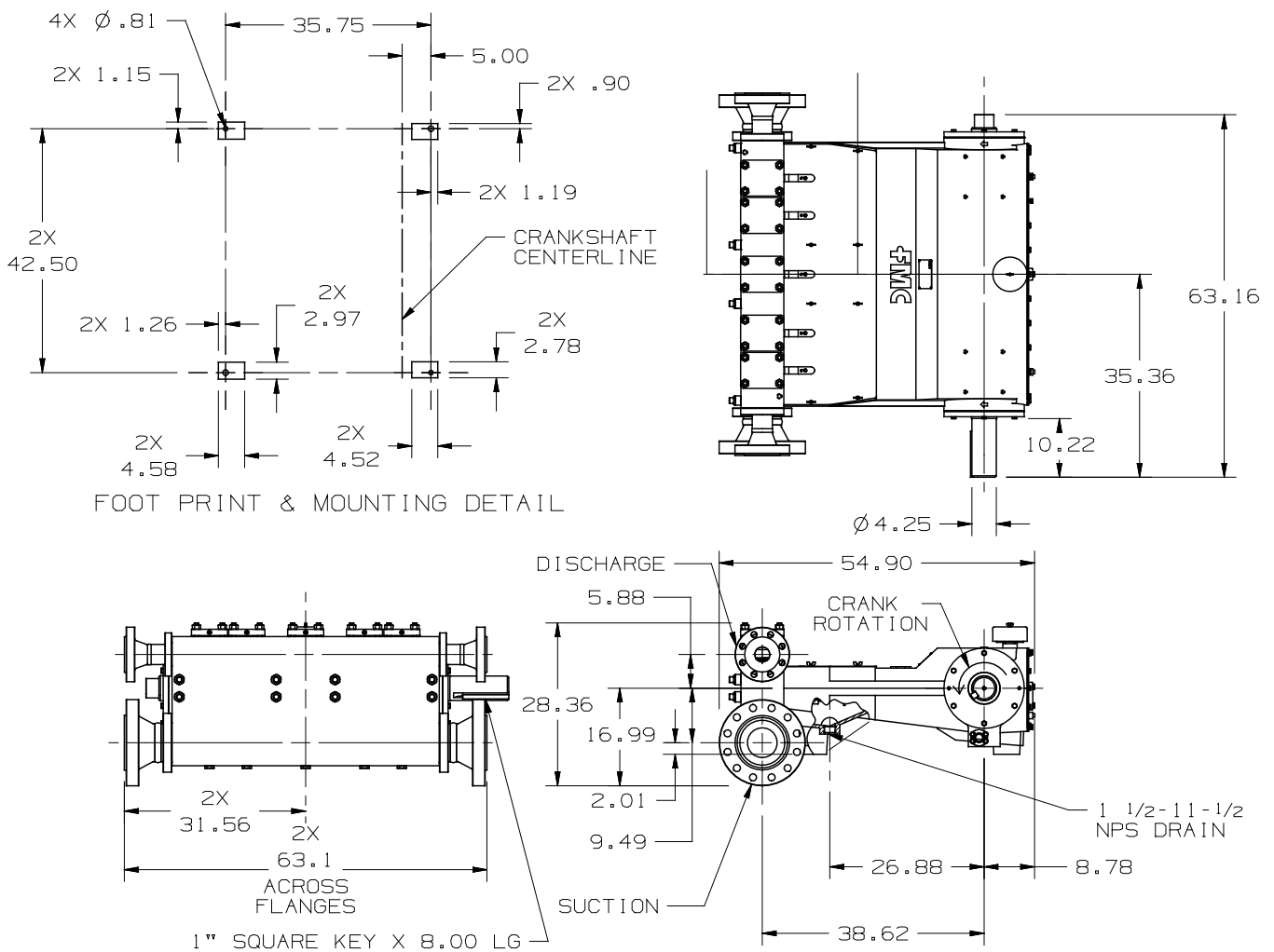



## Q28 Plunger Pump Data

650 BHP Continuous Duty (800 BHP Intermittent Duty)

### Forged ISO Drawing

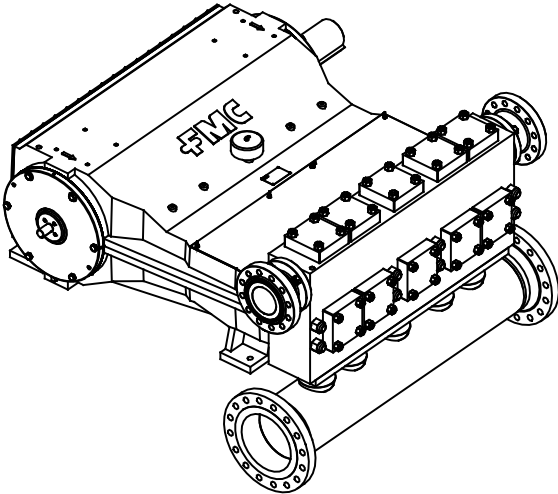

### Cast ISO Drawing

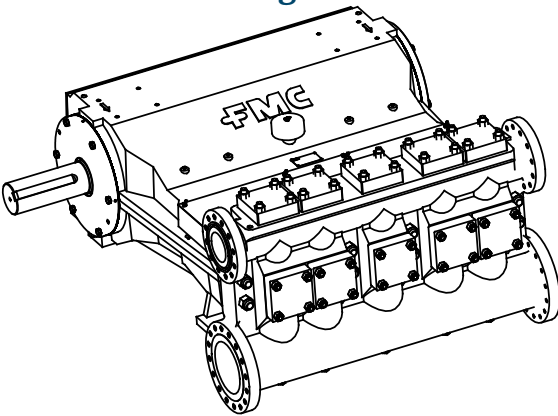

### Specifications

Pump Model	Q28
Design Standard	API-674, Second Edition
Configuration	Horizontal Quintuplex Plunger
Number of Plungers	5
Stroke Length	7.0 Inches
Frame Load Rating	27,500 lbs
Forged Fluid Cylinder Pressure Rating	10,000 psi
Cast Fluid Cylinder Pressure Rating	3,000 psi
Pump Weight (Average)	13,000 lbs
Intermittent Duty Speed Rating	300 RPM
Continuous Duty Speed Rating	240 RPM
API-674 Max Recommended Speed	240 RPM
Minimum Speed *	100 RPM
Mechanical Efficiency	90%
Lubrication System (Standard)	Splash, Gravity Return
Lubrication System (Optional)	Pressurized, Motor or Crank Driven
Lube Oil Capacity	40 Gallons
Lube Oil Type	SAE 30
Maximum Fluid Temperature	200 °F (400 °F Capability)
Minimum Fluid Temperature	-20 °F (-50 °F Capability)
Valve Types	Disc Valves, Abrasion Resistant Valves

\* Slower RPM can be achieved with the addition of a pressurized lubrication system

Forged Fluid End Material	Cast Fluid End Material
A105 Carbon Steel	Ductile Iron
A350-LF2 Carbon Steel	Nickel Aluminum Bronze
316L Stainless Steel	316L Stainless Steel
2205 Duplex Stainless Steel	2205 Duplex Stainless Steel
Alloy Steel	

\* Special Materials available on request

Standard Connection Sizes	Suction	Discharge
Q2814-Q2820	4.0	3.0
Q2814-Q2824	6.0	3.0
Q2826-Q2836	8.0	4.0
Q2838-Q2842	10.0	6.0
Q2844-Q2850	12.0	6.0

\* NPT Connections Available

- Consult FMC for specific exceptions to API-674 and NACE standards.
- Consult FMC for any application where inlet pressures will exceed 10% of rated discharge pressure.
- Horsepower based on 90% mechanical efficiency. Actual application horsepower requirements can be calculated using the equation:  $BHP = (GPM * PSI) / (1714 * 0.90)$
- Direction of rotation is the top of the crankshaft towards the fluid head.

## Q28 Performance Table

Pump Model	Plunger Diameter (in)	Displacement (GAL/REV)	Pressure (PSI)	Pump Capacity (GPM) @ Input Speed (RPM)					
				100 RPM	150RPM	200RPM	240RPM	250RPM	300RPM
Q2814	1.750	0.3644	10,000	36	55	73	87	91	109
Q2816	2.000	0.4760	8,750	48	71	95	114	119	143
Q2818	2.250	0.6024	6,920	60	90	120	145	151	181
Q2820	2.500	0.7437	5,600	74	112	149	178	186	223
Q2822	2.750	0.8999	4,630	90	135	180	216	225	270
Q2824	3.000	1.0710	3,890	107	161	214	257	268	321
Q2826	3.250	1.2569	3,310	126	189	251	302	314	377
Q2828	3.500	1.4577	2,860	146	219	292	350	364	437
Q2830	3.750	1.6734	2,490	167	251	335	402	418	502
Q2832	4.000	1.9040	2,190	190	286	381	457	476	571
Q2834	4.250	2.1494	1,940	215	322	430	516	537	645
Q2836	4.500	2.4097	1,730	241	361	482	578	602	723
Q2838	4.750	2.6849	1,550	268	403	537	644	671	805
Q2840	5.000	2.9750	1,400	297	446	595	714	744	892
Q2842	5.250	3.2799	1,270	328	492	656	787	820	984
Q2844	5.500	3.5997	1,160	360	540	720	864	900	1,080
Q2846	5.750	3.9344	1,060	393	590	787	944	984	1,180
Q2848	6.000	4.2840	970	428	643	857	1,028	1,071	1,285
Q2850	6.250	4.6484	900	465	697	930	1,116	1,162	1,395

### FMC Bolt-on Gearbox Ratios Available

6.17 : 1

7.30 : 1

9.57 : 1

- Pump capacities shown are based on 100% volumetric efficiency.
- FMC recommends NPSHa (available) exceeds NPSHr (required) by 5 feet of water.
- Take special consideration when calculating NPSHa. Recalculate NPSHa after pump model has been selected for more accurate values.
- NPSHr values are in feet of water. If you are pumping a different liquid than water, convert the required NPSH from water to the liquid being pumped by dividing the published NPSHr value by the specific gravity of the liquid being pumped.
- FMC published NPSHr values are based on test data collected on specific pumps at the factory and are estimated values. Actual NPSHr values for an ordered pump can only be determined by a factor test. For NPSH critical applications, contact the factory for additional information and request an NPSHr test performed on your pump before shipment.

**Q28 Plunger Pump Data**

650 BHP Continuous Duty (800 BHP Intermittent Duty)

**Forged Pump Engineering Dimensional Outline**

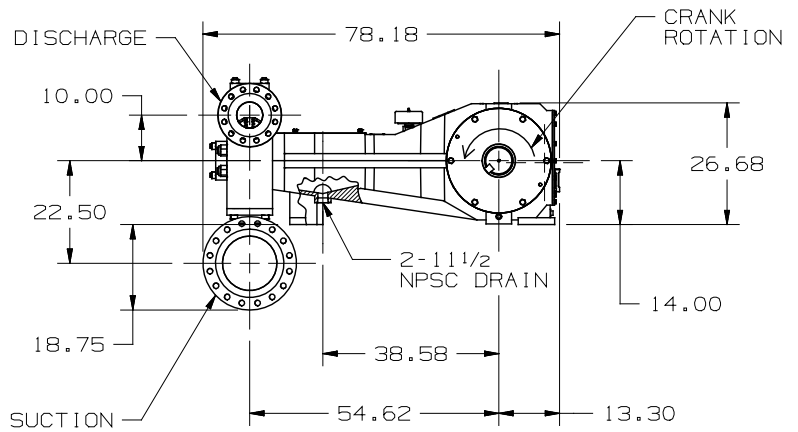
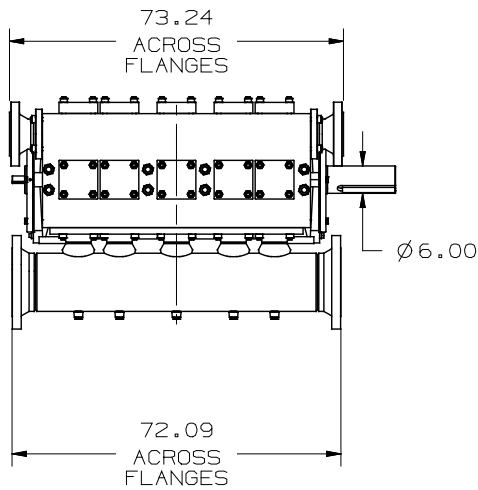
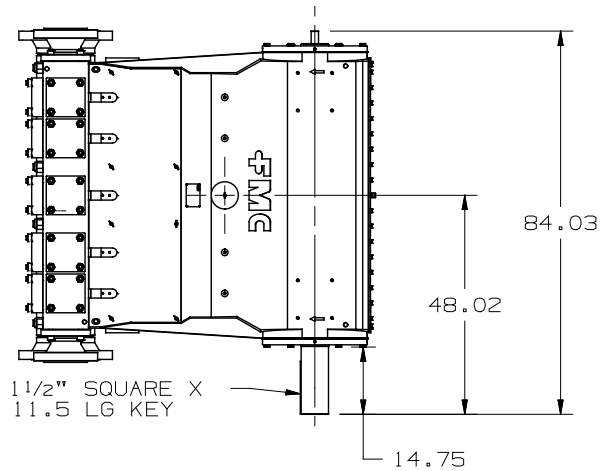
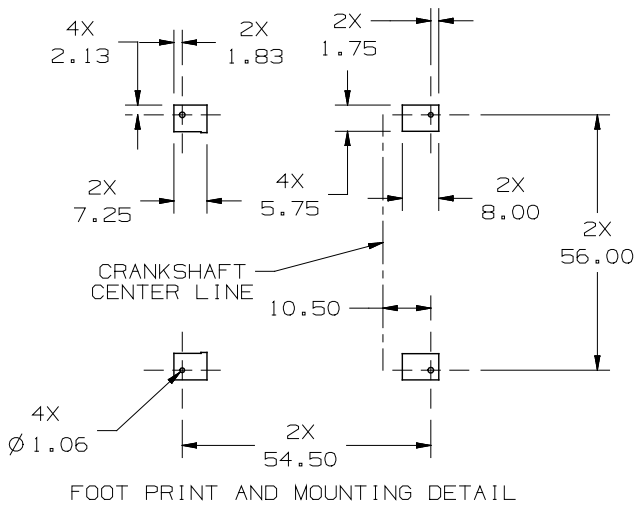



## Q32 Plunger Pump Data

700 BHP Continuous Duty (1,000 BHP Intermittent Duty)

### Forged ISO Drawing

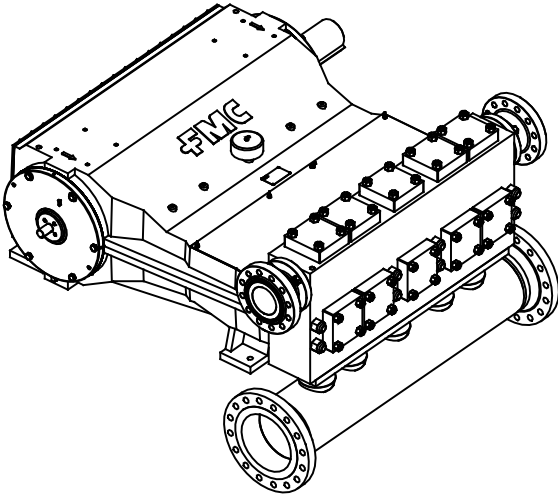

### Cast ISO Drawing

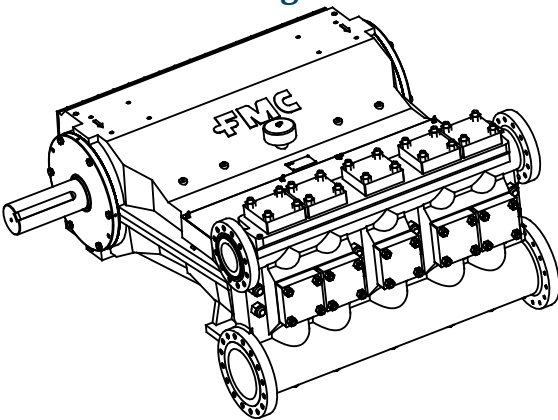

### Specifications

Pump Model	Q32
Design Standard	API-674, Second Edition
Configuration	Horizontal Quintuplex Plunger
Number of Plungers	5
Stroke Length	8.0 Inches
Frame Load Rating	30,000 lbs
Forged Fluid Cylinder Pressure Rating	10,000 psi
Cast Fluid Cylinder Pressure Rating	3,000 psi
Pump Weight (Average)	13,000 lbs
Intermittent Duty Speed Rating	300 RPM
Continuous Duty Speed Rating	210 RPM
API-674 Max Recommended Speed	210 RPM
Minimum Speed *	100 RPM
Mechanical Efficiency	90%
Lubrication System (Standard)	Splash, Gravity Return
Lubrication System (Optional)	Pressurized, Motor or Crank Driven
Lube Oil Capacity	40 Gallons
Lube Oil Type	SAE 30
Maximum Fluid Temperature	200 °F (400 °F Capability)
Minimum Fluid Temperature	-20 °F (-50 °F Capability)
Valve Types	Disc Valves, Abrasion Resistant Valves

*\* Slower RPM can be achieved with the addition of a pressurized lubrication system*

Forged Fluid End Material	Cast Fluid End Material
A105 Carbon Steel	Ductile Iron
A350-LF2 Carbon Steel	Nickel Aluminum Bronze
316L Stainless Steel	316L Stainless Steel
2205 Duplex Stainless Steel	2205 Duplex Stainless Steel
Alloy Steel	

*\* Special Materials available on request*

Standard Connection Sizes	Suction	Discharge
Q3214-Q3220	4.0	3.0
Q3214-Q3224	6.0	3.0
Q3226-Q3234	8.0	4.0
Q3236-Q3240	10.0	6.0
Q3242-Q3250	12.0	6.0

*\* NPT Connections Available*

- Consult FMC for specific exceptions to API-674 and NACE standards.
- Consult FMC for any application where inlet pressures will exceed 10% of rated discharge pressure.
- Horsepower based on 90% mechanical efficiency. Actual application horsepower requirements can be calculated using the equation:  $BHP = (GPM * PSI) / (1714 * 0.90)$
- Direction of rotation is the top of the crankshaft towards the fluid head.

## Q32 Performance Table

Pump Model	Plunger Diameter (in)	Displacement (GAL/REV)	Pressure (PSI)	Pump Capacity (GPM) @ Input Speed (RPM)					
				100 RPM	150RPM	200RPM	210RPM	250RPM	300RPM
Q3214	1.750	0.4165	10,000	42	62	83	87	104	125
Q3216	2.000	0.5440	9,550	54	82	109	114	136	163
Q3218	2.250	0.6885	7,500	69	103	138	145	172	207
Q3220	2.500	0.8500	6,125	85	128	170	179	213	255
Q3222	2.750	1.0285	5,025	103	154	206	216	257	309
Q3224	3.000	1.2240	4,250	122	184	245	257	306	367
Q3226	3.250	1.4365	3,620	144	215	287	302	359	431
Q3228	3.500	1.6660	3,125	167	250	333	350	417	500
Q3230	3.750	1.9125	2,720	191	287	383	402	478	574
Q3232	4.000	2.1760	2,390	218	326	435	457	544	653
Q3234	4.250	2.4565	2,110	246	368	491	516	614	737
Q3236	4.500	2.7540	1,890	275	413	551	578	689	826
Q3238	4.750	3.0685	1,690	307	460	614	644	767	921
Q3240	5.000	3.4000	1,530	340	510	680	714	850	1,020
Q3242	5.250	3.7485	1,390	375	562	750	787	937	1,125
Q3244	5.500	4.1140	1,260	411	617	823	864	1,029	1,234
Q3246	5.750	4.4965	1,160	450	674	899	944	1,124	1,349
Q3248	6.000	4.8960	1,060	490	734	979	1,028	1,224	1,469
Q3250	6.250	5.3125	980	531	797	1,063	1,116	1,328	1,594

### FMC Bolt-on Gearbox Ratios Available

6.17 : 1

7.30 : 1

9.57 : 1

- Pump capacities shown are based on 100% volumetric efficiency.
- FMC recommends NPSHa (available) exceeds NPSHr (required) by 5 feet of water.
- Take special consideration when calculating NPSHa. Recalculate NPSHa after pump model has been selected for more accurate values.
- NPSHr values are in feet of water. If you are pumping a different liquid than water, convert the required NPSH from water to the liquid being pumped by dividing the published NPSHr value by the specific gravity of the liquid being pumped.
- FMC published NPSHr values are based on test data collected on specific pumps at the factory and are estimated values. Actual NPSHr values for an ordered pump can only be determined by a factor test. For NPSH critical applications, contact the factory for additional information and request an NPSHr test performed on your pump before shipment.

## Q32 Plunger Pump Data

700 BHP Continuous Duty (1,000 BHP Intermittent Duty)

### Forged Pump Engineering Dimensional Outline

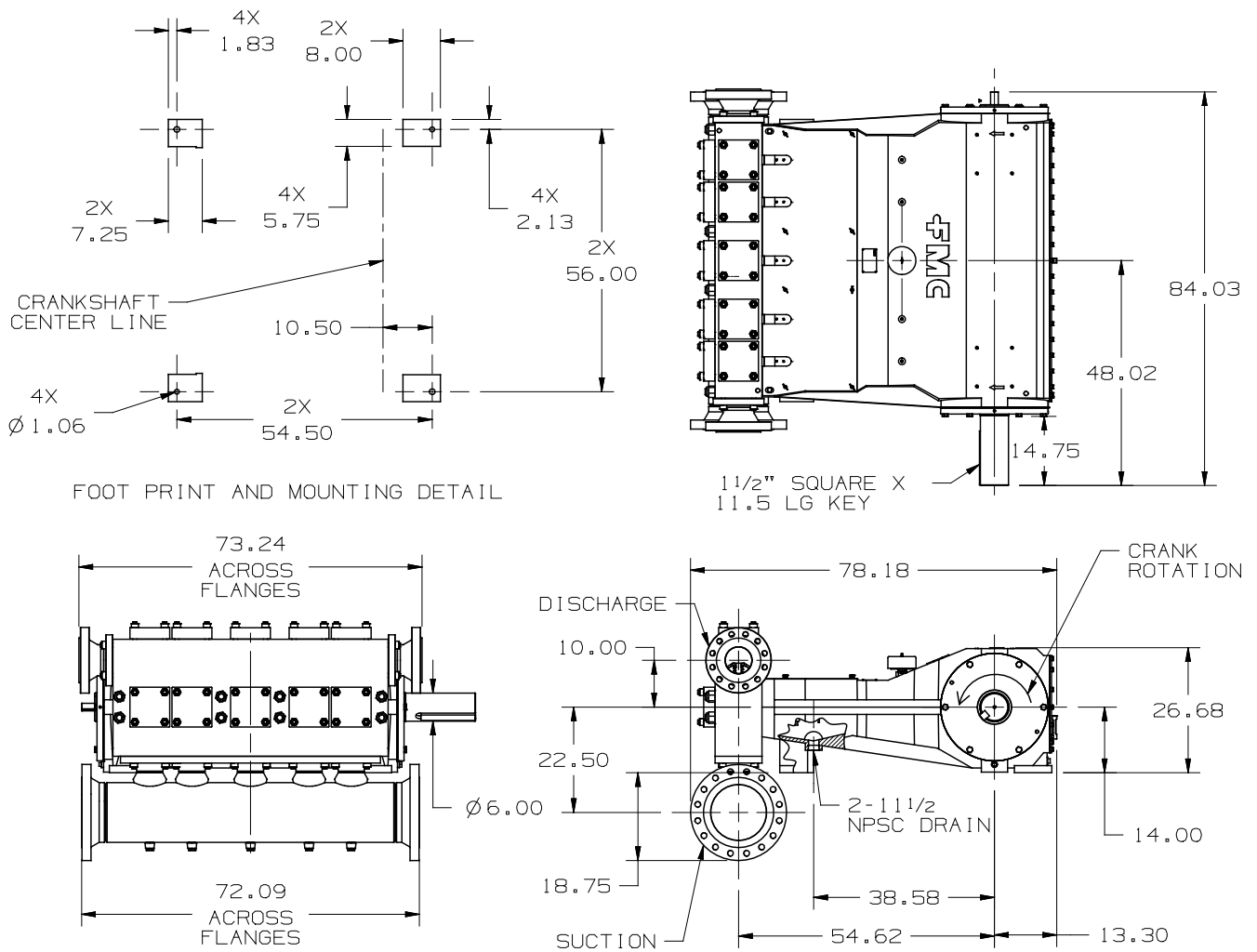

## Q32 Plunger Pump Data

700 BHP Continuous Duty (1,000 BHP Intermittent Duty)

### Cast Pump Engineering Dimensional Outline

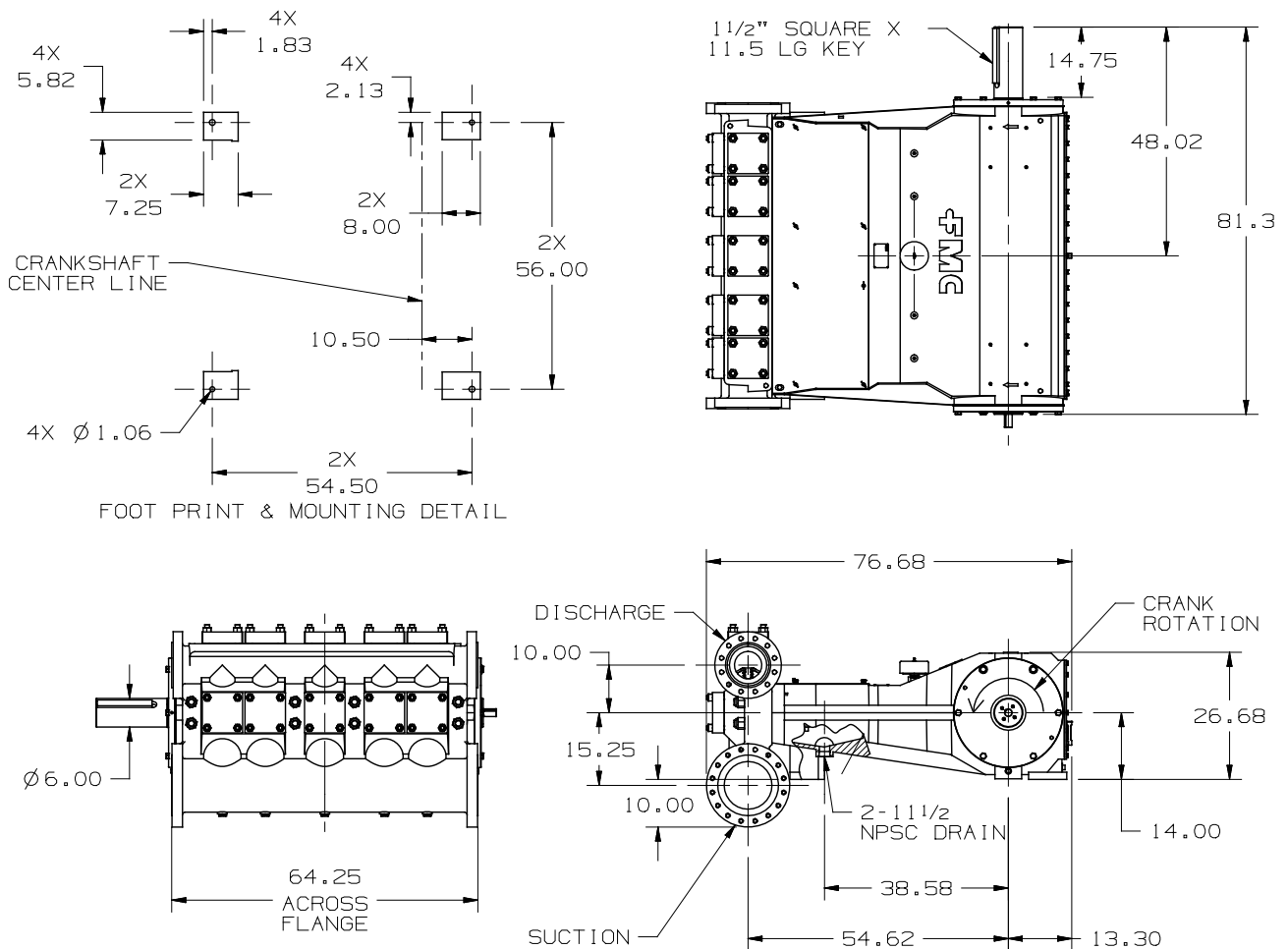

• Dimensions shown are for general sizing purposes and should not be used of construction. Contact FMC for actual dimensions of pump ordered.

• FMC reserves the right to modify this information without prior notice.

• Pump drawing dimensions in inches.

## Material Selection Chart for Plunger Pumps

Liquid	Fluid End (5)	Valves (7)	Plungers (3)	Packing (4)	Adjusting Nut (6)	Packing Lube (2)	Vaporless (8)
Amine-DEA	CS	DEL, TIT, or AR	Tungsten Coated SS	V-ring or Braided	SS	No	No
Amine-MEA	CS	DEL, TIT, or AR	Tungsten Coated SS	V-ring or Braided	SS	No	No
Carbon Dioxide (Dry or Wet)	CS	DEL, TIT, or AR	Tungsten Coated SS	V-ring or Braided	SS	Yes	No
Condensate:							
n-Butane/iso-Butane	CS or SS	DEL, TIT, or AR	Tungsten Coated SS	V-ring or Braided	AB	Yes	Yes
Ethane/Methane	CS or SS	DEL, TIT, or AR	Tungsten Coated SS	V-ring or Braided	AB	Yes	Yes
Liquid Propane Gas or Natural Gas Liquid	CS or SS	DEL, TIT, or AR	Tungsten Coated SS	V-ring or Braided	AB	Yes	Yes
Lean Oil	CS or SS	DEL, TIT, or AR	Tungsten Coated SS	V-ring or Braided	AB	Yes	Yes
Fuel Oil (Diesel/Kerosene)	CS	DEL, TIT, or AR	Tungsten Coated SS	V-ring	AB or SS	No	No
Glycol (Ethylene/Diethylene)	CS	TIT, or AR	Tungsten Coated SS	V-ring or Braided	AB or SS	No	No
Methanol	CS or SS	DEL, TIT, or AR	Tungsten Coated SS	V-ring or Braided	AB	Yes	Yes
Oil:							
Crude, Clean	CS	DEL, TIT, or AR	Tungsten Coated SS	V-ring or Braided	AB	No	No
Crude w/ Solids	CS	AR	Tungsten Coated SS	V-ring or Braided	AB	No	No
Crude w/ H <sub>2</sub> S	CS	DEL, TIT, or AR	Tungsten Coated SS	V-ring or Braided	SS	No	No
Hydraulic	CS	DEL, TIT, or AR	Tungsten Coated SS	V-ring or Braided	AB	No	No
Water:							
Hot/Boiler Feed	SS or NAB	DEL, TIT, or AR	Tungsten Coated SS	Braided	SS	Yes	No
Salt/Produced	SS or NAB	DEL, TIT, or AR	Tungsten or Ceramic	V-ring or Braided	SS	Yes	No
Salt/Produced w/ H <sub>2</sub> S	SS or NAB	DEL, TIT, or AR	Tungsten or Ceramic	V-ring or Braided	SS	Yes	No
Sea, Non-Aerated	SS or NAB	DEL, TIT, or AR	Tungsten or Ceramic	V-ring or Braided	SS	No	No
Sea, Aerated	DX	DEL, TIT, or AR	Tungsten or Ceramic	V-ring or Braided	SS	No	No

- The material selection charts are general recommendations.
- For more detailed or alternative recommendations, please consult FMC

# Material Selection Chart for Piston Pumps

Liquid	Fluid End (5)	Valves (7)	Liners (3)	Packing (4)
Drilling Mud	Ductile Iron	Ball or Disc	Steel Backed Ceramic	HSN or Super Gold
Fresh Water	Ductile Iron	Ball or Disc	Steel Backed Ceramic	HSN or Super Gold
Mine Water	Ductile Iron	Ball or Disc	Steel Backed Ceramic	HSN or Super Gold
<ul style="list-style-type: none"> <li>• The material selection charts are general recommendations.</li> <li>• For more detailed or alternative recommendations, please consult FMC</li> </ul>				

## Notes

1. CS = Carbon Steel

SS = Stainless Steel

DX = Duplex Stainless Steel

NAB = Nickel Aluminum Bronze

DEL = Delrin Disc Valves

TIT = Titanium Disc Valves

AR = Abrasion Resistant Valves
2. Packing Lube can be used when contamination of pumped liquid by packing lubricant is acceptable.
3. Tungsten coated stainless steel plungers are the most commonly used and well suited for all fluids. Solid ceramic plungers work well with abrasive fluids such as water applications but should not be used where thermal shock or flammable liquids or gases are present.
4. There are many variations of packings available for every application. Consult with FMC to determine the best option to suit your fluid type, temperature and lubrication needs.
5. Consult with FMC on the correct grade of CS or SS to use for your application.
6. Adjusting Nuts that are made from SS and used in SS stuffing boxes have an anti-seize coating to prevent galling.
7. Delrin disc valves are rated for pressures up to 3,500 psi and temperatures up to 150 degrees F. Titanium disc valves are rated for pressures up to 4,200 psi and temperatures up to 300 degrees F. AR valves with Viton inserts are rated for pressures up to 10,000 psi and temperatures up to 300 degrees F. AR valves with Urethane inserts are rated for pressures up to 10,000 psi and temperatures up to 160 degrees F. AR valves with metal to metal seats are rated for pressures up to 10,000 psi and temperatures higher than 160 degrees F.
8. Vaporless Stuffing Boxes should be used when pumping a flammable or hazardous liquid that should be prevented from leaking to atmosphere. In some cases, the addition of a sealed cradle is a good secondary barrier to leakage to atmosphere.

## Pump Options and Adders

### Fluid End Options

<b>Cradle Purge System</b>	Used in conjunction with a sealed cradle to purge the oxygen, flammable, or toxic gases from the cradle area with an inert gas such as Nitrogen. This would be used to prevent any hydrocarbon or other reactive exposure in the cradle area.
<b>Flushable Stuffing Box</b>	Ported stuffing box that allows a clean fluid to flush in and out to remove contamination that can damage wearable components prematurely or to cool the friction surfaces.
<b>Liner Wash System</b>	Used on piston pumps to wash the cylinder liners during pumping process to reduce the debris from pumping, cool friction surfaces, and extend component life.
<b>Lubricated Stuffing Box</b>	Ported stuffing box that allows a packing lubricant to be pumped directly into the packing area for better lubrication than an external drip. Used to reduce the friction on and extend the life of wearable components.
<b>Material Certification</b>	Documentation of the material certification of the pressure containing fluid end components.
<b>NACE</b>	Used in sour (high H <sub>2</sub> S) applications where certain materials are not allowed due to corrosion and/or reduction of material strength.
<b>Packing Lubricator</b>	Used in conjunction with a lubricated or vaporless stuffing box to provide forced lubrication to the stuffing box for reduced friction and extended life of the wearable components.
<b>Sealed Cradle</b>	Provides a complete seal of the cradle area to prevent all leakage from exiting the cradle area except from the appropriate drain points.
<b>Vaporless Stuffing Box</b>	Ported stuffing box with secondary packing that allows any leakage to be collected and sent to the vent manifold system. Packing lubrication is required for this option to lubricate and cool the secondary seals.
<b>Vent Manifold System</b>	Used in conjunction with the vaporless stuffing box to collect any leakage for removal, collection and/or disposal. The vent manifold system uses an orifice to build back pressure and a pressure switch to send a signal for alarm and/or shutdown in the case that the leakage exceeds the set limit.

### Valve Options

<b>AR Valves</b>	Abrasion resistant valves use a tapered seat, hard material, and an elastomeric seal to reduce the wear on the valve due to abrasive particles in the pumped fluid. When the temperature of the fluid exceeds the limits of the Urethane seal a Viton seal or metal-to-metal seat option is available.
<b>Ball Valves</b>	The self cleaning ball valve is used in applications where a fluid is pumped with abrasive and/or lost circulation material that can cause other valves to clog during operation.
<b>Disc Valves</b>	The spring loaded disc valve is the most common type of valve used in reciprocating pumps. Stainless steel, Delrin, or titanium discs are available for a variety of fluid types, temperatures, and pressures.
<b>Valve Tie Downs</b>	Used in extremely hot or cold applications where the potential exists for the valve to unseat due to material expansion or contraction.

### Plunger Packing Options

<b>Adjustable Braided Packing</b>	The braided packing is adjustable to allow the user to tighten the packing enough to reduce leakage to acceptable levels. The packing life is extended by not over tightening. Many types of material configurations are available for used with most fluid types.
<b>Header Ring</b>	Used in conjunction with v-ring packing as a wiper for abrasive fluid particles to prevent them from wearing the primary packing. Also provides the energizing force to preload the v-ring packing.
<b>High Temperature Packing</b>	Used in high temperature applications where the fluid temperature would decrease the life of standard packing materials.
<b>Spring Loaded V-ring Packing</b>	The v-ring packing is spring loaded to eliminate the need to adjust the packing tightness allowing for optimal packing life. Many types of material configurations are available for used with most fluid types.

# Pump Options and Adders

## Plunger Options

<b>Ceramic</b>	Ceramic plungers are very abrasion resistant, but due to susceptibility to thermal shock, they are not used recommended for use with any flammable or hazardous fluids. Used in abrasive water based applications like saltwater disposal.
<b>Chrome Oxide</b>	Recommended for use in amine or other fluids requiring restricted lubrication. One type of a chrome oxide coating is Rokide.
<b>Premium Tungsten Carbide</b>	Similar to the standard tungsten carbide plunger, but a higher grade of tungsten carbide coating.
<b>Tungsten Carbide</b>	The standard plunger option on a stainless steel base material with the best all-round resistance to abrasion and corrosion.

## Piston Seal Options

<b>Aflas</b>	Better for higher temperature applications.
<b>Carboxilated Nitrile</b>	Improved chemical and temperature applications.
<b>HSN</b>	Improved abrasion resistance.
<b>Neoprene</b>	Standard applications.
<b>Teflon Impregnated Kevlar</b>	Good for low lubricity fluids like water and mud. Good handling abrasive fluids.

## Piston Cylinder Options

<b>Ceramic</b>	Small pumps, Low-medium pressure, Superior abrasion resistance.
<b>Ceramic Coated Steel</b>	High pressure and resistance to thermal shock.
<b>Steel Backed Ceramic</b>	High pressure and superior abrasion resistance.

## Paint Options

<b>Standard FMC Blue Latex</b>	Standard paint available for general pumping applications.
<b>2-Coat Epoxy</b>	Used more frequently in on-shore oil and gas applications where extra coating protection is required.
<b>3-Coat Epoxy</b>	Used more frequently in off-shore oil and gas applications where extra coating protection is required.

# Pump Options and Adders

## Power End Options

<b>Crankshaft Extensions</b>	Crankshaft side designation is classified by viewing the power end while standing at the fluid end side. Left hand (LH) is standard. Right hand (RH) is optional.
<b>Double Extended Crankshafts</b>	Crankshaft extension on both sides of the power end. Typically available on most pumps and is for drive from either side of power end or to drive accessory equipment.
<b>Internal Gear Reducer</b>	In some piston pumps, the internal gear reduction reduces the need for use of belts and pulleys or external gear reducers. This allows for direct coupling to driver.
<b>Low Oil Level Switch</b>	Used to monitor the oil level in the power end of the pump and send a signal for alarm or shutdown in the case that the level falls too low for proper lubrication.
<b>Oil Coolers</b>	Used in conjunction with the power end pressure lube system to cool the lubrication oil before returning to the power end. Typically used in applications with hot ambient temperatures, hot pumped fluid temperatures, and/or high suction pressures.
<b>Oil Heater</b>	Used to maintain a minimum temperature of the power end lubrication to maintain a minimal lubrication oil viscosity in cold ambient temperatures while running or shutdown. An oil heater is also used to maintain a minimum power end temperature in humid environments to prevent water condensate forming in the power end and contaminating the lubrication oil.
<b>Power End Pressure Lube System</b>	This system force feeds lubricant to the critical bearing surfaces to insure lubrication, minimize friction, reduce heat generation, and extend wear component life. Used in applications with high suction pressures, slow running speeds (less than 100 crankshaft RPM), and/or high power end temperatures due to high ambient temperatures. Driven by electric motor (standard) or by pump crank.
<b>Pressure Switch (High and Low)</b>	Use in conjunction with the power end pressure lube system to send a signal for an alarm and/or shutdown in the case that the power end system drops below a minimal level indicating not enough pressure to feed the lubricant or above a maximum level indicating a clogged line or filter.
<b>Hydraulic Motor Mount with Splined Crankshaft</b>	On some pump models, a splined crankshaft and hydraulic motor mount adapter is available to reduce the need for extra coupling components allowing a direct mount of the hydraulic motor to the pump power frame. This will help reduce the cost, size and weight of the total pump system.
<b>Tachometer RPM Interface</b>	A tachometer interface for a magnetic pickup is available on most pump models to measure the rotations per minute (RPM) for input into monitoring and control systems.
<b>Thermocouple Interfaces</b>	Thermocouple interfaces for temperature sensors are available on most pump models to measure power end and bearing temperatures for input into a monitoring and control system.
<b>Vibration Switch</b>	Vibrations switches are available for direct mount to the pump power frame to monitor the pump vibrations and send a signal for an alarm and/or shutdown in the case that the vibration exceeds maximum limits.
<b>Wrist Pin Needle Bearings</b>	Available on most pump models and used in applications with high suction pressure and/or high ambient temperature applications to allow for better lubrication on the wrist pin area.

## Accessory Options

<b>Bolt-on Gearbox</b>	Available on some pump models to allow for direct mounting of a gearbox to reduce the overall cost, size and weight of a pump system. This allows the direct coupling of the drive to the pump reducing the extra components needed to couple with an external gear reducer or belts and pulleys.
<b>Hydraulic Motors</b>	Used in conjunction with hydraulic motor mounts with splined shafts to directly mount the hydraulic motor to the power end thus reducing the overall cost, size and weight of a pump system.
<b>Packing Lube Tank</b>	Used in conjunction with a packing lubrication system to provide an extended storage of packing lubricant that can gravity feed the packing lubricator reservoir. Without the packing lube tank, the packing lubricator must be checked daily, but with the packing lube tank, it will maintain a multiple day supply (typically 20-30 days depending on tank size and feed rate).
<b>Relief Valve</b>	Positive displacement pumps require a pressure relief valve on the discharge piping between the pump and any block valves. The relief valve is to bleed pressure and fluid flow to prevent injury to personnel, damage to the pump and/or damage to the pump system.
<b>Suction and Discharge Pulsation Dampeners</b>	Used to attenuate pressure and fluid flow variations created by normal operation of the reciprocating pump. Pulsation dampeners are available in several types, configurations, and sizes to meet most application attenuation requirements.

# Pump Options and Adders

## Testing Options - Certified or Witnessed Certified

<b>Mechanical Run Test</b>	All FMC pumps have mechanical run tests to insure the material, manufacturing, and assembly quality of the pump assembly. The test is run at the maximum speed and rated pressure for a specified minimum time based on pump model.
<b>Hydrostatic Fluid Cylinder Test</b>	When required by customer specifications, or API Standards, fluid cylinders will be hydrostatically tested. All fluid cylinders for API pumps with suction and discharge flanges are to be hydrostatically tested. Fluid cylinders are tested to 1.5 times its respective rated suction and discharge pressure for 30 minutes.
<b>Performance Test</b>	When required by customer specifications, pumps will have full performance tests that measure and record specific data that allows comparison of actual input and output parameters to determine pump efficiencies. Typically run at the normal operating condition of the application provided by the customer for 1 hour.
<b>NPSHr Test</b>	When required by customer specifications, net positive suction head required (NPSHr) test is the factory test to measure the minimum amount of suction pressure required for the pump to operate with no more than a 3% reduction in volumetric efficiency due to cavitation. Typically the NPSHr test is run at the normal operation condition of the application provided by the customer. This test can be repeated up to 5 total points for curve generation when required by the customer.
<b>FAT/String Test</b>	When required by customer specifications, final acceptance tests (FAT) or string tests will test pumps and drivers which are mounted on skids or bases and coupled together by power transmission devices. Auxiliary components such as motor control equipment, pulsation and flow control devices may be tested along with the pump unit when required. The pump units is run to measure and record specific data that allows comparison of actual input and output parameters to determine pump efficiencies. Typically run at the normal operating condition of the application provided by the customer for 1 hour.

## Service Options

<b>Short Term Storage for Severe Environments</b>	Proper storage of your FMC pump will insure that it is ready for service when started. FMC pumps come from the factory without crankcase oil and are prepared for storage periods of up to six (6) months in proper environmental conditions. Indoor storage in a dry, temperature-controlled location is always recommended. If pumps are to be stored short term (less than six (6) months) in a severe environment, they should be prepared using the FMC procedures outlining "Short Term Storage for Severe Environments" to protect the power end components from rusting and seizing due to the lack of lubricant and/or preservative.
<b>Long Term Storage</b>	Proper storage of your FMC pump will insure that it is ready for service when started. FMC pumps come from the factory without crankcase oil and are prepared for storage periods of up to six (6) months in proper environmental conditions. Indoor storage in a dry, temperature-controlled location is always recommended. If the pump is to be stored, or is inactive, for periods in excess of six (6) months, it is necessary to prepare the pump as outlined by FMC's "Long Term Storage" procedure to protect the power end components from rusting and seizing due to the lack of lubricant and/or preservative.
<b>Engineering Application Training</b>	FMC provides a complete in-house engineering training course for design, application, and maintenance engineers on basic to advance practical concepts for the proper selection, installation and application of reciprocating pumps and systems.
<b>Maintenance Training</b>	FMC provides a complete in-house maintenance training course for the maintenance technician and manager for reciprocating pumps and pump systems.
<b>Pump Commissioning</b>	Commissioning of a pump unit before start up at the application sight is crucial to the success of the pump over the lifetime of the pump system. This is also a good time for the maintenance staff to review the important aspects of the pump system. FMC and its distributors are available to help in the commissioning and start up process.

## Pump System Ideal Drawing

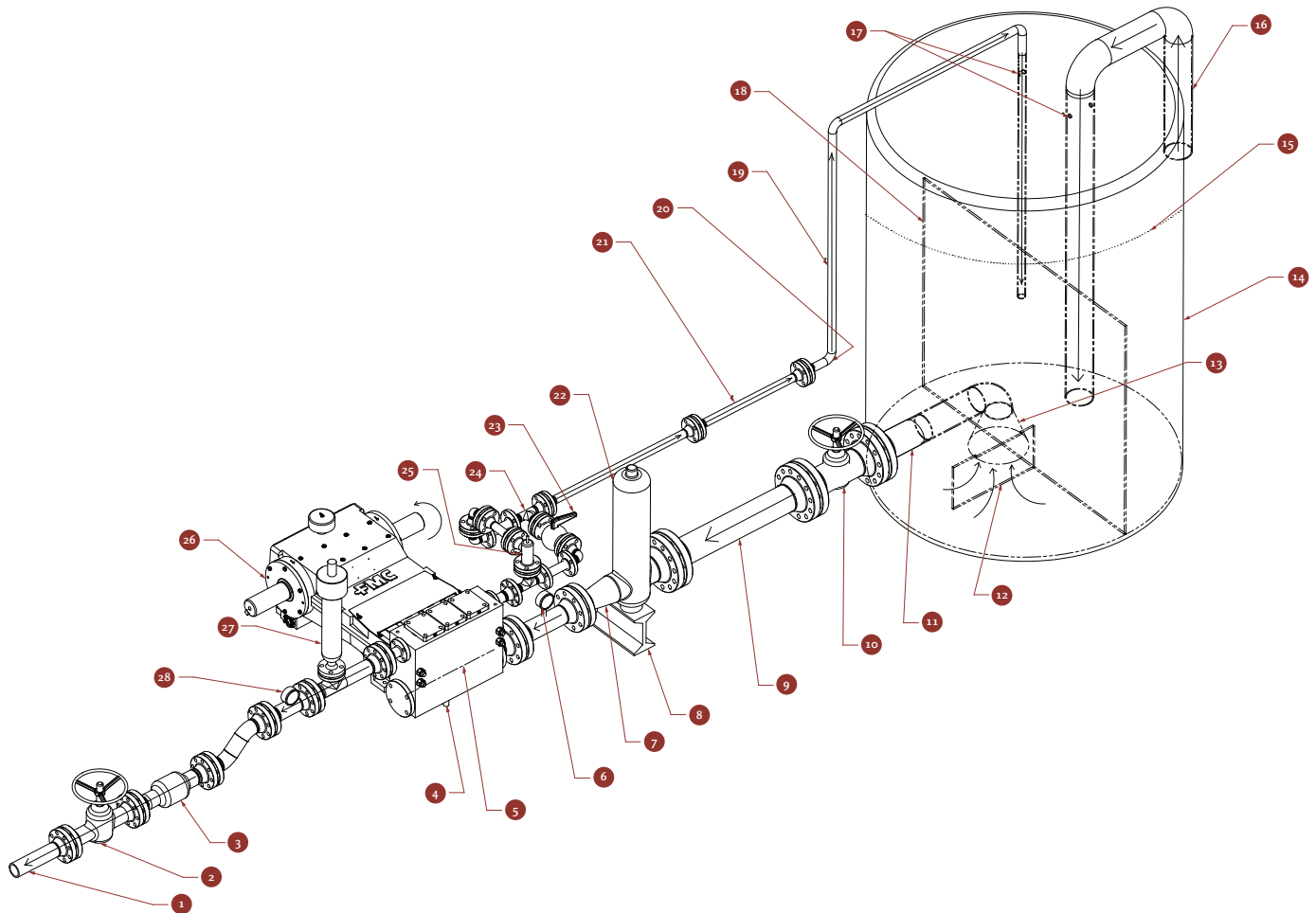

## Pump System Information

1	Discharge Line	15	Minimum fluid level
2	Full opening discharge line valve with body drain	16	Feed line
3	Full opening check valve	17	Small vent hole or vacuum breaker in tank above highest liquid level in tank
4	Cold weather drain and pressure relief valve	18	Completely submerged baffle plate separating incoming from outgoing liquid
5	Center line of suction	19	By-pass line and relief line returning to the supply tank
6	Pressure gauge with snubber or block valve	20	Low point drain valve
7	Eccentric reducer with flat side up	21	Expansion joint
8	Supports to relieve strains and minimize vibration	22	Suction pulsation dampener located as close to the pump as possible if used
9	Flexible hose or expansion joint	23	Needle or choke bypass valve to expel air in pump prior to loading
10	Full opening suction (inlet) line valve with body drain located near tank	24	Tee
11	Low point drain valve	25	Full opening relief valve or burst disc set no higher than 1.25 times the maximum plunger working pressure
12	Vortex splitter and support	26	Plunger pump with dual suction and dual discharge connections (Driver and foundation not shown)
13	Suction bell designed for low fluid entry velocity. (May include foot valve if desirable)	27	Discharge pulsation dampener located as close to pump as possible - if used
14	Fluid supply tank	28	Pressure gauge and block valve

## Reference Calculations

$$\text{Plunger Displacement [GPR]} \quad \text{GPR} = d^2 \times S \times N_p \times 0.0034$$

$$\text{Pump Displacement [GPM]} \quad \text{GPM} = \frac{(\text{RPM} \times \text{GPR} \times \text{VE})}{100}$$

$$\text{Piston/Plunger/Rod Load [lbf]} \quad \text{RL} = A_p \times \text{PSI}$$

$$\text{Fluid Velocity [ft/sec]} \quad \text{FV} = \frac{(\text{GPM} \times 0.321)}{\text{FA}}$$

$$\text{Flow Area of Pipe [in}^2\text{]} \quad \text{FA} = d^2 \times 0.7854$$

$$\text{Static Head of Liquid [ft of water]} \quad \text{H}_s = \frac{(2.31 \times \text{PSI})}{\text{S.G.}}$$

$$\text{Acceleration Head [ft of water]} \quad \text{H}_a = \frac{(\text{L} \times \text{V} \times \text{N} \times \text{C})}{(\text{K} \times \text{g})}$$

$$\text{NPSHa [ft of water]} = \text{H}_s + \text{P}_a - \text{P}_v - \text{H}_f - \text{H}_a$$

$$\text{Absolute Viscosity [cp]} = \text{S.G.} \times \text{cSt}$$

$$\text{Kinematic Viscosity [cSt]} = (0.22 \times \text{SSU}) - \frac{180}{\text{SSU}}$$

$$\text{Torque [ft-lb]} \quad \text{T} = \frac{(\text{hp} \times 5252)}{\text{RPM}}$$

$$\text{Horsepower Calculation [hp]} \quad \text{HP} = \frac{(\text{GPM} \times \text{PSI} \times 100)}{(1714 \times \text{ME})}$$

$$\text{Net Horsepower Calculation} \quad \text{HP} = \frac{(\text{GPM} \times \text{PSI}_{\text{Discharge}} \times 100)}{1714 \times \text{ME}} - \frac{(\text{GPM} \times \text{PSI}_{\text{Suction}} \times (\text{ME} - 0.05))}{1714 \times 100}$$

## Abbreviations

<b>A<sub>p</sub></b>	Area of Piston or Plunger in Square Inches	<b>L</b>	Length in Inches
<b>C</b>	Constant (0.066 Triplex, 0.200 Duplex, 0.040 Quintuplex)	<b>ME</b>	Mechanical Efficiency (90% for non-internal gear reduction, 85% for internal gear reduction)
<b>d</b>	Diameter in Inches	<b>N</b>	Pump Speed (RPM)
<b>FA</b>	Flow Area	<b>N<sub>p</sub></b>	Number of Pistons or Plungers
<b>FV</b>	Fluid Velocity	<b>P<sub>a</sub></b>	Atmospheric Pressure in Feet of Water
<b>g</b>	Gravity (32.2 ft/sec)	<b>P<sub>v</sub></b>	Vapor Pressure in Feet of Water
<b>GPM</b>	Gallons per Minute	<b>PSI</b>	Pounds per Square Inch
<b>H<sub>a</sub></b>	Static Head in Feet of Water	<b>S</b>	Stroke-Length in Inches
<b>H<sub>f</sub></b>	Friction Loss in Feet of Water	<b>S.G.</b>	Specific Gravity
<b>H<sub>s</sub></b>	Static Head in Feet of Water	<b>V</b>	Velocity of Fluid (Same as FV)
<b>K</b>	Constant (1.4 Water, 2.5 Hydrocarbons)	<b>VE</b>	Volumetric Efficiency

## Common Conversions

Convert From	To	Multiply By
Feet	Meter	0.3048
Inch	Millimeter	25.4
Square Inches	Square Centimeter	0.000645
Square Feet	Square Meter	0.09290
Gallons	Liter	3.785
Gallons	Cubic Meter	0.003785
Barrel (oil)	Gallons	42
PSI	Kilopascal	6.895
Bar	Kilopascal	100
Bar	PSI	14.504
Feet/Second	Meter/Second	0.3048
Horsepower	Kilowatt	0.746
Foot-Pound	Newton-Meter	1.356
Kilogram-Meter	Newton-Meter	9.807
Foot of Water	PSI	0.4335

## Warning & Safety instructions

FMC Technologies can not anticipate all of the situations a user may encounter while installing and using FMC Technologies products. Therefore, the user of FMC Technologies products **MUST** know and follow all applicable industry specifications on the safe installation and use of these products. Refer to FMC Technologies product catalogs, product brochures and installation, operating and maintenance manuals for additional product safety information or contact FMC Technologies at 800/772-8582

### WARNING: FAILURE TO FOLLOW THESE WARNINGS COULD RESULT IN SERIOUS INJURY OR DEATH!

- 1 Do not mix or assemble components, parts or end connections with different pressure ratings. Mismatched parts may fail under pressure.
- 2 Do not use or substitute non FMC Technologies components or parts in FMC Technologies products and assemblies.
- 3 Do not strike, tighten or loosen pressurized components or connections.
- 4 Do not exceed the rated working pressure of the product.
- 5 Complete and proper make-up of components and connections is required to attain rated working pressure.
- 6 Do not use severely worn, eroded or corroded products. Contact FMC Technologies for more information on how to identify the limits of erosion and corrosion.
- 7 Follow safe practices when using products in overhead applications. Products not properly secured could fall.
- 8 Select only appropriate product and materials for the intended service:
  - Do not expose standard service products to sour gas fluids. (Refer to NACE MR-0175.) Do not interchange sour gas components with standard service components.
  - Use appropriate safety precautions when working with ferrous products in below freezing temperatures. Freezing temperatures lower the impact strength of ferrous materials.
- 9 Follow manufacturers instructions and Material Safety Data Sheet directions when using solvents.
- 10 Make certain that personnel and facilities are protected from residual hazardous fluids before disassembly of any product.
- 11 If any leakage is detected from FMC Technologies products, take them from service immediately to prevent potential damage and personal injury.

### SAFETY INSTRUCTIONS

The applications of FMC Technologies products are in working environments where general personnel safety procedures and policies **MUST** be followed. Always use appropriate protective equipment in high pressure, extreme temperature or severe service applications.



## FMC Technologies

manufactures its line of Bean® Piston Pumps, FMC Plunger Pumps, and FMC Aqua Pumps at its Stephenville, Texas facility. This facility also manufactures precision swivels, valves, and manifolds.

### *Physical Plant*

The Stephenville plant was constructed in 1980 and expanded in 1984, 1987, and 1996. Situated on a 44-acre site, this modern facility is comprised of 220,000 square feet of manufacturing space and 48,000 square feet of customer service, production support and engineering offices. The facility utilizes the latest in CNC machining centers, production planning systems, CAD/CAM systems and order and distribution systems. This operation employs more than 480 manufacturing and support personnel.

### *Quality Assurance*

The Stephenville facility has been approved to the ISO 9001 Standard since 1989. The plant uses a Total Quality Assurance (TQA) program that utilizes:

- Quality Planning
- Material Auditing and Traceability
- Hydrostatic testing
- Pump Efficiency Testing
- Non-destructive Materials Testing CMA I
- Process and Product Inspections
- Cost-of-quality Reporting
- Participative Quality Improvement Teams

### *Engineering Capabilities*

The Stephenville product and manufacturing engineering staff has experience in fluid mechanics, material sciences, and mechanical design using:

- CAD/CAM (Computer Aided Design/ Computer Aided Manufacturing)
- CAE (Computer Aided engineering)
- FEA (Finite Element Analysis)

### *Customer Service*

Even with the technological advances in place at the Stephenville facility, FMC Technologies recognizes that the final product is dependent on people. FMC Technologies supports its customers through a trained and dedicated staff of customer service assistants. Advanced order management and materials planning systems are used to achieve the best opportunity of meeting customers delivery expectations.

### *Commitment*

At FMC Technologies, manufacturing, engineering, sales and marketing, and management all share a commitment to the customer. FMC Technologies strives to be an outstanding supplier to its customers. FMC Technologies wants to not only be your supplier today, but your supplier in the future too.

## Pump Selection Procedure

1. Determine your HP requirement using the following equation:

$$\text{HP} = \frac{\text{GPM} \times \text{PSI}}{1714 \times \text{Mechanical Efficiency}}$$

For preliminary sizing, use 90% for the mechanical efficiency, then adjust based on actual efficiency of pump selected.

2. Determine the duty cycle of your application. Continuous Duty is described as 8 hours or more operation per day, daily for extended periods of time.
3. Find the Pump Series under the first column with a HP rating that meets or exceeds the conditions of your application. Continuous HP is listed first. Intermittent HP is listed second.
4. Scan down the Rated Pressure column in the Pump Series selected until you find the last model whose maximum pressure rating exceeds the maximum pressure required by your application.
5. Check the appropriate capacity column (Continuous Duty Capacity or Intermittent Duty Capacity) to determine if the pump you selected meets the flow requirements of your application. If not, go to the next larger pump series and repeat Steps 4 & 5.
6. Determine the speed at which the pump will need to operate to produce the desired flow.

$$\text{RPM} = \frac{\text{Desired Flow (GPM)}}{\text{Displacement}}$$

### Notes:

1. Ratings are based on nominal speeds and pressures and may vary on FMC Technologies written approval.
2. Capacities and speeds indicated are based on 100% volumetric efficiency.
3. Continuous Duty is described as 8 hours or more operation per day, daily for extended periods of time.
4. Dimensions are approximate and based on standard pump models with cast fluid cylinders. Width is measured parallel to the axis of the drive shaft and does not include the shaft extension.



Member of AxFlow Group

0508 4 BBENG  
[www.brownbros.co.nz](http://www.brownbros.co.nz)