



1300 Series

SUBMERSIBLE NON-CLOG AND VORTEX PUMPS

 **LOWARA**
a xylem brand

Key Features

- Two versions - Non-Clog version and Vortex version
- Vortex impeller for maximum solids throughlet
- Three key models (1310, 1315, 1320)
- Available in Freestanding, Guiderrail or Replacement
- Easy to ID curve numbers
- pH 5.5-14
- 3 Phase 2.4kW-7.5kW locally stocked and supported
- Double mechanical seal
- Sturdy cast iron construction
- 10m cable as standard

Specifications

- Capabilities: up to 65 l/sec
- Head: up to 40m
- Power: up to 7.5kW
- 40°C Maximum liquid temperature



Wide operating performance envelope - 2Pole and 4Pole variants available

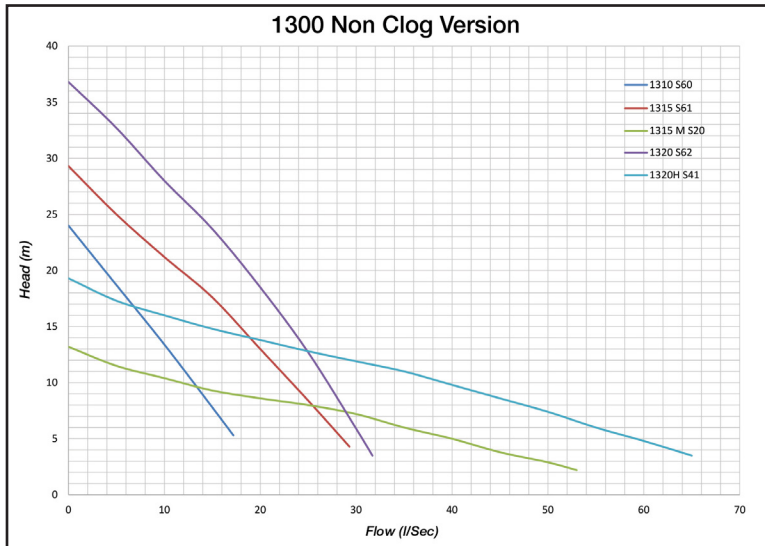

These curves are for reference only. Final selection should be made from individual performance charts.

Installation Kits

The Lowara 1300 Series is designed to fit your needs. You start with a bare pump and order the right kit depending on your desired installation method.

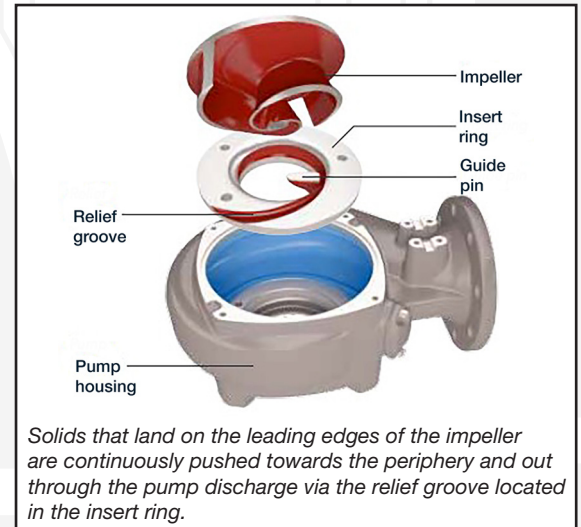
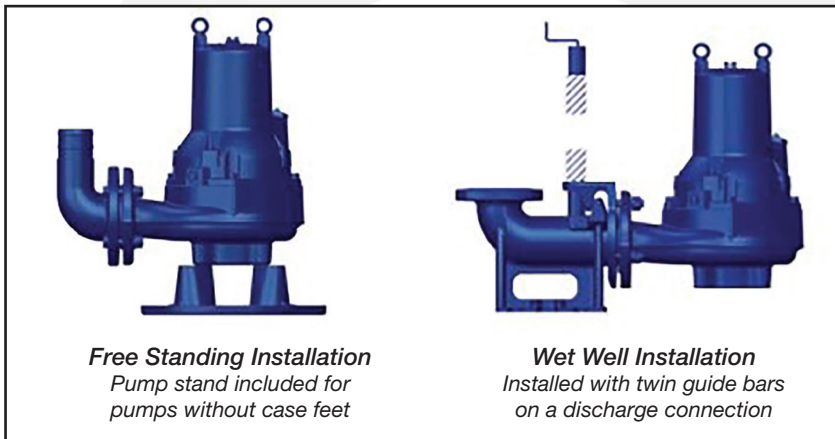

Applications



Dairy Effluent Pumping



Stormwater

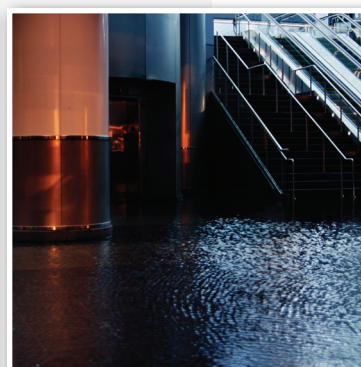

Drainage Water



Wastewater Pumping

Talk to your Area Sales Manager for more information about our 1300 Series pump range.