

# UNIVERSAL PRODUCT LINE

SERIES: 4223AX, 4323AX

STEEL EXTERNALS CONSTRUCTION

## FEATURES & BENEFITS

- Conforms fully to API 676 3rd Edition, NO EXCEPTIONS
- API 682 Category 1, 2 or 3 cartridge seals with optional API seal support plans
- Normalized and tempered steel casting construction
- ASME Class 300# RF flanged opposite ports with integral casing and bracket jackets
- Flanged casing drain with vent port for complete liquid removal prior to maintenance
- Non-destructive evaluation and performance testing required by API 676
- Robust design:
  - » 3mm corrosion allowance on pressure-containing parts
  - » 25,000 hour L-10 life on tapered roller bearings at maximum speed and pressure
  - » Easily adjusted end clearance to adjust for wear over time or application changes
  - » Machined mounting surfaces within 150  $\mu\text{m}/\text{m}$  (0.002 in./ft) in the same plane
  - » O-ring seals on casing joints instead of gaskets for maximum sealing effectiveness
- Viking Series 4223AX & 4323AX pumps carry a five year limited warranty

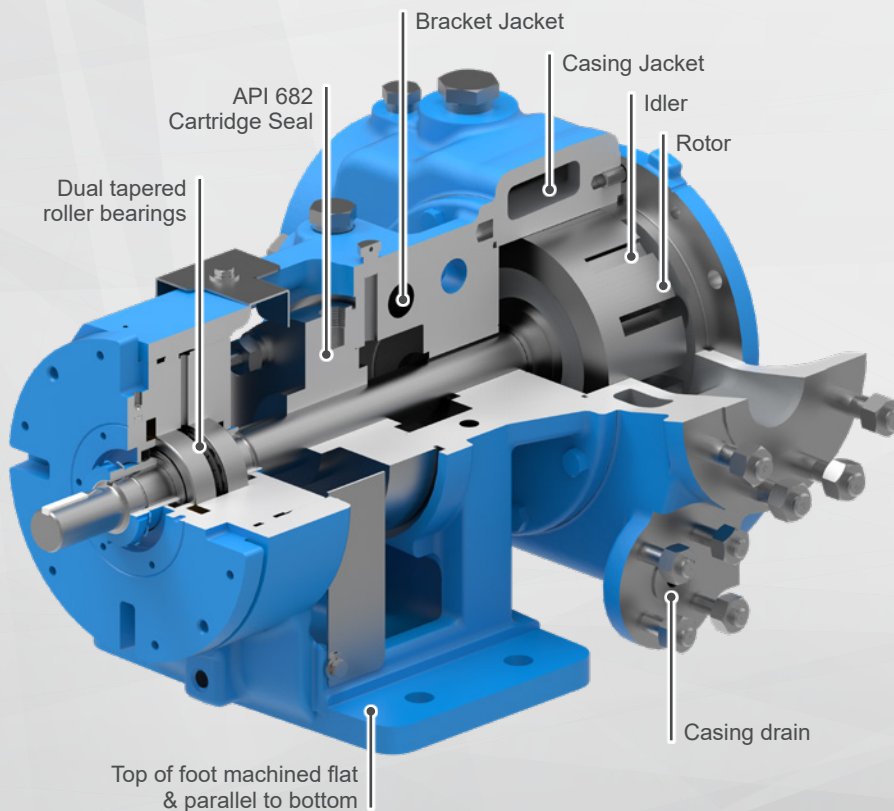
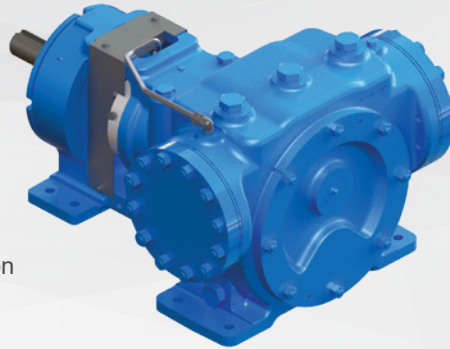

**VIKING PUMP**<sup>®</sup>



### CAPACITY

to 1,600 GPM  
(363 m<sup>3</sup>/h)



### PRESSURE

to 200 PSI  
(14 BAR)



### TEMPERATURE

-120°F to +800°F  
(-85°C to +430°C)



### VISCOSITY

28 to 2,000,000 SSU  
(0.1 to 440,000 cSt)



## PERFORMANCE

MODELS	SPECIFICATIONS				
	Performance			Standard Ports	
Jacketed	Max Speed, RPM	GPM	m <sup>3</sup> /h	Size, Inches	Type
HL4223AX	1750	30	6.8	1.5	Flange
KK4223AX	780	100	23	2	Flange
LS4223AX	640	200	45	3	Flange
Q4223AX	520	300	68	4	Flange
QS4223AX	520	500	114	6	Flange
N4323AX	350	600	136	6	Flange
R4323AX	280	1,100	250	8	Flange

## CURVES

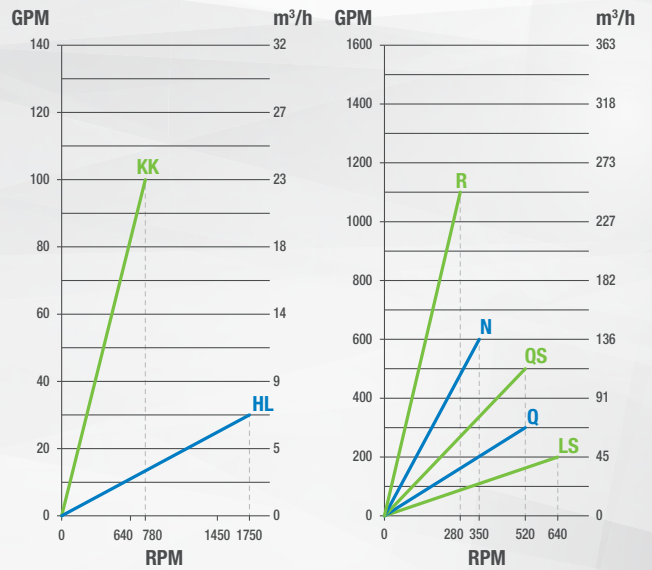

## PORTING

- Opposite (180°)
- Flanged (ASME)

## SEALING

- API 682 Category 1, 2, 3 Cartridge Seal with Seal Plans

## MOUNTING

- Foot Mount

## OPTIONS

- Labyrinth Seals
- Hardened Parts for Abrasive Applications
- Traceability
- Positive Material Identification
- Performance Testing
- Long Term Storage
- Paint (Options)
- NDE Testing
- NACE

## DRIVES

- Ⓡ Offset Gear Reducer Drive
- Ⓟ Purchased Gear Reducer Drive
- ⓓ Direct-Mounted Drive (HL Size)

## LIQUIDS

- Crude (Light, Heavy, Sour)
- Fuel Oils
- Petrochemicals
- Solvents
- Polymers
- Waxes

- Basic Chemicals
- Solvents
- Asphalt

# VIKING PUMP®

**VIKING PUMP, INC.**  
 A Unit of IDEX Corporation  
 406 State Street  
 Cedar Falls, Iowa 50613 U.S.A.  
[vikingpump.com](http://vikingpump.com)



**0508 4 BBENG**  
[www.brownbros.co.nz](http://www.brownbros.co.nz)

**United States**  
[vikingpump.com](http://vikingpump.com)  
 Cedar Falls, Iowa  
 Phone: (319) 266-1741

**Canada**  
[vikingpumpcanada.com](http://vikingpumpcanada.com)  
 Windsor, Ontario  
 Phone: (519) 256-5438

**Europe & Africa**  
[vikingpump.com](http://vikingpump.com)  
 Shannon, Ireland  
 Phone: +353 (61) 471933

**Asia-Pacific**  
[idexfmi-asia.com](http://idexfmi-asia.com)  
 China - Shanghai  
 Phone: +86-21-5241-5599  
 India - Mumbai  
 Phone: +91-22-6643-5563  
 Singapore  
 Phone: +65-6684-7305

**Middle East**  
[vikingpump.com](http://vikingpump.com)  
 Dubai, UAE  
 Phone: +971 4 2600300

**Latin America**  
[vikingpump.com](http://vikingpump.com)

**Australia & New Zealand**  
[vikingpump.com](http://vikingpump.com)

