

SPUR GEAR PRODUCT LINE

SERIES: SG-04, SG-05, SG-07, SG-10, SG-14

CAST IRON & DUCTILE IRON CONSTRUCTION

FEATURES & BENEFITS

- Needle bearings provide high pressure capabilities, sleeve bearing options available
- Close-coupled motor mount or foot bracket options to match space or motor requirements
- Double pump configurations offer two flow rates operating from a single power source, reducing equipment costs

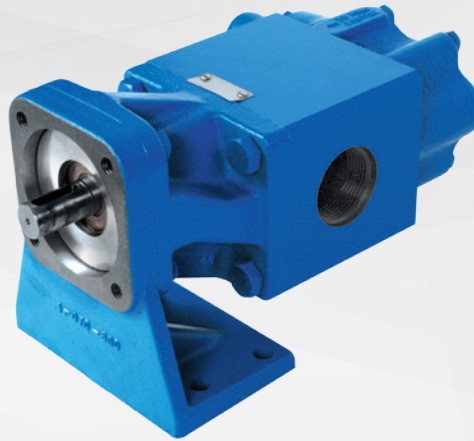

Two section pump (casing and bracket) on SG-10 & -14 reduces runout to keep shaft aligned for long seal life. Three section pump (casing, bracket and head) on SG-04, -05 & -07 allows for more precise machining for closest clearances on low flows.

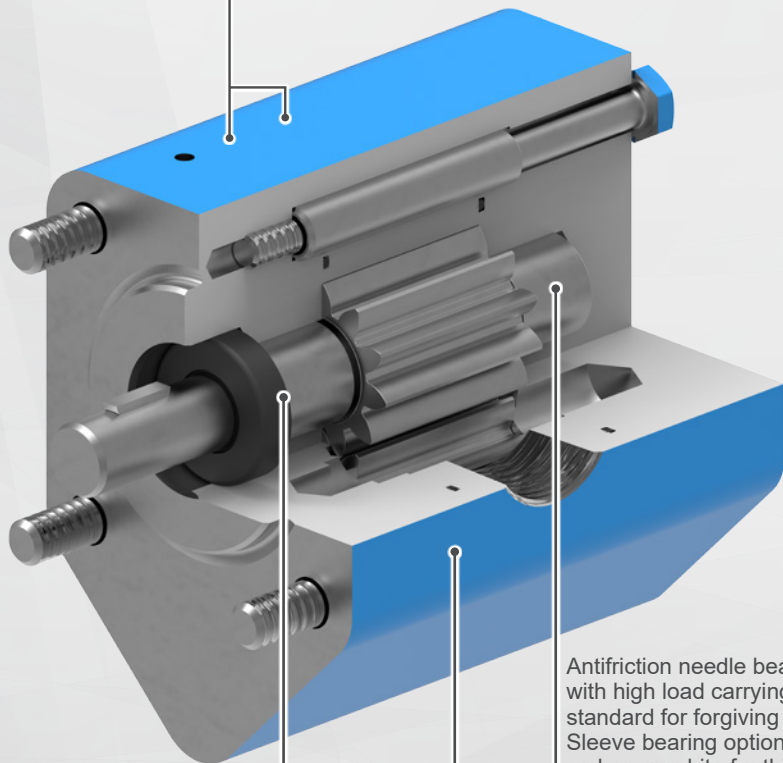

Sealing options include single lip seal, duplex lip seals with grease barrier, or single mechanical seal (all SG sizes). In addition, SG-10 and -14 offers pinned mechanical seal for high viscosity, and cartridge style single or double mechanical seals. Sealless mag drive option also available.

Antifriction needle bearings with high load carrying capacity standard for forgiving operation. Sleeve bearing options include carbon graphite for thin liquids, high temperature carbon, and silicon carbide for abrasives.

Hardened steel gears and shafts minimize wear. Spur-type gears minimize axial thrust for long seal life.

VIKING PUMP



CAPACITY

to 190 GPM
(719 LPM)



PRESSURE

to 500 PSI
(34 BAR)



TEMPERATURE

-40°F to +450°F
(-40°C to +230°C)



VISCOSITY

28 to 1,000,000 SSU
(1 to 250,000 cSt)

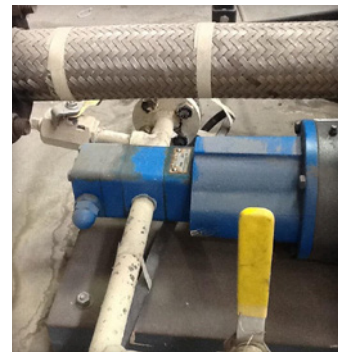

PERFORMANCE

MODELS			SPECIFICATIONS							
Lip Seal	Mechanical Seal	Mag Drive	Nominal Flow Range At 1750 RPM		Continuous Pressure		Intermittent Pressure		Standard Ports	
			GPM	LPM	PSI	BAR	PSI	BAR	Size, Inches	Type
SG-0417	SG-40417	—	0.06	0.23	500	34	750	52	0.375	NPT
SG-0418	SG-40418	—	0.14	0.53	500	34	1,250	86	0.375	NPT
SG-0425	SG-40425	—	0.18	0.68	500	34	1,500	103	0.375	NPT
SG-0470	SG-40470	—	0.5	1.89	500	34	1,500	103	0.375	NPT
SG-0518 ①	SG-40518	SG-80518	0.7	2.6	500	34	1,500	103	0.5	NPT
SG-0525 ①	SG-40525	SG-80525	1	3.8	500	34	2,500	172	0.5	NPT
SG-0535 ①	SG-40535	SG-80535	1.4	5.3	500	34	2,500	172	0.5	NPT
SG-0550 ①	SG-40550	SG-80550	2	7.6	500	34	2,500	172	0.5	NPT
SG-0570 ①	SG-40570	SG-80570	2.8	10.6	500	34	1,800	124	0.5	NPT
SG-0510 ①	SG-40510	SG-80510	4	15.1	500	34	1,250	86	0.5	NPT
SG-0514 ①	SG-40514	SG-80514	5.6	21.2	500	34	900	62	0.75	NPT
SG-0519 ①	SG-40519	SG-80519	7.6	28.8	200	14	400	28	0.75	NPT
SG-0528 ①	SG-40528	SG-80528	11.2	42.4	100	7	200	14	0.75	NPT
SG-0729	SG-40729	—	2.8	10.6	500	34	2,500	172	1	NPT
SG-0741	SG-40741	SG-80741	4	15.1	500	34	2,500	172	1	NPT
SG-0758	SG-40758	SG-80758	5.6	21.2	500	34	2,500	172	1	NPT
SG-0782	SG-40782	SG-80782	8	30.3	500	34	2,250	155	1	NPT
SG-0711	SG-40711	SG-80711	11.2	42.4	500	34	1,600	110	1	NPT
SG-0716	SG-40716	SG-80716	16	61	500	34	1,100	75	1	NPT
SG-0722	SG-40722	SG-80722	22	83	500	34	1,600	110	1.50 X 1.25	NPT
SG-0732	SG-40732	SG-80732	32	121	500	34	1,100	75	1.50 X 1.25	NPT
SG-1009	SG-41009	—	16	61	500	34	2,500	172	1	SAE Flange
SG-1013	SG-41013	SG-81013	25	95	500	34	1,900	131	1.5	SAE Flange
SG-1026	SG-41026	SG-81026	50	189	500	34	1,000	69	2	SAE Flange
SG-1420	SG-41420	SG-81420	70	265	500	34	1,100	76	2	SAE Flange
SG-1436	SG-41436	SG-81436	125	473	290	20	580	40	3	SAE Flange
SG-1456	SG-41456	SG-81456	190	719	190	13	380	26	4	SAE Flange

Integral pressure relief valve standard (single pump).

SG-05 & SG-07 models also available in Ductile Iron construction (SGN).

① SG-05 models available with UL 343 listing for fuel oil.

TYPICAL APPLICATIONS

- Pipeline Injection
- Pipeline Sampling
- Oil Polishing
- High Pressure Lubrication
- Hydraulics
- Fuels
- Lube Oils

PORTING

- Opposite (180°)
- NPT
- SAE O-Ring
- SAE Flange

SEALING

- Lip Seal
- Component Mechanical Seal
- Mag Drive

MOUNTING

- Foot Mount (with Footed Bracket)
- Motor Mount Bracket to IEC & NEMA Motors (Close-Coupled)
- Vertical Mount

OPTIONS

- Double Pump

DRIVES

- ⓓ Direct-Mounted Drive
- ⓑ Foot Bracket Mounted Drive
- Ⓜ Motor Mounted Drive
- Ⓜ4 Tang Motor Drive



(SG-0525 M4 Drive)

© Copyright 2017 Viking Pump, Inc. All Rights Reserved. Rev1217 | Form No. 1451



1300 4 BBENG

www.brownbros.com.au



0508 4 BBENG

www.brownbros.co.nz