



# MULTIPLUS 2

SA694.xx / SA697.xx



## **INSTRUCTION AND INSTALLATION MANUAL**

*Direct starting electronic control panel 2 motors for clean water and sewage with display and general disconnecting switch with door lock.*

1. General instructions for installing.....	21
2. Warnings.....	21
3. Application examples.....	22
4. Wiring diagrams	
4.1 Wiring diagram SA694.xx.....	23
4.2 Wiring diagram SA697.xx.....	24
5. Programming	
5.1 Fast programming.....	25
5.2 Application pressure booster.....	26
5.3 Application sewage.....	26
5.2 Application 4-20mA bar.....	27
5.3 Application 4-20mA meters.....	28
5.4 Advanced programming.....	29
6. General functioning of the control panel	
6.1 General functioning.....	31
6.2 Application pressure booster.....	31
6.3 Application clean water.....	32
6.4 Application sewage.....	32
6.5 Application 4-20mA bar.....	33
6.6 Application 4-20mA meters.....	33
7. Motors maintenance	
7.1 Motors maintenance programming.....	34
7.2 Motors maintenance messages.....	34
8. Data logger	
8.1 Alarm data logger.....	35
8.2 Event data logger.....	35
9. Troubleshooting and proposed solutions.....	36
10. Alarm messages.....	37
11. Disposal of electrical & electronic equipment.....	38
12. Declaration of conformity CE y UK.....	38
13. Warranty certificate.....	39

Make sure power supply is protected up to standard depending on application. The power of the motor has to be within the control panel's limits of use.

Install the control panel in an environment appropriate to its IP65 degree of protection. To fix the enclosure, use the brackets for the boxes 03-04 and the special predispositions for the remaining boxes. In order to fix the box, use the appropriate holes which are present or suggested on the bottom. Pay particular attention to not touching or damaging any components while fixing the box.

Eliminate whatever metal and/or plastic impurity which could happen to fall inside the box (screws, washers, dust...).

When connecting electric cables, follow the wiring diagrams.

When fixing the cables in the terminal board use tools of correct size to avoid damaging the metal feed clamps and their sockets.





Before acting upon anything inside, disconnect power supply. Regulation procedures must be carried out by qualified personnel. In case protections intervene verify the cause of the problem before resetting.

If necessary substitute the various components only with those having the same characteristics and components as the originals.

**It is the installer's duty to verify the device after the installation although it has already undergone regular testing by the manufacturer.**

**The manufacturer is released from all responsibilities for accidents to things or people, which derive from misuse of the devices by unauthorized personnel or from lack of maintenance and repair.**

2. WARNINGS

	<p><b>ELECTRIC SHOCKS</b></p> <p>Risk of electric shocks if not complied with the requirements.</p>
	<p><b>DANGER</b></p> <p>Risk of personal injury and property if not complied with the requirements.</p>
	<p><b>WARNING</b></p> <p>Before installing and using the product read this book in all its parts. Installation and maintenance must be performed by qualified personnel in accordance with current regulations. The manufacturer will not be held responsible for any damage caused by improper or prohibited use of this control panel and is not responsible for any damages caused by an incorrect installation or maintenance of the plant. The use of non-original spare parts, tempering or improper use, make the product warranty null.</p>
	<p><b>WARNING</b></p> <p>Be sure that the power of the motor is within the control panel range. Install the control panel in an environment appropriate to its IP 65 degree of protection. To operate inside the control panel use tools of correct size to avoid damaging the sockets.</p>
	<p><b>DANGER</b></p> <p>Before carrying out any intervention, make sure that the control panel is not powered. Do not attempt operations when the control panel is open. The control panel must be connected to an efficient earthing system. In order to fix the box use the appropriate holes present on the bottom, don't damage internal components and eliminate any working debris inside the box. In the case of protections eliminate the cause of the malfunction before the restoration.</p>

### 3. APPLICATION EXAMPLES

Below are some practical examples of applications that can be implemented with the **MULTIPLUS 2** control panel.

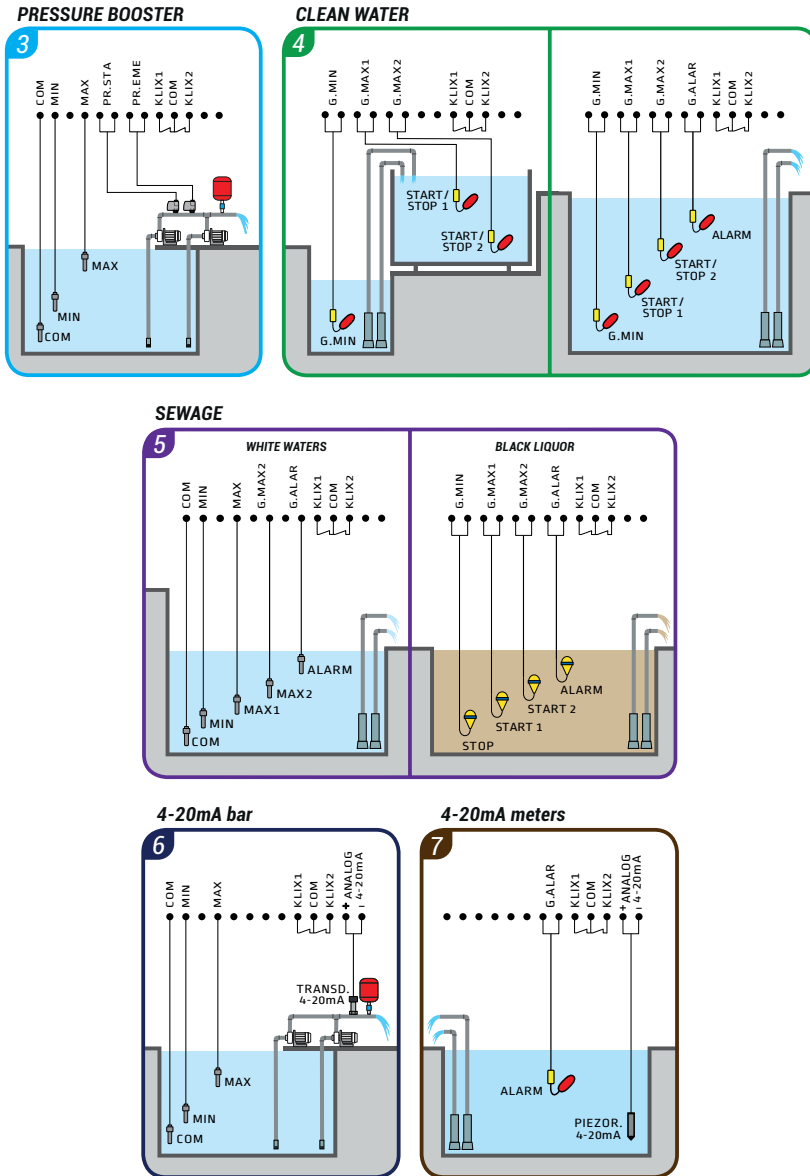

#### COMPONENTS KEY

- Float switch for clean water
- Float switch for sewage water
- Level probe

- Pressure switch
- 4-20mA pressure transducer
- 4-20mA piezoresistive probe

4.1 Wiring diagram SA694.xx

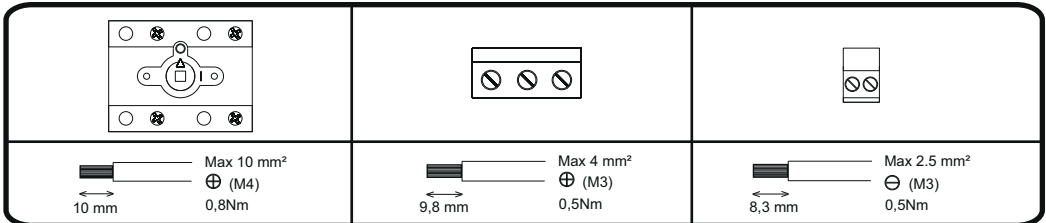
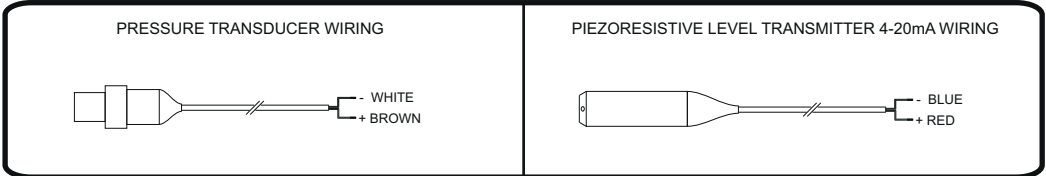
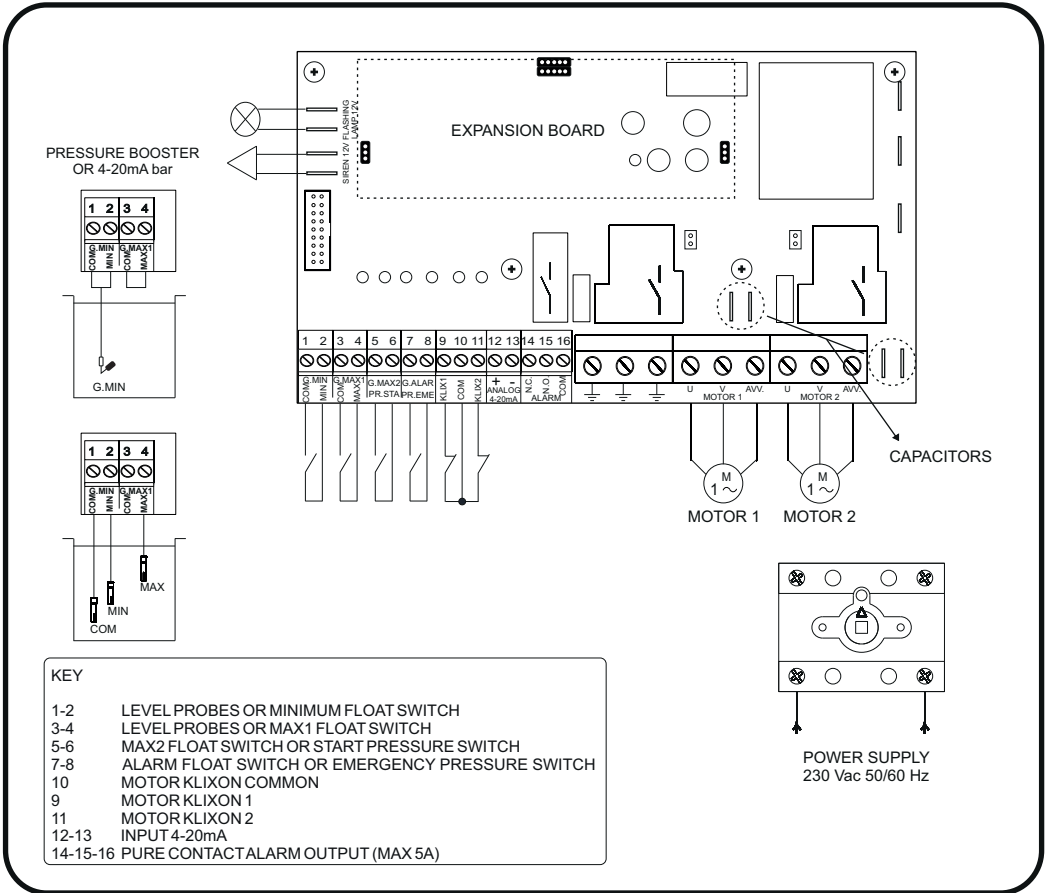

## 4. WIRING DIAGRAMS

### 4.2 Wiring diagram SA697.xx

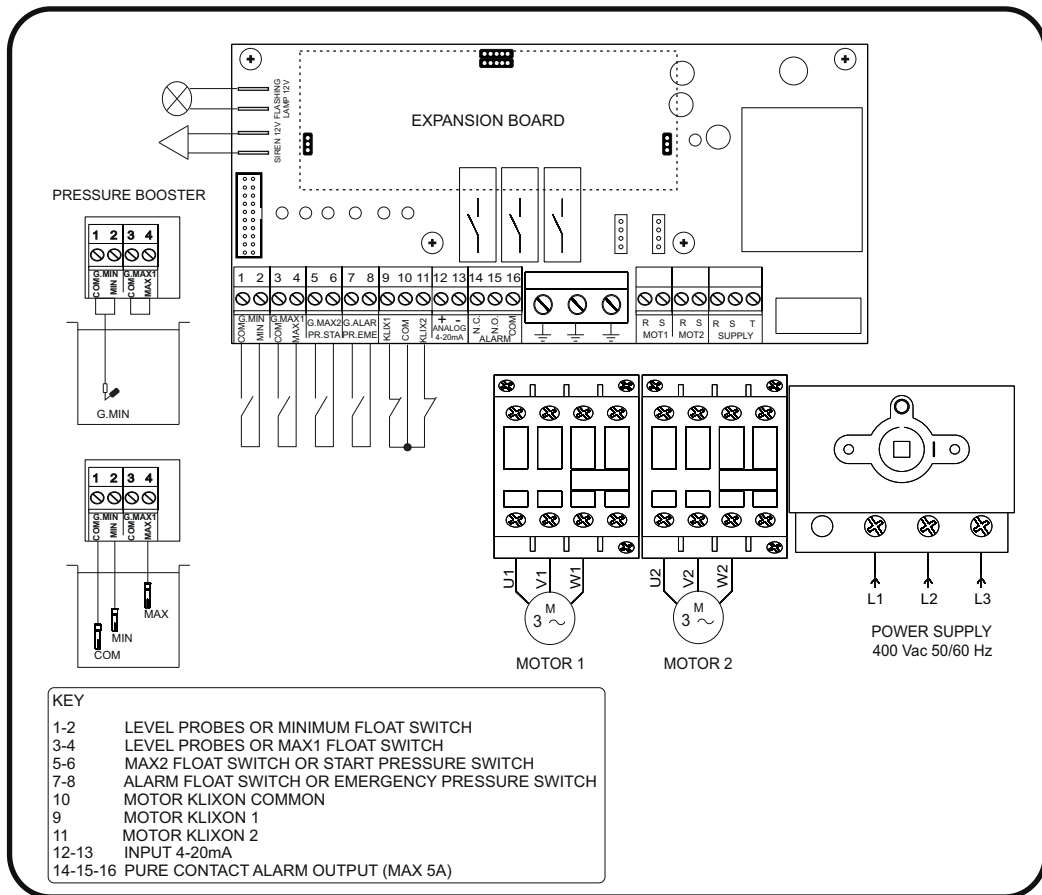

PRESSURE TRANSDUCER WIRING

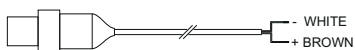

PIEZORESISTIVE LEVEL TRANSMITTER 4-20mA WIRING

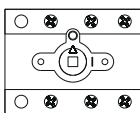

Max 10 mm<sup>2</sup>  
⊕ (M4)  
0,8Nm  
10 mm

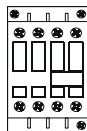

Max 6 mm<sup>2</sup>  
⊕ (M4)  
2,5Nm  
10 mm



Max 2.5 mm<sup>2</sup>  
⊖ (M3)  
0,5Nm  
8,3 mm

### 5.1 Fast programming ☆

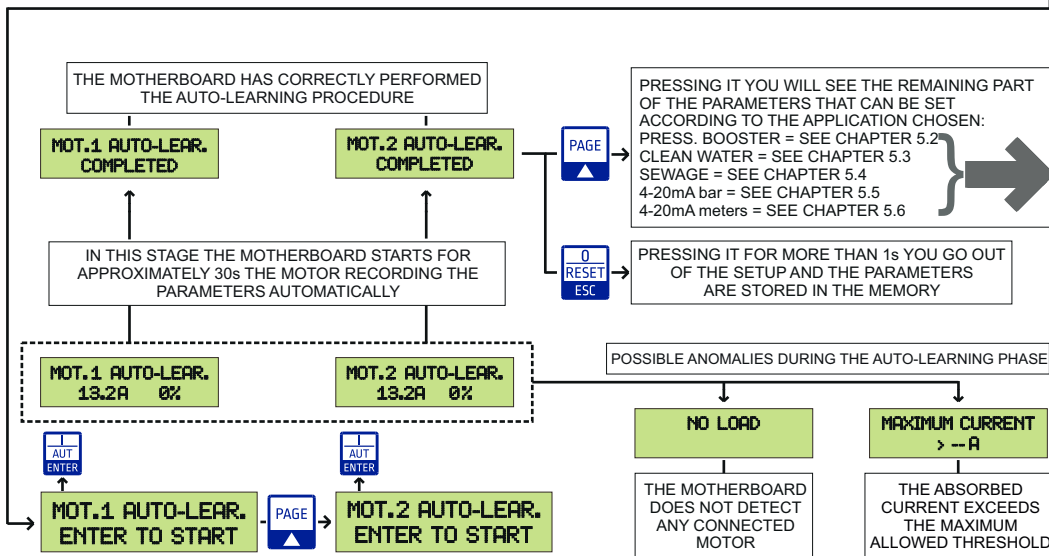
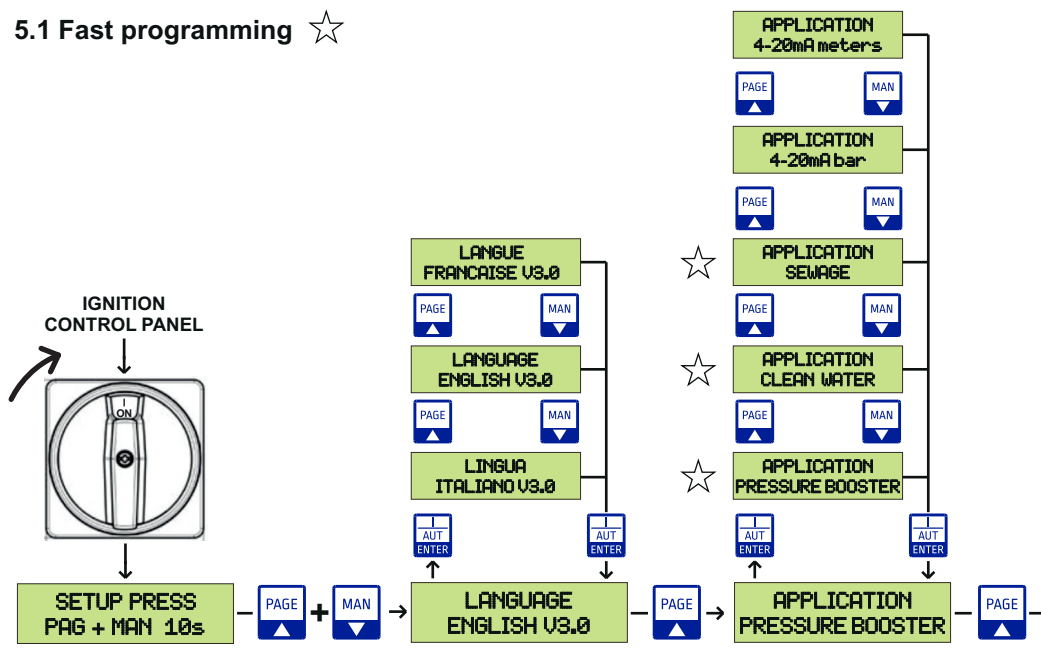

	Pressed it exits the parameter		Pressed it allows to enter the selected parameter Pressed confirms the set value
	It is used to scroll forward through the setup pages It is used to increase the value of a parameter		It is used to scroll back through the setup pages It is used to reduce the value of a parameter

## 5. PROGRAMMING

### 5.2 Application pressure booster

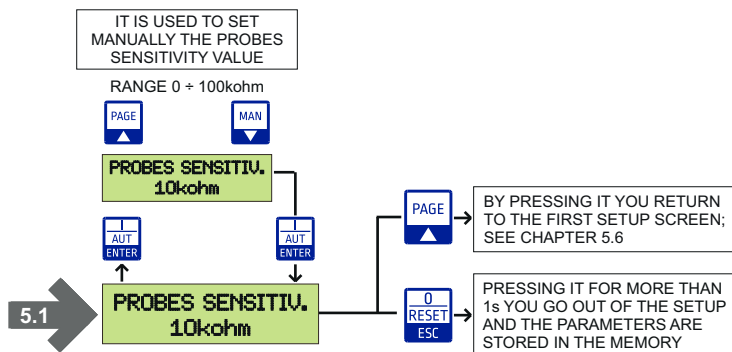

### 5.3 Application sewage

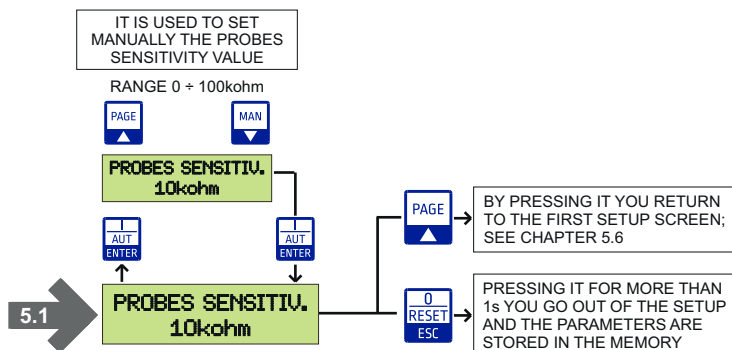

5.2 Application 4-20mA bar

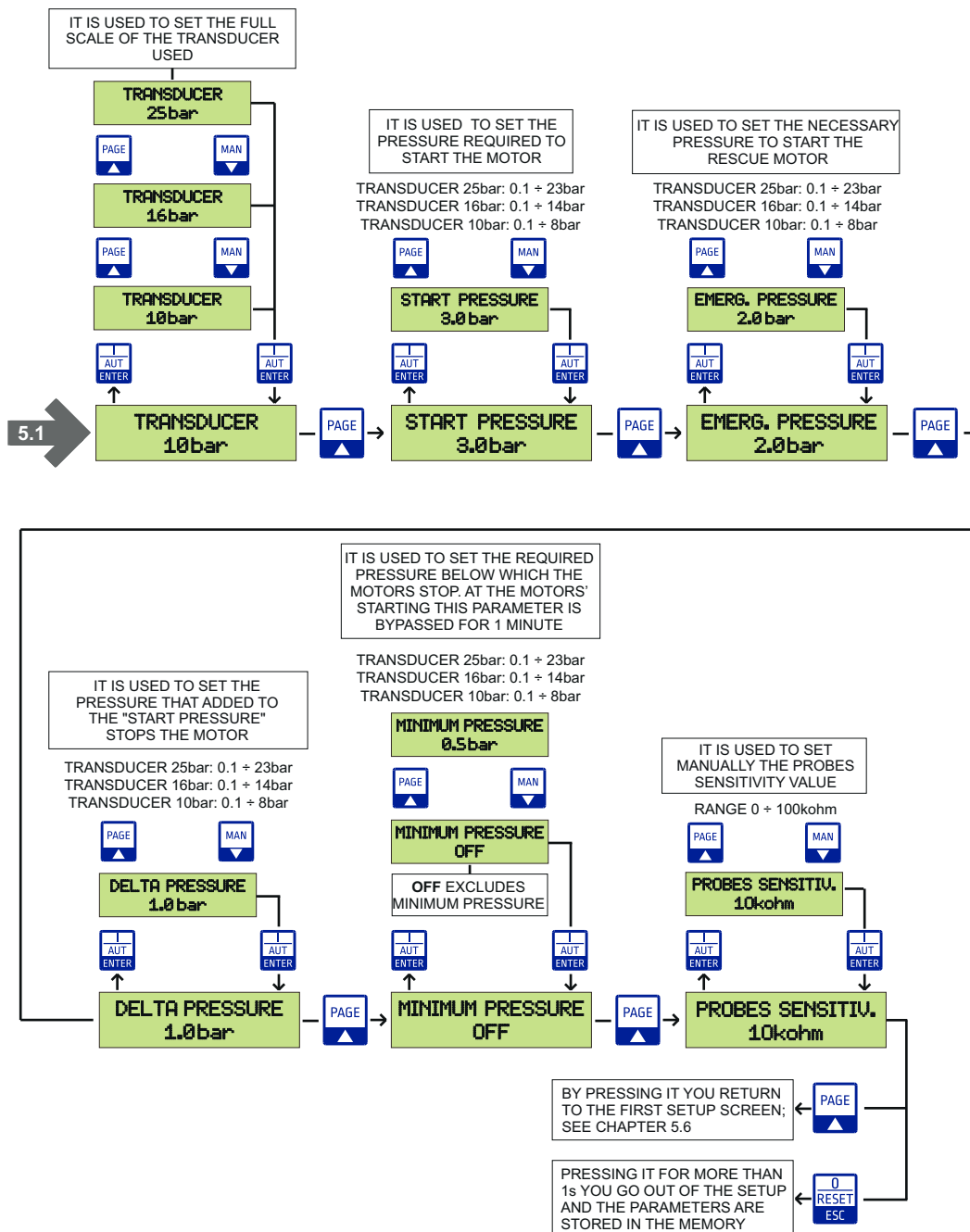

## 5. PROGRAMMING

### 5.3 Application 4-20mA meters

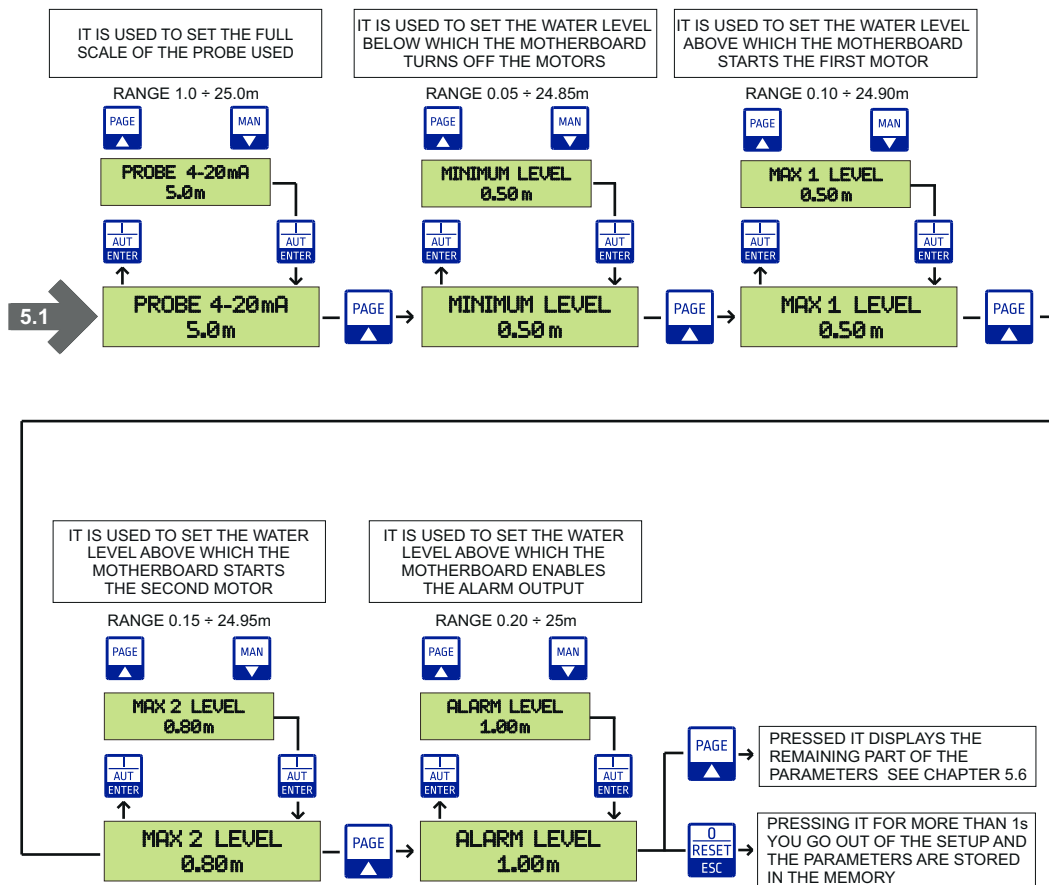

### 5.4 Advanced programming

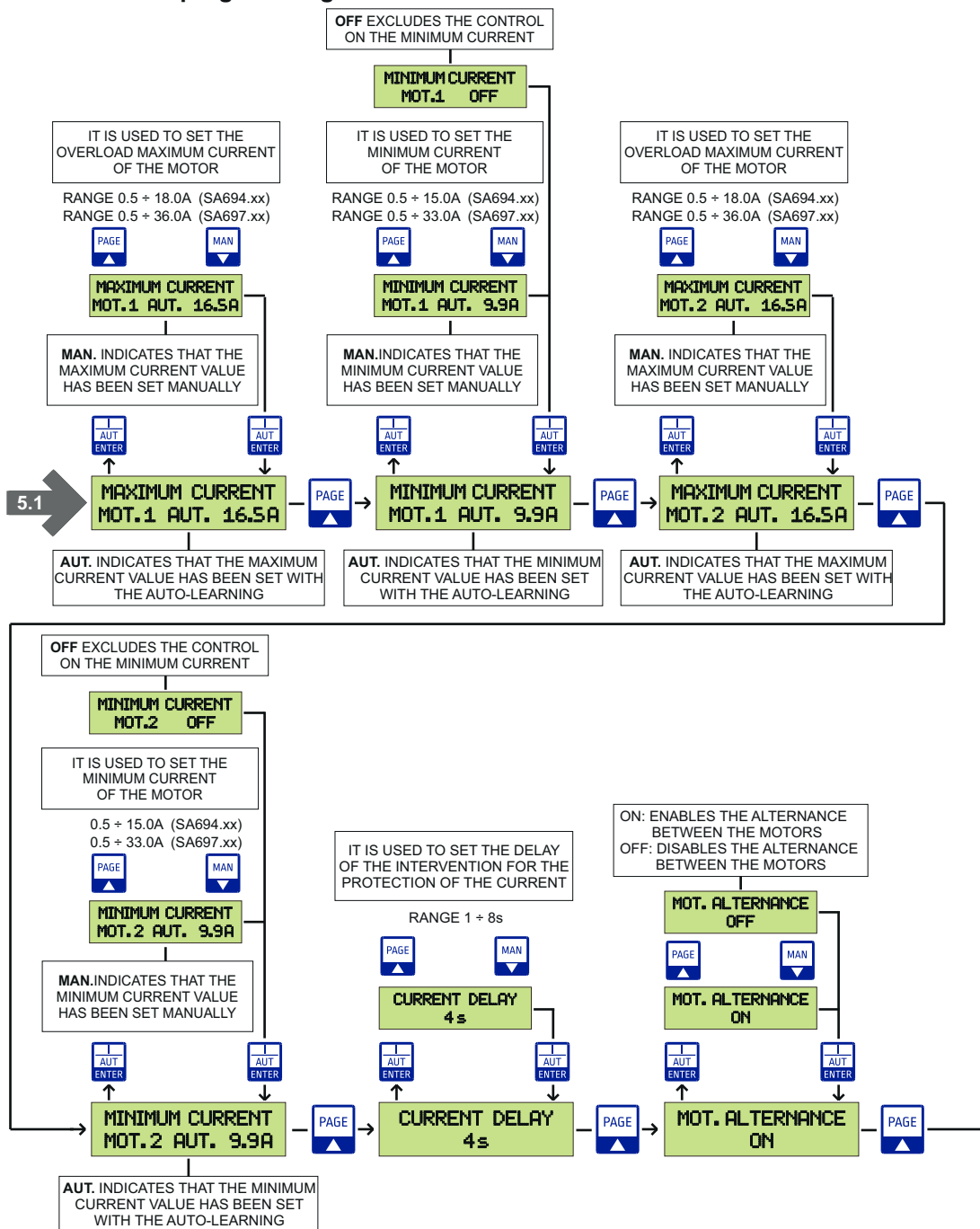

## 5. PROGRAMMING

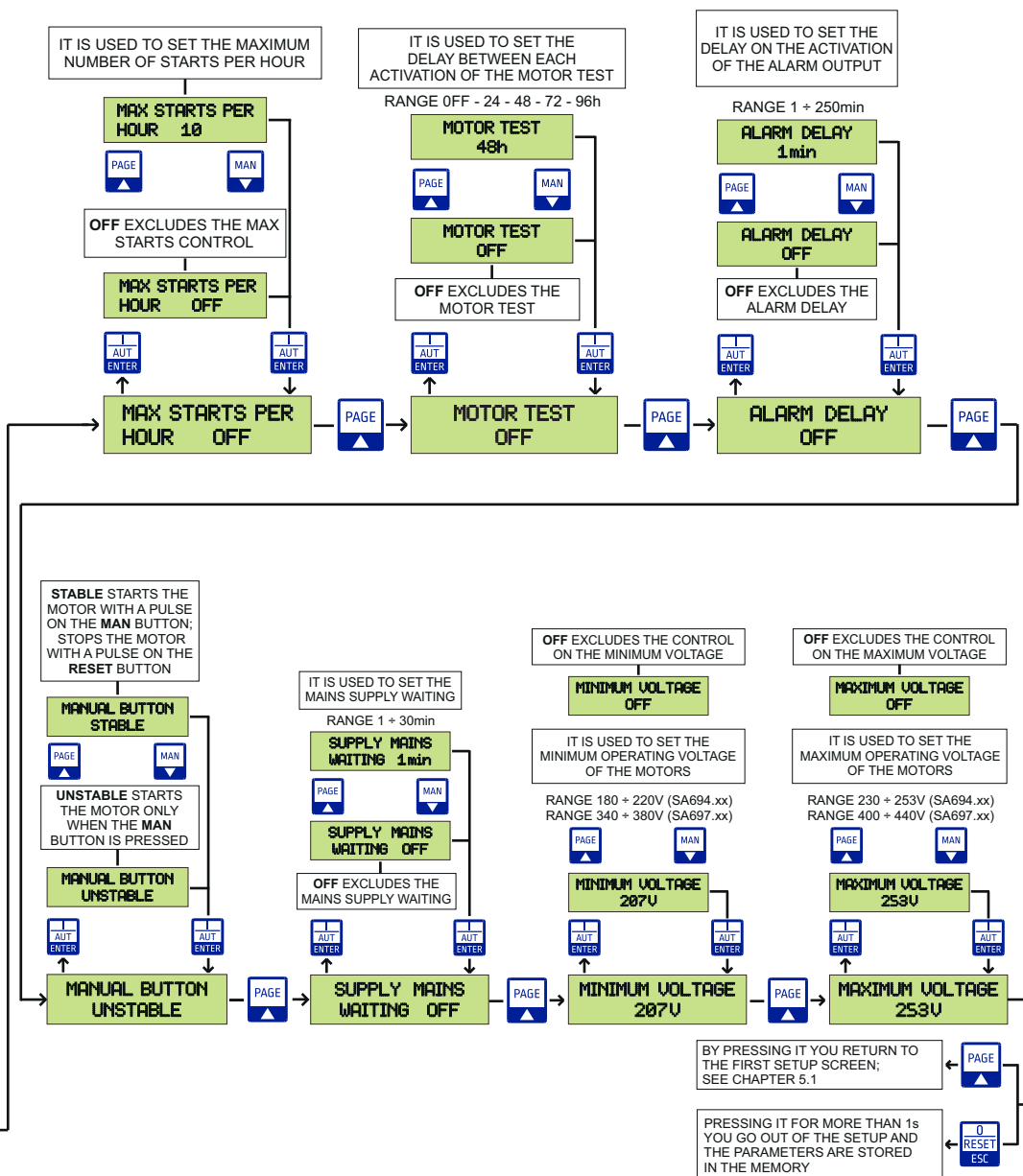

### 6.1 General functioning

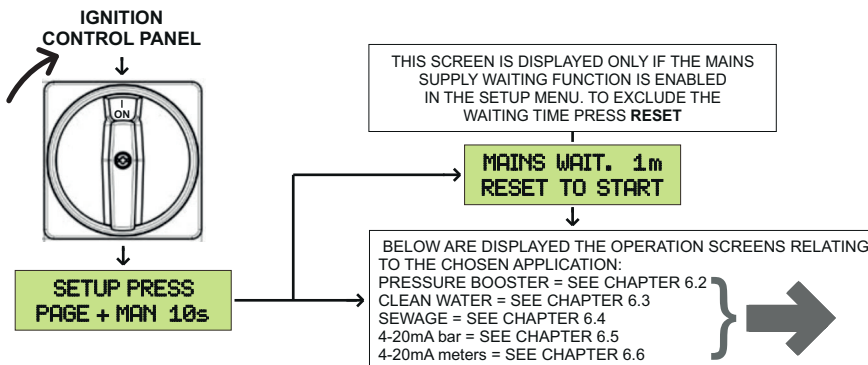

### 6.2 Application pressure booster

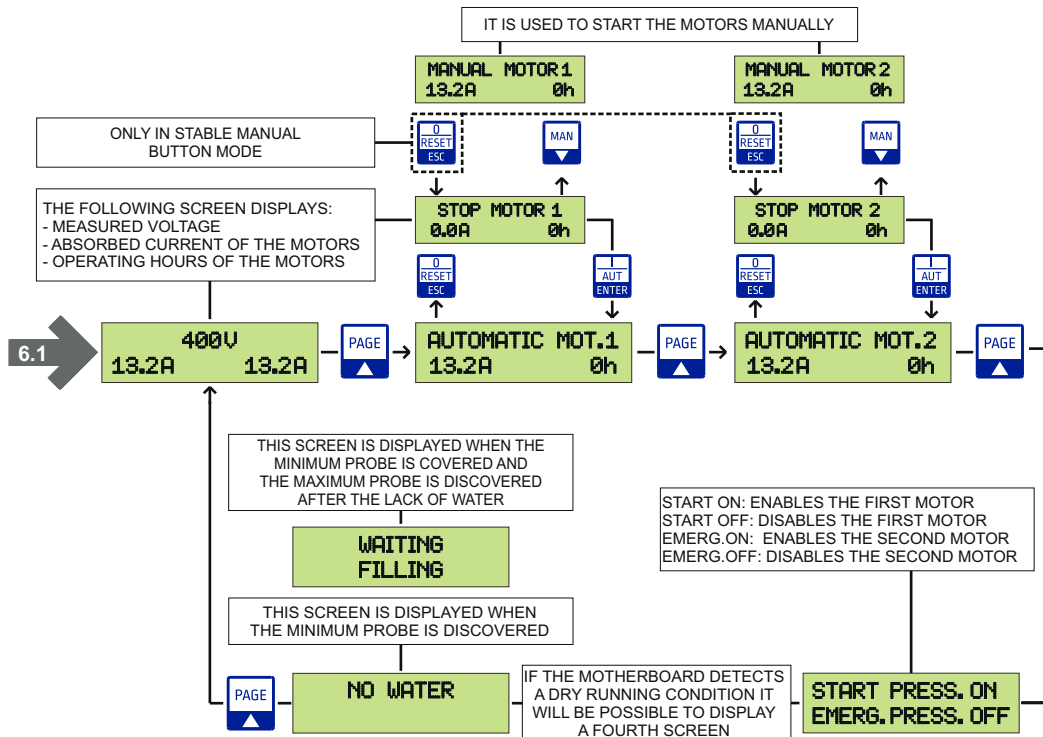

	Pressed the motor goes in STOP function Pressed in case of an alarm it resets it		Pressed it starts the motor in automatic mode
	It is used to scroll through the pages		Pressed in MOTOR STOP status it starts the motor in manual mode

## 6. GENERAL FUNCTIONING OF THE CONTROL PANEL

### 6.3 Application clean water

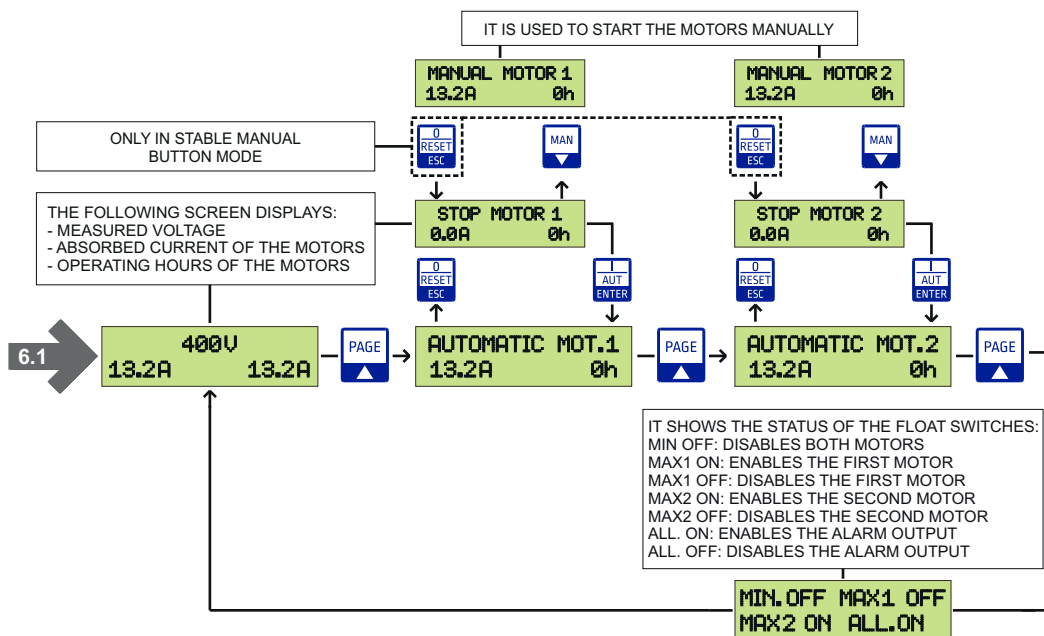

### 6.4 Application sewage

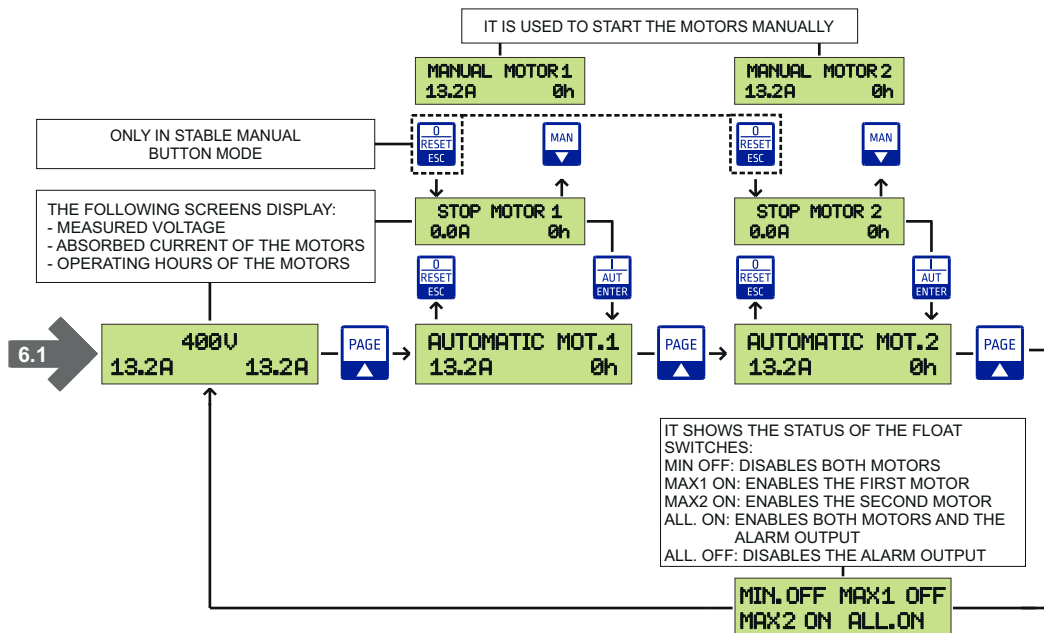

6.5 Application 4-20mA bar

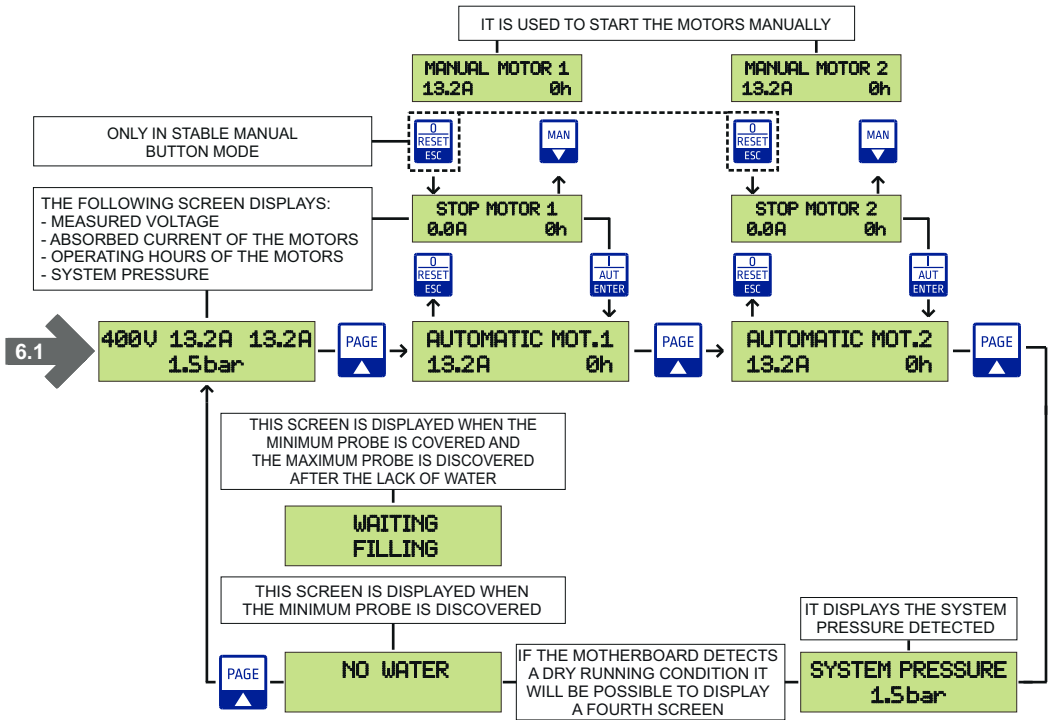

6.6 Application 4-20mA meters

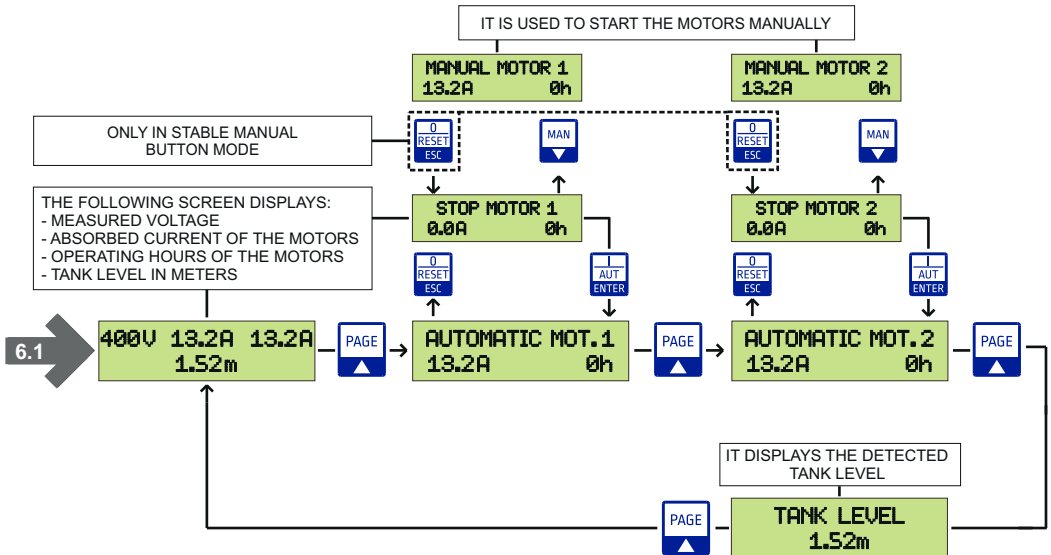

## 7. MOTORS MAINTENANCE

### 7.1 Motors maintenance programming

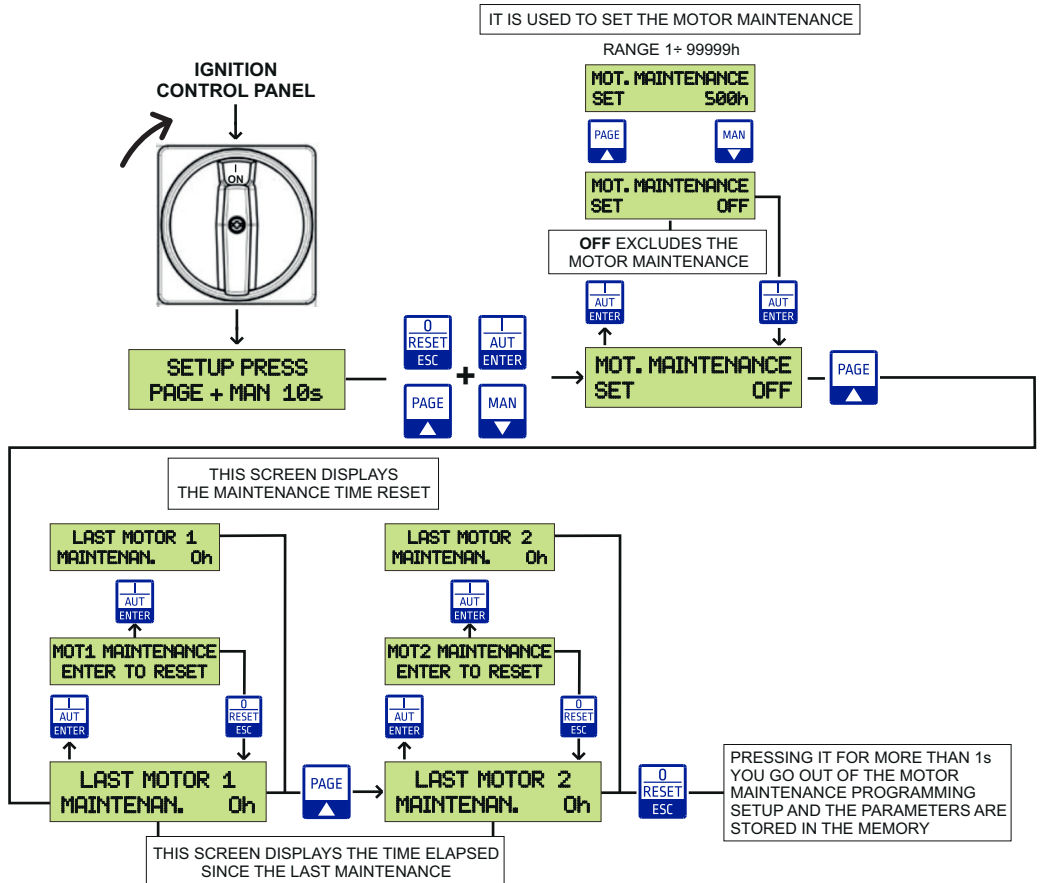

### 7.2 Motors maintenance messages

SCREEN	DESCRIPTION
PERFORM MAINTEN. ON MOTOR 1	Exceeded the set time, this screen will be displayed during operation, indicating to perform the motor 1 maintenance
PERFORM MAINTEN. ON MOTOR 2	Exceeded the set time, this screen will be displayed during operation, indicating to perform the motor 2 maintenance
PERFORM MAINTEN. ON MOTORS 1-2	Exceeded the set time, this screen will be displayed during operation, indicating to perform the both motors maintenance

### 8.1 Alarm data logger

The alarm data logger is used to display the last 20 stored alarms in descending order. The motherboard together with the alarm also records the motor operating hours in which it was generated.

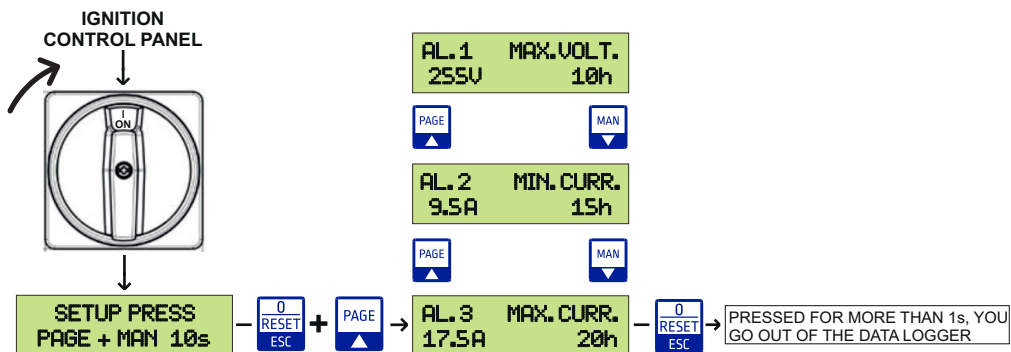

### 8.2 Event data logger

The event data logger is used to display the last 20 changes made in the setup relating to the motors protections in descending order:

- Minimum voltage
- Maximum voltage
- Minimum current for each motor
- Maximum current for each motor

The motherboard together with the event also records the motor operating hours in which it was generated.

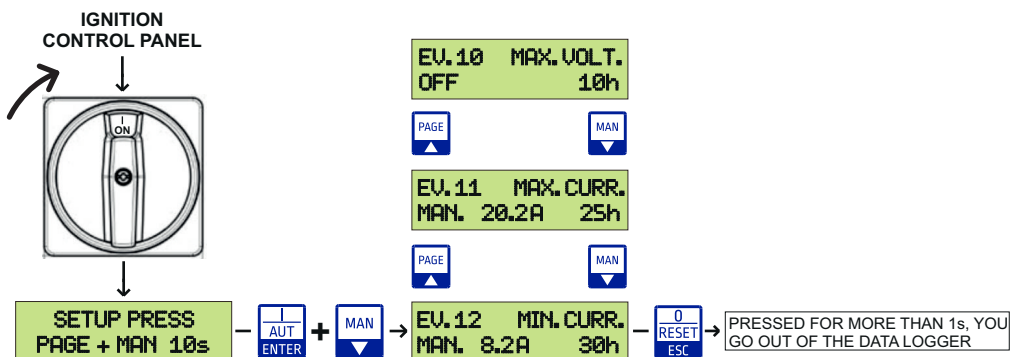

## 9. TROUBLESHOOTING AND PROPOSED SOLUTIONS

FREQUENT PROBLEMS	CAUSES	OPERATION
Display off	No supply	Feed the control panel respecting the input voltage
	Switch set on 0	Set the switch on 1
	The flat cable inside the control panel is not connected	Connect the flat cable from the motherboard to the display
MAXIMUM CURRENT motor 1 and 2 alarm	Maximum current set on the setup less than that absorbed by the motor	Set manually the maximum current the 25% more than the nominal value
	Motor blocked or damaged	Disconnect the motor and be sure it is working properly
Pressure BOOSTER application: PRESSURE SWITCHES OFF status with low pressure system	Possible failure of the pressure switches	Check the functionality of the pressure switches and of the cable and replace if necessary
Application SEWAGE/CLEAN WATER: FLOAT SWITCHES OFF with full tank	Possible failure of the float switches or connection cable interrupted	Check the functionality of the float switches and of the cable and replace if necessary
Application 4-20mA bar: Pressure value in bar displayed in the wrong display	Possible obstruction or failure of the 4-20mA pressure transducer	Clean carefully the pressure transducer or replace if necessary
Application 4-20mA meters: The displayed level in meter is wrong	Possible obstruction or failure of the piezoresistive probe 4-20mA	Clean carefully the piezoresistive probe or replace if necessary

DATA LOGGER	SCREEN	DESCRIPTION
✓	MAX. 1 CURRENT PRESS RESET	If the current absorbed by motors 1 or 2 exceeds the one set in the setup, the motherboard will turn off the motor and the display will show the following message.
✓	MIN. 2 CURRENT PRESS RESET	If the current absorbed by motors 1 or 2 is lower than the one set in the setup, the motherboard will turn off the motor and the display will show the following message.
✓	ALARM MINIMUM VOLTAGE	If the supply voltage drops below the minimum voltage and this condition persists for 5 seconds the alarm is activated, the motor is no longer powered and you will see the following message. If the voltage is within the set range and stays there for 60 seconds, the motherboard will automatically reset the alarm.
✓	ALARM MAXIMUM VOLTAGE	If the supply voltage exceeds the maximum voltage and this condition persists for 0.5 seconds the alarm is activated, the motor is no longer powered and you will see the following message. If the voltage is within the set range and stays there for 60 seconds, the motherboard will automatically reset the alarm.
✓	ALARM LACK OF PHASE	If the motherboard detects the absence of one of the three phases R, S, or T, (SA697.xx), the display will show the following message.
✓	ALARM REV. RST PHASES	If the sense of the cycle of the input voltages R, S, o, T (SA697.xx) is inverted, the display will show the following message.
✓	MAX STARTS MOT.1 PRESS RESET	If the number of starts per hour surpasses the preset limit (for motor 1 or 2), the motherboard will stop the motor and the display will show the following screen.
✓	KLIXON MOTOR 1	If the internal temperature of motors 1 or 2 exceeds the KLIXON thermal threshold, the motherboard will turn off the motor and the display will show the following message.
	MAXIMUM LEVEL ALARM 1.50m	If the water level in the tank exceeds the level set in the ALARM LEVEL parameter, the display will show the following screen.
	MINIMUM PRESSURE PRESS RESET	If the pressure in the system falls below the value set in the MINIMUM PRESSURE parameter of the setup, the motherboard will turn off the motor and the display will show the following message.

All alarms are automatically reset except for the maximum current and maximum starts per hour which are reset by pressing the  button for 2 seconds.

In the motherboard, when any type of alarm is generated, three outputs are activated, two 12Vdc outputs respectively for siren and flashing lamp and one with pure contact relay.

By means of the  button it is possible to silence the siren output which will remain deactivated until a new alarm is generated.

## 11. SMALTIMENTO DI VECCHI APPARECCHI ELETTRICI ED ELETTRONICI DISPOSAL OF ELECTRICAL & ELECTRONIC EQUIPMENT

 Questo simbolo sul prodotto o sul suo imballo indica che esso non può essere trattato come rifiuto domestico. Al contrario, dovrà essere portato ad un punto di raccolta determinato per il riciclaggio degli apparecchi elettrici ed elettronici, come ad esempio:

- punti vendita, nel caso si acquisti un prodotto nuovo simile a quello da smaltire
- punti di raccolta locali (centri di raccolta rifiuti, centri locali di riciclaggio, ecc...).

AssicurandoVi che il prodotto sia smaltito correttamente, aiuterete a prevenire potenziali conseguenze negative per l'ambiente e la salute, che potrebbero essere causate da un inadeguato smaltimento di questo prodotto. Il riciclaggio dei materiali aiuterà a conservare le risorse naturali. Per informazioni più dettagliate riguardo il riciclaggio di questo prodotto, contattate per cortesia il Vs. ufficio locale, il Vs. servizio di smaltimento rifiuti domestici o il negozio dove avete acquistato questo prodotto.

 This symbol on the product or its packaging indicates that it shall not be treated as household waste. Instead, it shall be handed over to the applicable collection point for the recycling of electrical and electronic equipment, such as for example:

- sales points, in case you buy a new and similar product
- local collection points (waste collection centre, local recycling center etc...).

By ensuring this product is disposed of correctly, you will help prevent potential negative consequence for the environment and human health, which could otherwise be caused by inappropriate waste handling of this product. The recycling of materials will help to preserve natural resources. For more detailed information about recycling of this product, please contact your local city office, your house hold waste disposal service or the shop where you purchased the product.

## 12. DICHIARAZIONE DI CONFORMITA' DECLARATION OF CONFORMITY



**Fabbricante / Manufacturer**

**SALUPO S.r.l.**

C/da Pietra di Roma – Via Vicolo VI, n° 2  
98070 Torrenova [ME] ITALY

Dichiara sotto la propria responsabilità che i prodotti:  
*Declares under own responsibility that the product:*

**Modelli / Model**

MULTIPLUS 2

**Codici / Code**

SA694-697.xx

Sono conformi alle seguenti norme/ *They comply with the following standards:*

BS EN 61439-1:2012-02	Low-voltage switchgear and controlgear assemblies
BS EN 61000-6-3:2007+A1:2011	Electromagnetic compatibility [EMC]
BS EN IEC 61000-6-1:2019-06	Electromagnetic compatibility [EMC]
BS EN 60204-1:2018 [IEC 204-1]	Safety of machinery. Electrical equipment of machines

Torrenova 02/11/2022

**SALUPO S.r.l.**  
Technical Dep. Manager  
Salupo Ivan

## 13. CERTIFICATO DI GARANZIA WARRANTY CERTIFICATE

Gentile Cliente,

La Salupo S.r.l. desidera ringraziarLa per la preferenza accordata. Il prodotto da Lei acquistato è coperto da garanzia come di seguito illustrato. Garantiamo la qualità e il buon funzionamento dei nostri prodotti fino a 24 mesi, a partire dalla data di acquisto, contro difetti di fabbricazione e di realizzazione eccetto per i seguenti quadri per i quali garantiamo 12 mesi: **SQ702.xx; SQ712.xx; SQ722.xx; SQ687.xx/SS; SQ697.xx/SS; SQ696.xx/SS**. La Salupo S.r.l. si assume l'impegno di riparare o di sostituire gratuitamente il vostro prodotto nel caso in cui ricorrano le presenti condizioni:

1. I prodotti resi nell'ambito della garanzia devono essere accompagnati dalla descrizione del difetto riscontrato, dalla prova dell'acquisto del prodotto (fattura) e dai dettagli di contatto: nominativo, numero di telefono, indirizzo completo – via o piazza, codice di avviamento postale, città e provincia.
2. I prodotti restituiti alla Salupo S.r.l. devono essere imballati in modo adeguato. La Salupo S.r.l. declina ogni responsabilità per i prodotti perduti o danneggiati durante il trasporto dal cliente.
3. L'utilizzo dei prodotti deve avvenire in piena conformità con le istruzioni operative fornite nella confezione. La Salupo S.r.l. declina ogni responsabilità per danni cagionati da caduta, uso scorretto, alterazione o negligenza.
4. Questa garanzia non incide sui diritti del consumatore sanciti dalla normativa vigente.

**Salupo S.r.l.**

*Dear customer,*

*Salupo S.r.l. would like to thank you for your preference. The product you have purchased is covered by the warranty as shown below. We guarantee the quality and smooth operation of our products up to 24 months, starting from the date of purchase, against manufacturing defects and except for the following items for which we guarantee up to 12 months: **SQ702.xx; SQ712.xx; SQ722.xx; SQ687.xx/SS; SQ697.xx/SS; SQ696.xx/SS**. Salupo S.r.l. undertakes to repair or replace your product free of charge in the event that these conditions are met:*

- 1. The products returned as part of the warranty must be accompanied by the description of the defect found, the proof of purchase of the product (invoice) and contact details: name, telephone number, complete address - street or square, postal code, city and province.*
- 2. The products returned to Salupo S.r.l. must be packaged appropriately. Salupo S.r.l. declines all responsibility for products lost or damaged during transport by the customer.*
- 3. The use of the products must be in full compliance with the operating instructions provided in the package. Salupo S.r.l. declines any responsibility for damages caused by fall, misuse, alteration or negligence.*
- 4. This guarantee does not affect the rights of the consumer as set out in current legislation.*

**Salupo S.r.l.**



**0508 4 BBENG**  
**[www.brownbros.co.nz](http://www.brownbros.co.nz)**

