

CP Brochure

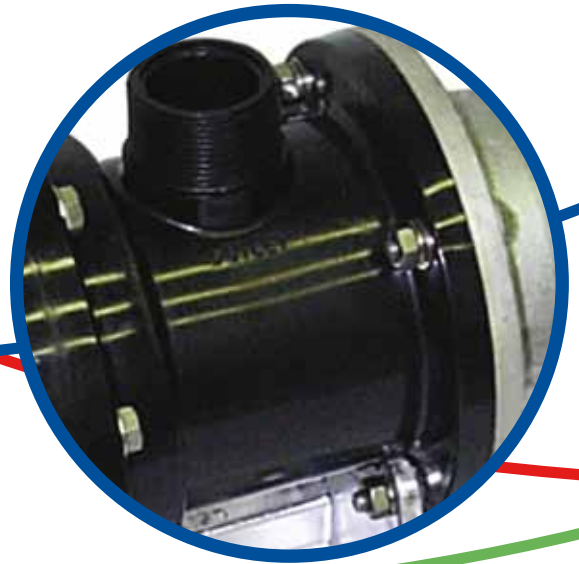

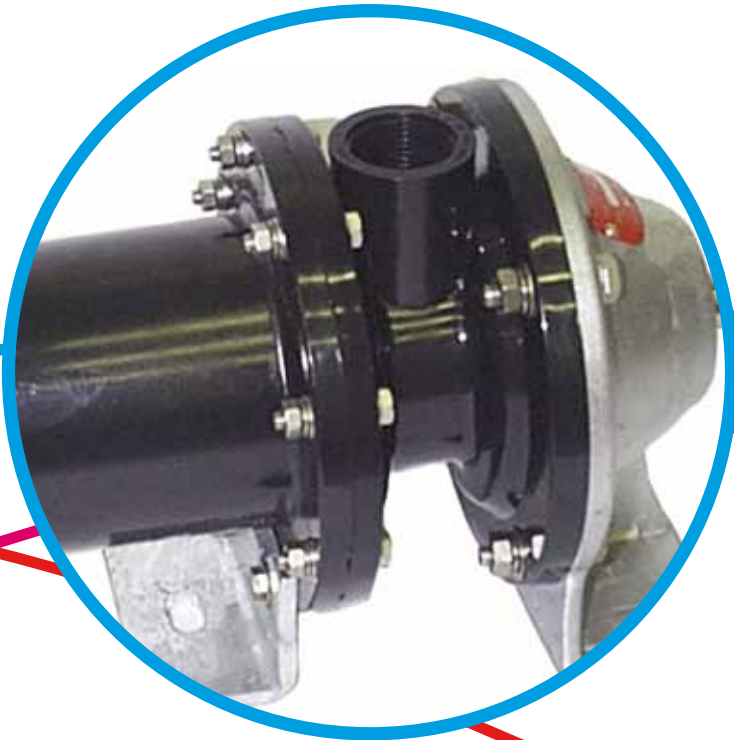
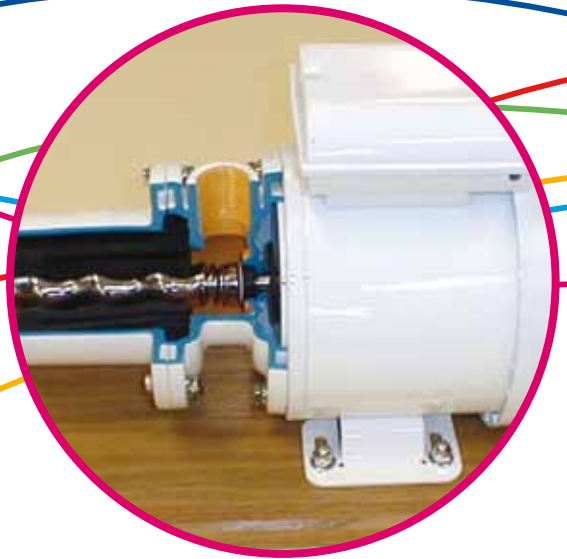

The Great Little All-Rounder:

NOV MONO® CP RANGE PUMPS:

Simple design. Sturdy lightweight construction. Conveniently compact.

Whether for domestic pumping requirements, or light industrial duties - they'll keep up with the pressure of work!

Four models available (CP11, CP25, CP800 and CP1600) each operating on the well proven "progressive cavity" principle, and between them a variety of performance capabilities, up to a maximum capacity of 1650 gph (125lpm), and pressures of up to 92 feet (28 metres).

STATOR OPTIONS:

- Natural.
- Nitrile (Standard).
- Hypalon.
- High Nitrile.
- Fluoroelastomer (CP11 and CP25 only).

THE NOV MONO® PRINCIPLE:

The CP uses the famous helical rotor pumping principle.

The heart of the Mono Pump is the single helix metal rotor which rotates eccentrically within a double helix resilient stator of twice the pitch length of the rotor. The rotor of circular cross section creates a continuously forming cavity as it rotates. The cavity progresses towards the discharge end, advancing in front of a continuously forming seal line, carrying the pumped material with it. As the stator open cross sectional area is always constant the flow rate is continuous without pulsation.

THE PRINCIPLE BENEFITS ARE:

1. Capacity is proportional to speed.
2. Self priming even with entrained air.
3. Can handle a variety viscous materials.
4. Minimal damage to shear sensitive products.
5. Can handle liquids containing solids or abrasive particles.
6. Pulsation free operation.
7. Positive displacement.

Bareshaft & Motorised:

CP11 & CP25 Bareshaft

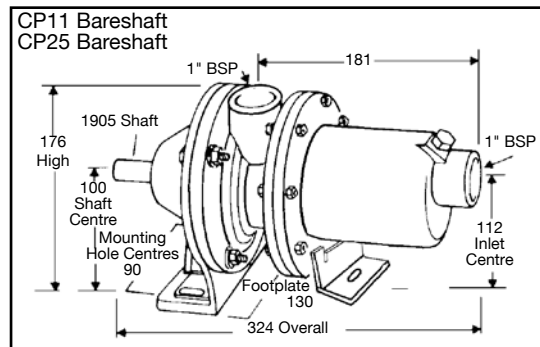

CP800 & CP1600 Bareshaft

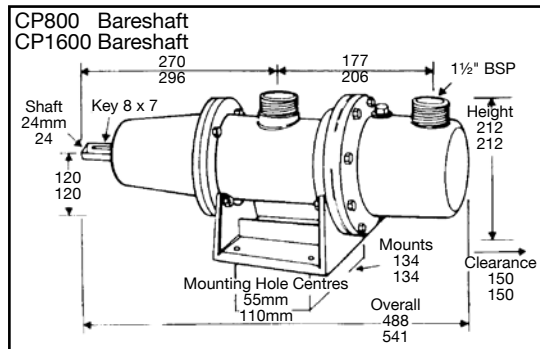

CP11 & CP25 Motorised

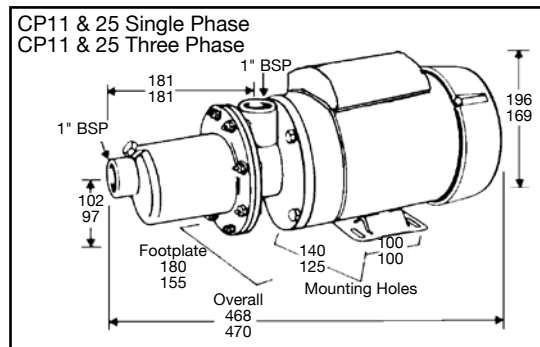

CP800 & CP1600 Motorised

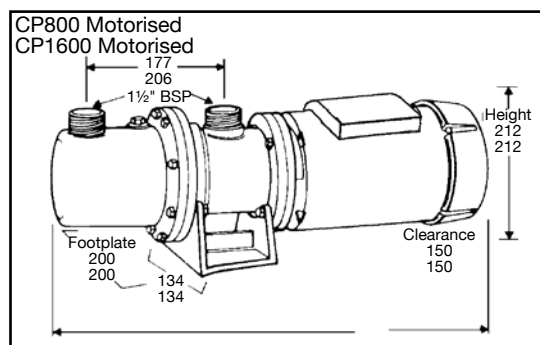



Pre-selection Information

FEATURES & BENEFITS:

Single mechanical seal	Low maintenance
Self priming up to 6 m	High suction lifts
Tough engineered grade acetal co-polymer plastic housing	Long lasting, low replacement costs
Stainless steel internal rotating parts	Corrosion free, long life
Close coupled drive arrangement	Compact in size
Simple and easy to maintain	Low maintenance
Integral mounting bracket	Ease of installation
Tropical proof motor as standard	Can be installed outside
BSP threaded port connections	Ease of installation
Stainless Steel fasteners	Long Life
Bareshaft options	Optional drive selections

PERFORMANCE TABLE:

Flows to:	CP11	11 lpm
	CP25	25 lpm
	CP800	60 lpm
	CP1600	125 lpm
Heads to:	28 metres	
Motor options:	240v and 415v	
Maximum speed:	1450 rpm	
Lead length:	2 metres (240v only)	

SUCTION CURVES:

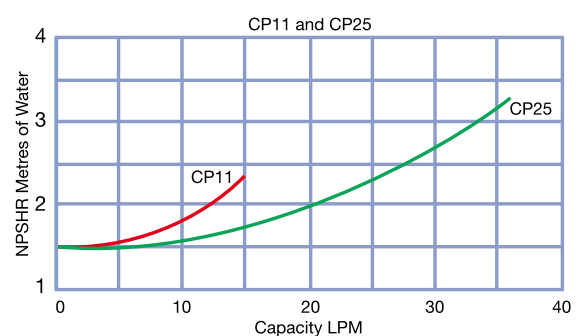
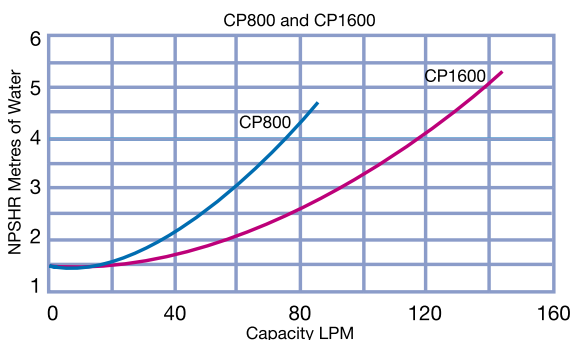

* For pressures above 28 metres contact Mono Pumps Technical Support on 1800 333 138.

Typical products/applications:

- Milk
- Honey
- Food colour
- Fruit juice
- Wine
- Detergents
- Mustard
- Domestic Water Supply
- Septic Effluent
- Brine injection for meat curing
- Oily water
- Molasses transfer stock feed



MOLASSES FEED PUMP UNIT



SHALLOW BORES



TROLLEY UNIT WINE TRANSFER



OILY WATER SEPARATOR



Member of AxFlow Group

0508 4 BBENG
www.brownbros.co.nz

www.monopumps.com.au



© Mono Pumps Limited May 2011 Literature reference: ART01-7
Published information other than that marked CERTIFIED does not extend any warranty or representation, expressed or implied, regarding these products. Any such warranties or other terms and conditions of sales and products shall be in accordance with Mono Pumps Limited standard terms and conditions of sale, available on request.
Mono® is a registered trademark of Mono Pumps Ltd.
Registered in England No 300721



One Company, Unlimited Solutions