

Series A Muncher



A high torque, low speed grinder for open channel and wet well installations suitable for the efficient disintegration of solids within a flow.

Typical Applications

- Pump protection for sewage or sludge pumping
- Screenings maceration
- Headworks maceration
- Industrial effluent conditioning
- Bio-degradable waste maceration for recycling processing
- Submersible pump protection

Capacity

- Up to 5,315 gal/min

Features and Benefits

Capacity Slow Operational Speeds

Lower cutter tip speeds dramatically reduce wear rates. The downtime for cutter replacement is reduced resulting in lower maintenance costs. Slow speeds also ensure low noise and vibration.

Flexible Design

Munchers can be configured for channel, wet well, and pipeline installations. Multiple drive options are available including hydraulic or submersible motors.

Lower Power Consumption

Cost savings especially when compared to high speed macerators.

Simple Construction

- Minimal attention and maintenance
- Ease of servicing - no special tools or fitting skills required
- Reduction in downtime

Built-in Overload Protection

Prevents serious damage to the Muncher, saving on costly downtime.

Standardization

Interchangeability of components. One set of spares required for all machines. Reduced level of parts inventory. Dimensionally compatible with competitive manufacturers.

Individual Cutting Elements

Cost reduction by having to replace only worn cutting elements.

Ease of Installation

No complex civil foundation work required – can be installed into existing channel.



Series A Muncher

Performance Data & Dimensions

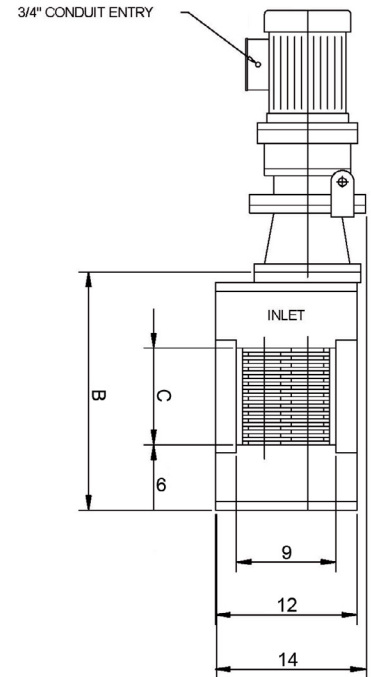
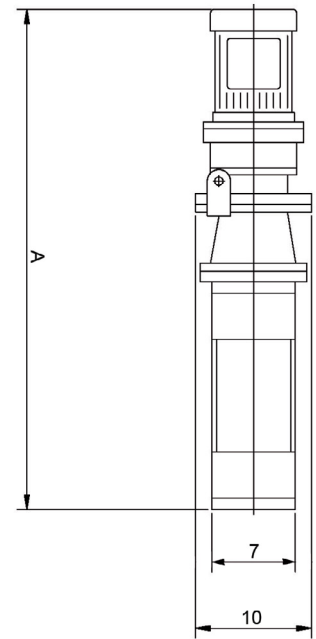
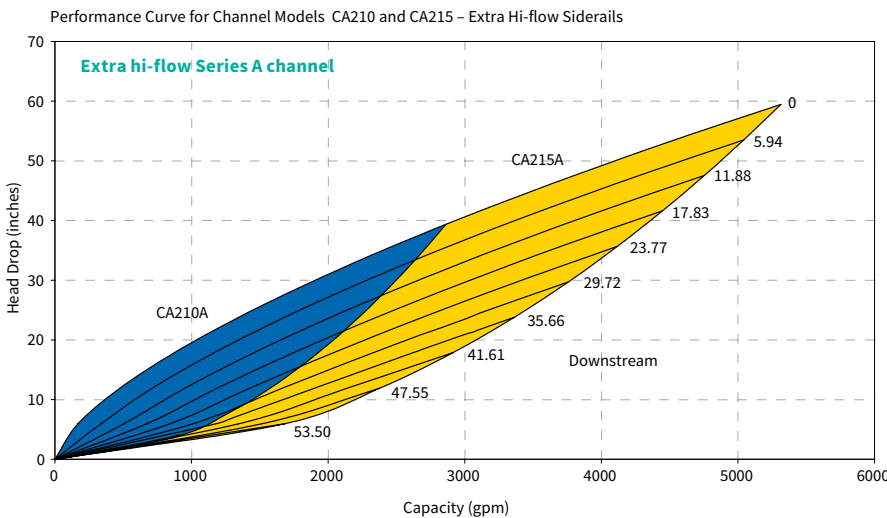
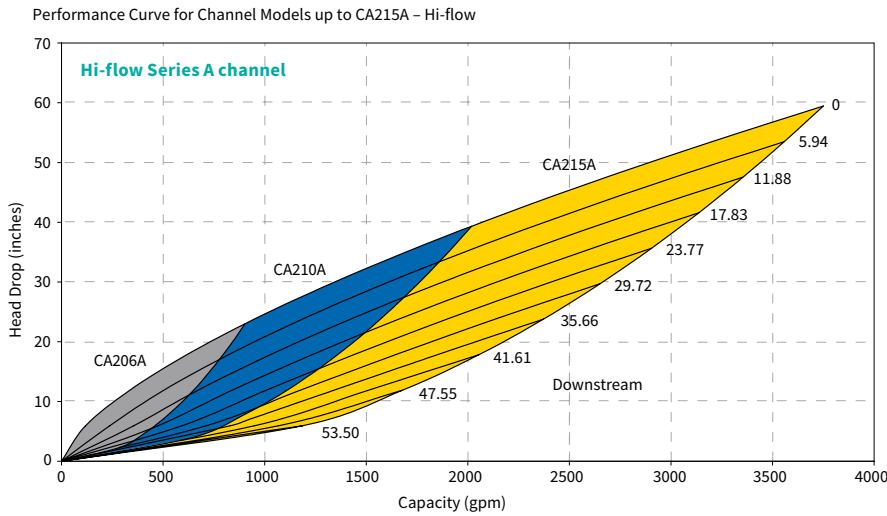
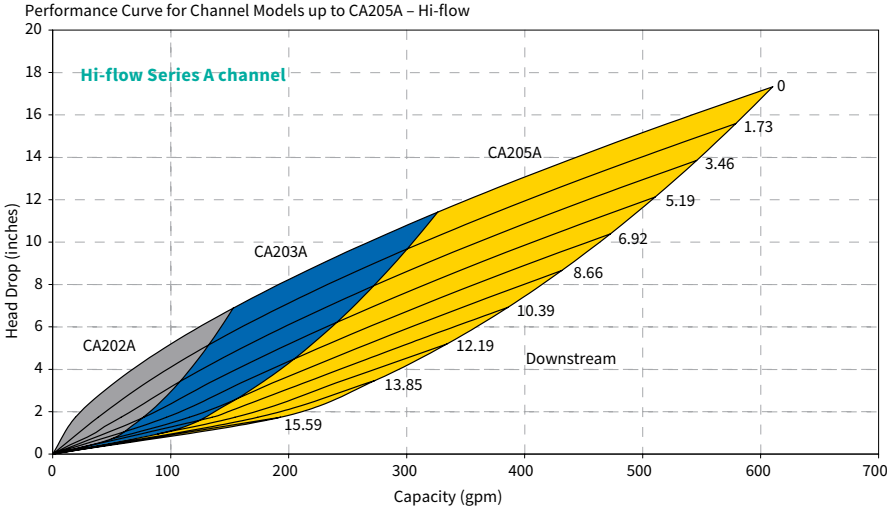

MODEL	A	B	C
A202	49.5	20.3	6.9
A203	54.0	24.8	11.4
A205	59.9	30.7	17.3
A206	65.6	36.4	23.0
A210	82.0	52.7	

All dimensions are in inches and for guidance only. For more information about the Series A Muncher, contact NOV.