

# Muncher™ Family

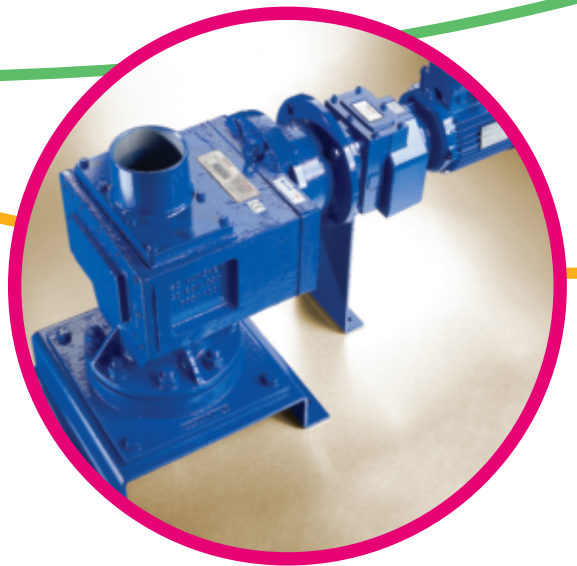
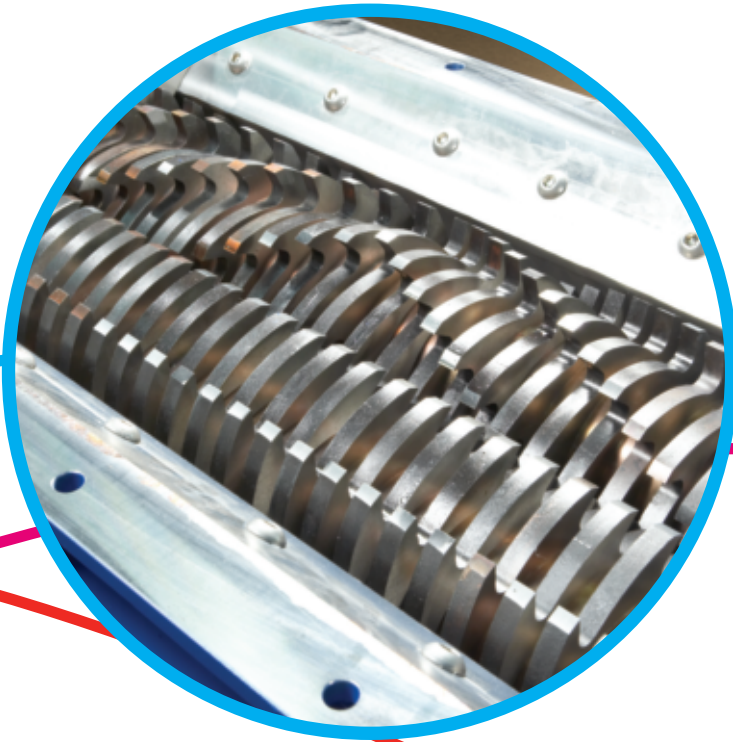

# Introduction

Time and time again The Muncher Family proves to be the most economical solution to a problem many of our customers previously thought impossible to solve.

- protection of submersible or dry well sewage pumps prone to blockage problems
- economical solution for small headworks requirements
- efficient disintegration of extracted screenings prior to treatment
- high volume fine grinding of sludges improving digestion plant efficiency
- handling of tankered sludges to a whole host of industrial wet waste grinding duties

The Muncher Family is designed to cope with modern waste waters and sludges, with all the discarded trappings of today's disposable society that find their way into community and industrial waste collection and treatment systems.

## The Principle

The Muncher Family is a range of Twin Shaft, Slow Speed, High Torque Grinders.

Each shaft is fitted with a series of interleaving cutters and spacers to give real "positive displacement" solids grinding. Once an object becomes trapped in the slowly revolving cutter stacks there is no escape - rags, rope, plastic, drink cans, panti-hose, wood and sundry rubbers are all easily processed through the machine.

Powerful it may be - energy wasteful it is not!

- Shafts operate at differential speeds - to promote a tearing action on the solids
- Low operating speed (typically 50-80 rpm) give high torque capability
- Low cutter tip speeds ensure power is not wasted in "water horsepower" and abrasive wear rates are minimised
- Various Unique Patented Items

## Optimum Grinding Capability

The differential speed of the cutter stacks pull apart fibrous material, whilst the leading edge and sides of the cutter teeth crop and shear plastic into small pieces. The circumferential 'land' of the cutter crushes friable or brittle material.

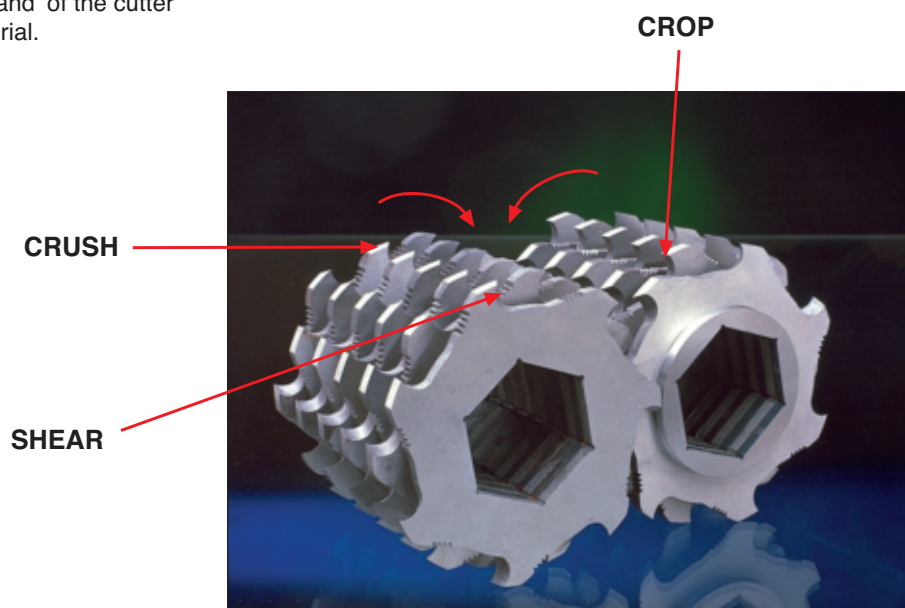

# Features - SB and TR Muncher

## SB Range

- Designed to replace traditional high speed, high power centrifugal macerators
- Low cutter tip speeds - Low power - Low noise level
- 3 Year warranty on Raw Sewage applications for pipeline units

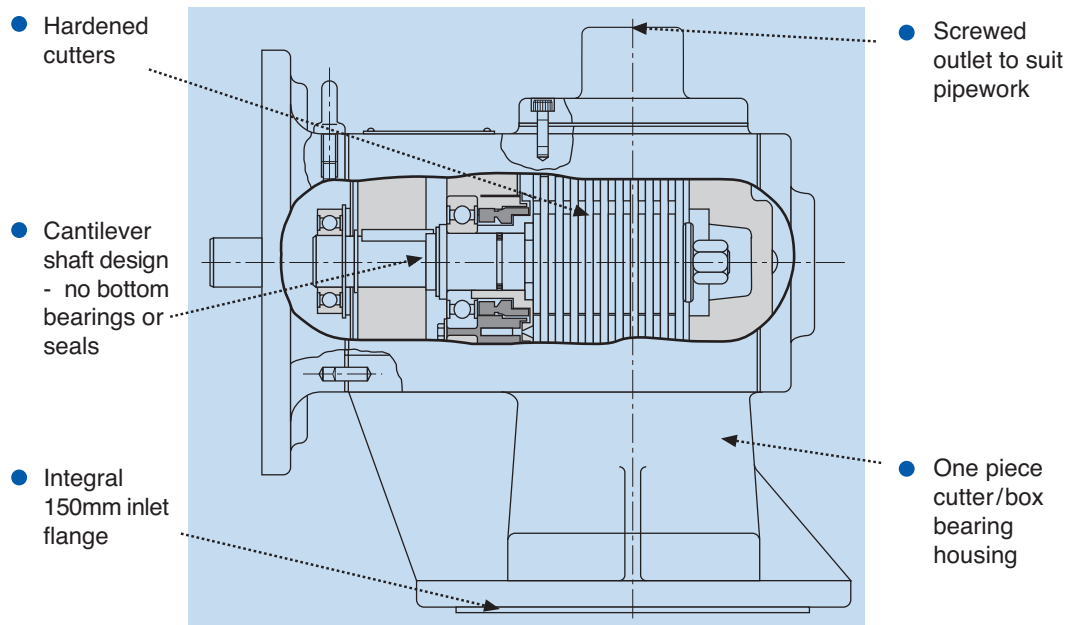

## TR Range

- Latest Generation Twin Shaft Grinder
- Designed specifically for efficient treatment of abrasive sludges

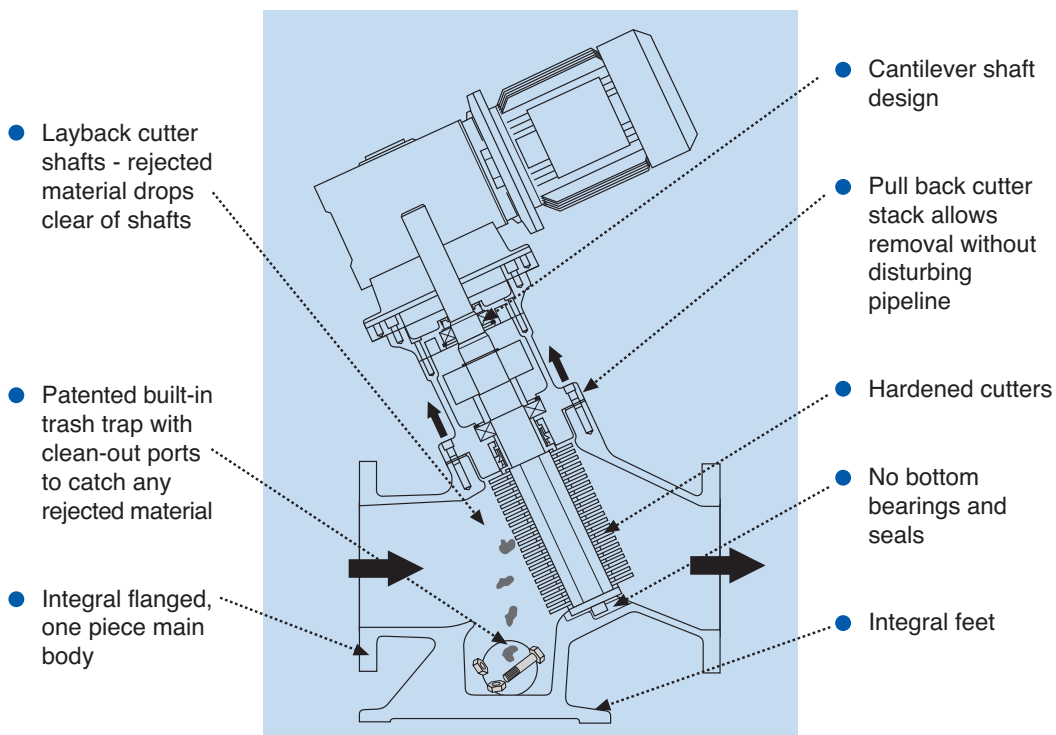

# Features - Series 'A' and F Muncher

## Series 'A' Range

- Engineered and improved through 35 years experience in waste water grinding

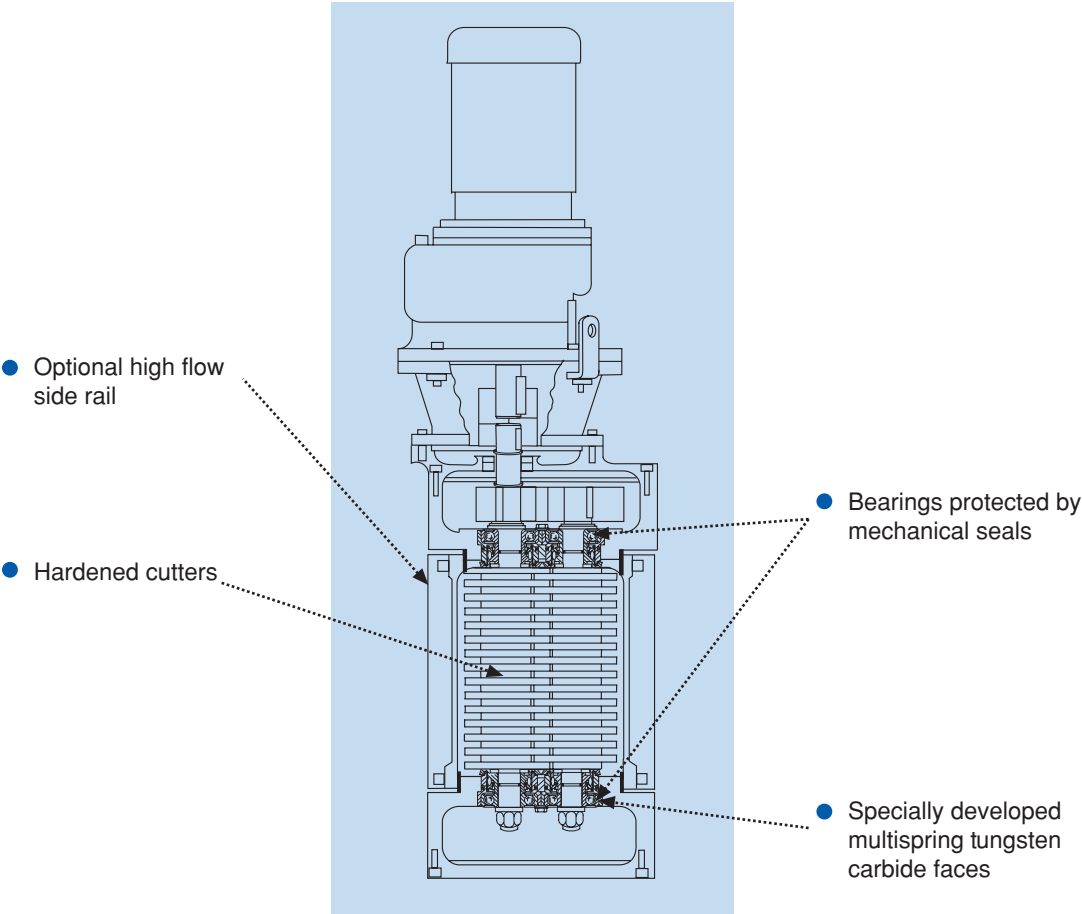

## Series F Range

- For wet and dry material processing
- Ideally suited for screenings/bio-degradable waste processing
- Eliminates need for costly disposal - can generate income from better digester gas yields

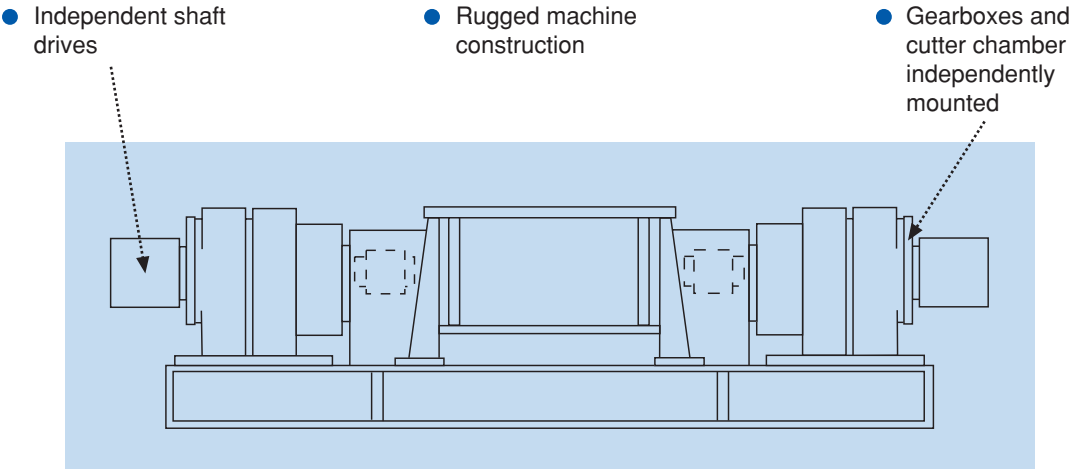

# Control Equipment

Each Muncher is supplied with a Programmable Logic Controller (PLC) designed to protect the machine against damage from rogue materials and overloads. This can be as an individual PLC unit, a chassis backplate, or a complete control panel.



The Muncher PLC is designed to distinguish between a locked rotor full overload requiring instant reversal and a varying allowable periodic low level overload allowing an ongoing running period before the reversal mode is engaged. The critical time/power relationship is continually monitored by the logic to avoid either unnecessary shutdowns or failure to respond to genuine overloads that less sophisticated systems could induce.

This logic control unit is programmed to operate in the following manner:

1. To operate in a normal On/Off mode.
2. To sense an overload condition (jam), momentarily reverse the cutters to clear the condition and then return to normal operation.
3. If a third overload (jam) occurs within 60 seconds of the first, the machine will then automatically shut down in reversed mode and an alarm circuit will be energised. (Alarm not supplied in standard packages).

Panel layouts are available to all UK Water Company standards, Sewers for Adoption and most international standards including I.E.C., N.E.M.A., and Australian.

Typical PLC Unit for assembly into composite systems



Typical Control Panel

## Standard Supply is:

- Series 'A' Muncher - Complete control panel to IP55
- SB Muncher - Controller optional
- TR Muncher - PLC Unit
- Series F Muncher - Complete control panel to IP55

# Applications - Pump Protection

## SB, TR & Series 'A' Munchers

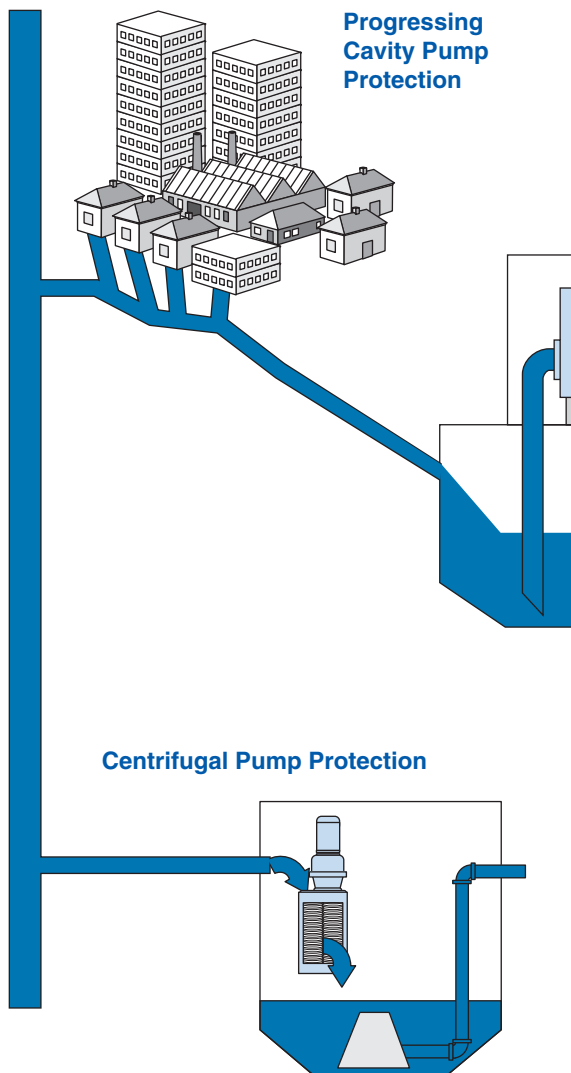

- Facilitates use of small bore rising main
- Effective macerator replacement
- 3 year warranty on raw sewage (SB Pipeline only)
- Full packaged pump stations available



- Single Muncher protects duty/standby pumps
- Above sewage installation
- Allows use of better efficiency pumps



# Applications - Inlet Works

## SB, Series 'A' and F Munchers

### In-flow Disintegration



- Small works automation
- Downstream system protection
- No removal costs
- Small footprint
- Minimal civil requirements

### Screening

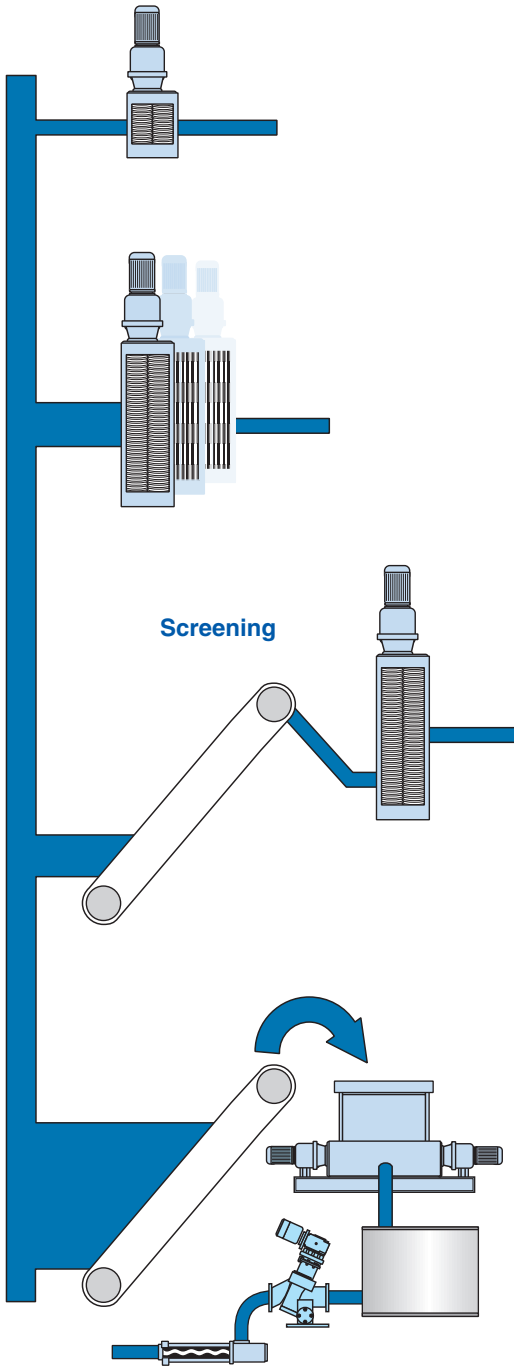

- Eliminate disposal costs
- Heavy duty capability
- Increase digester gas yield

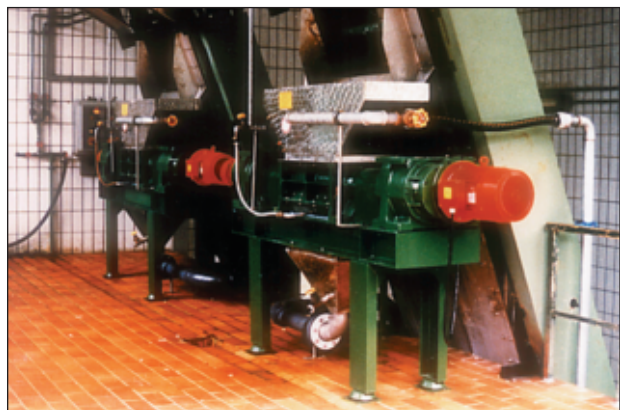

# Applications - Sludge

## SB, Series 'A' and TR Munchers

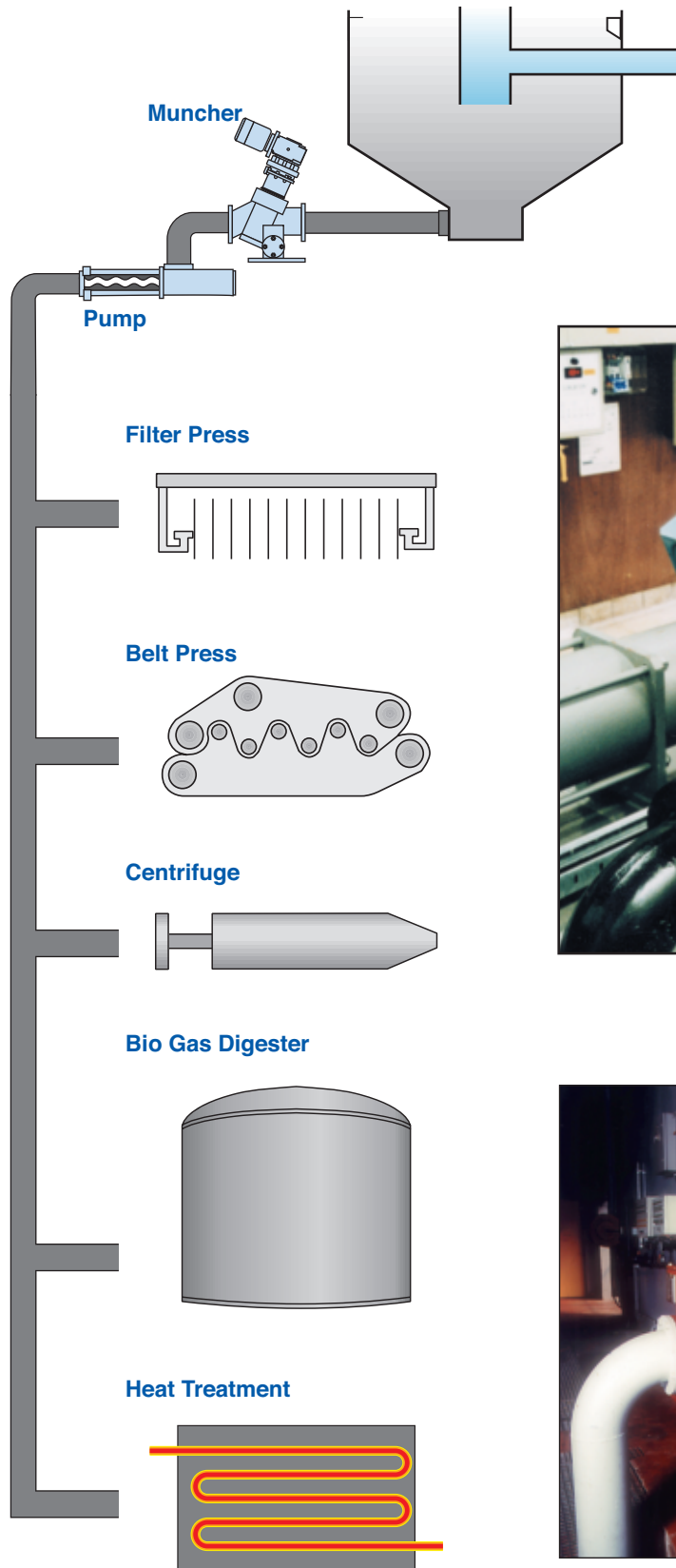

- Homogeneous sludge increases process efficiency
- Protects pumping equipment
- Prevents blockages

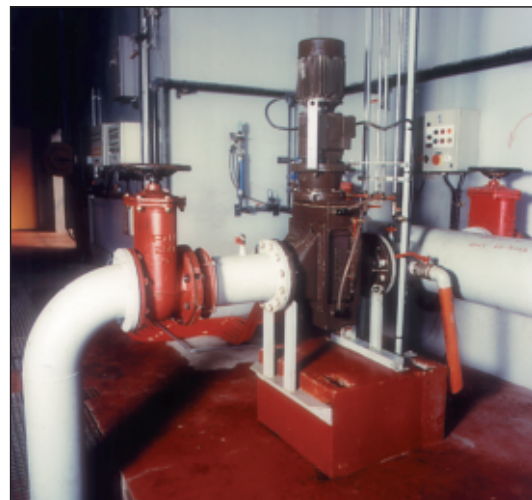

# Applications - Industrial

## Municipal or Industrial Incineration - Series 'A', TR and F Munchers

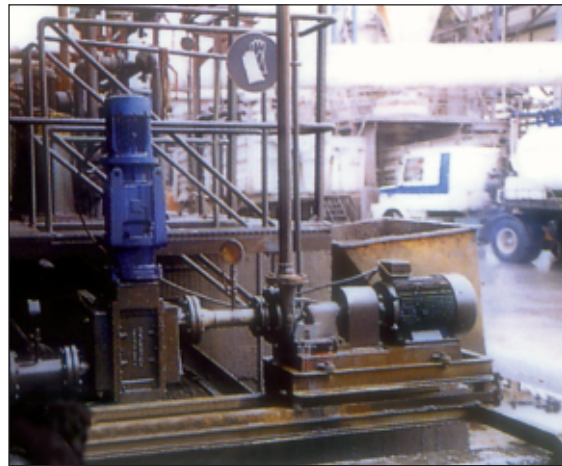
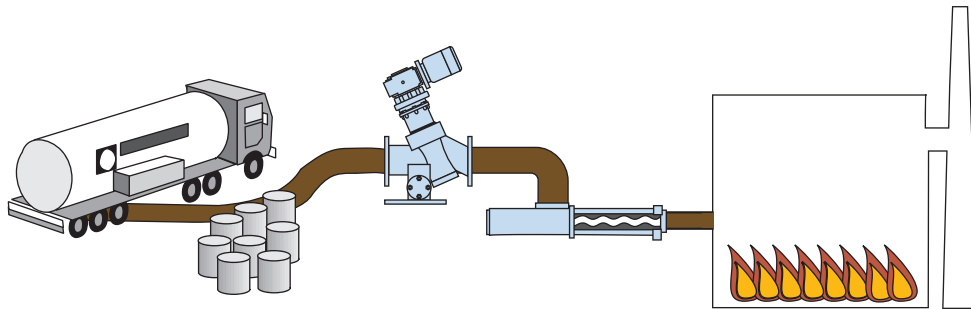

- Profit from waste
- Bulk reduction
- Product recycling

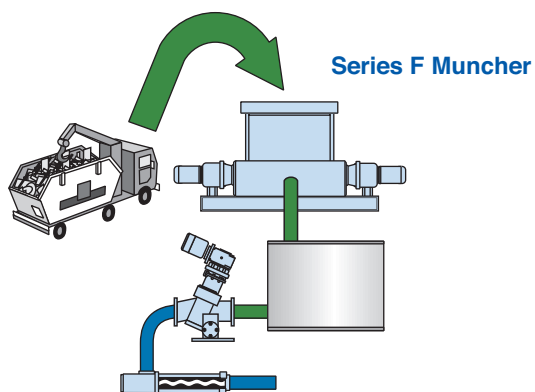

Organic Waste e.g. Food Processing Waste,  
Household Waste Fractions, Plant Thinnings Waste



# Capacities

## SB Muncher Range

### SB Pipeline Muncher

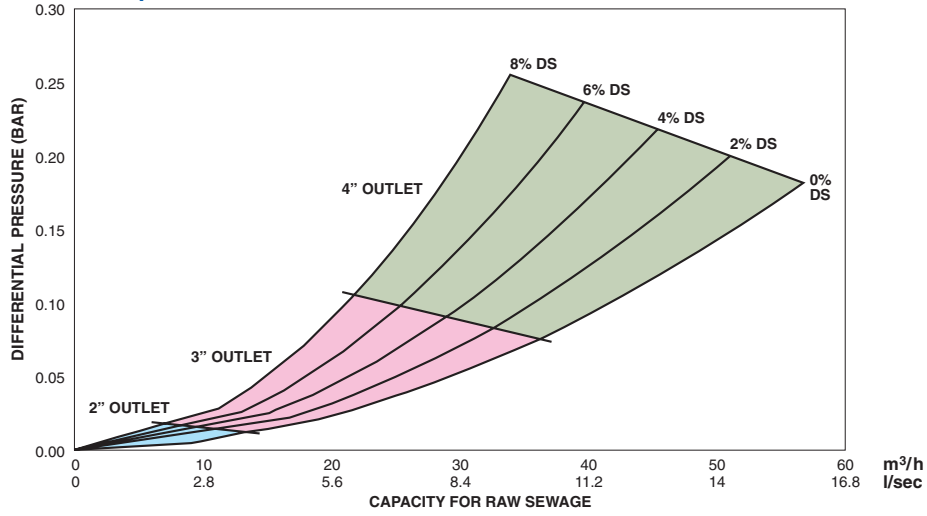

### SB Channel Muncher

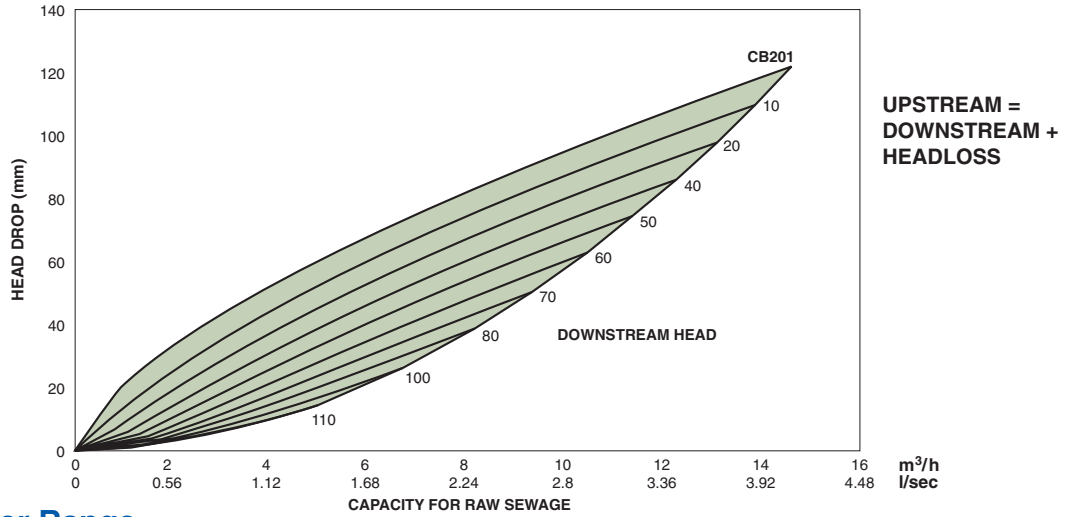

## TR Muncher Range

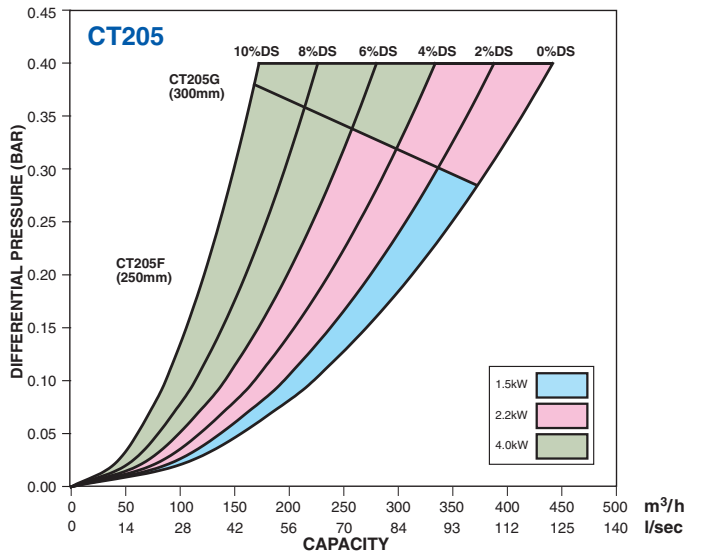
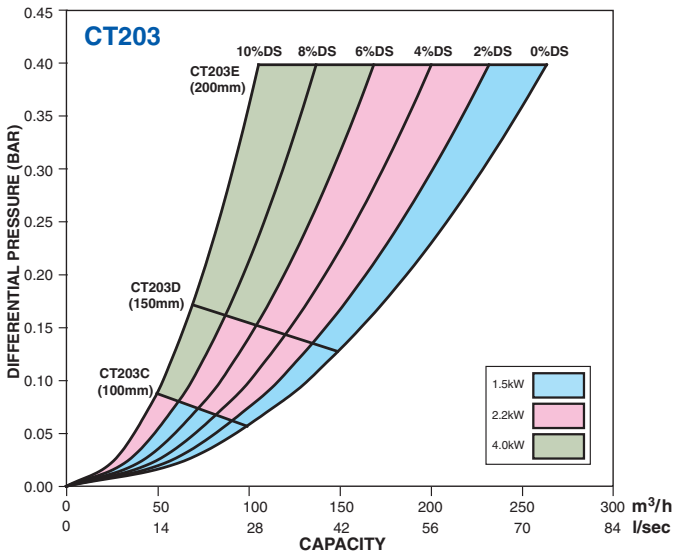

# Capacities

## Series 'A' Muncher Range

Standard Series 'A' Channel

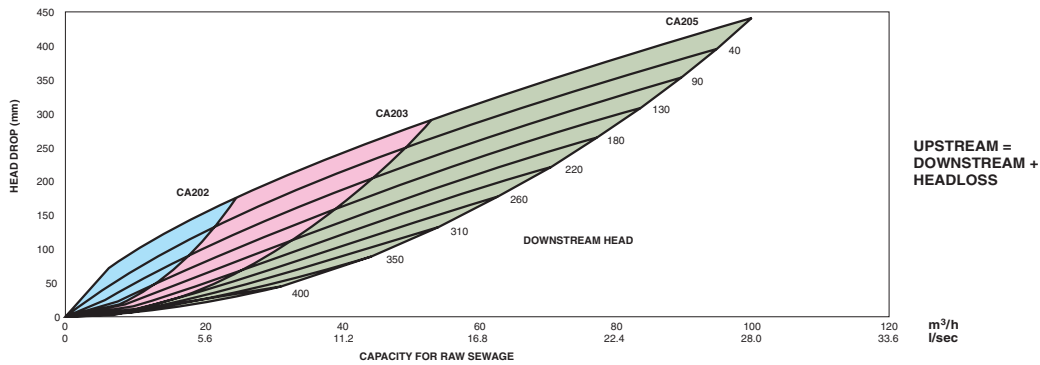

Standard Series 'A' Channel

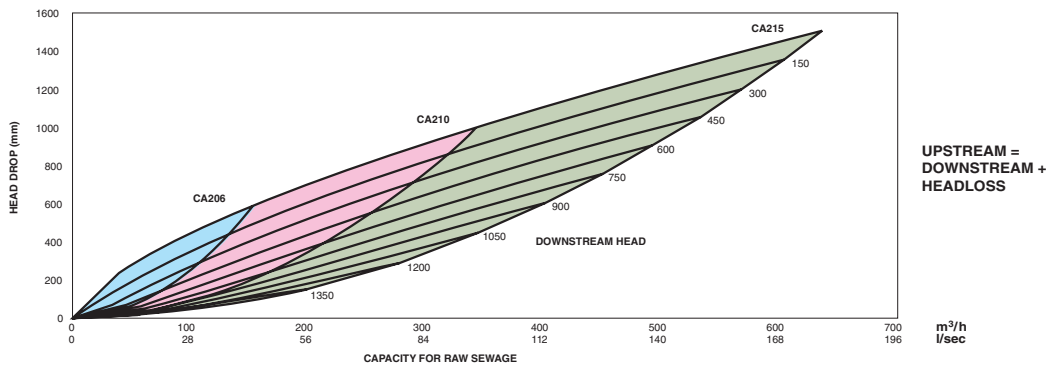

Extra Hi-Flow Series 'A' Channel

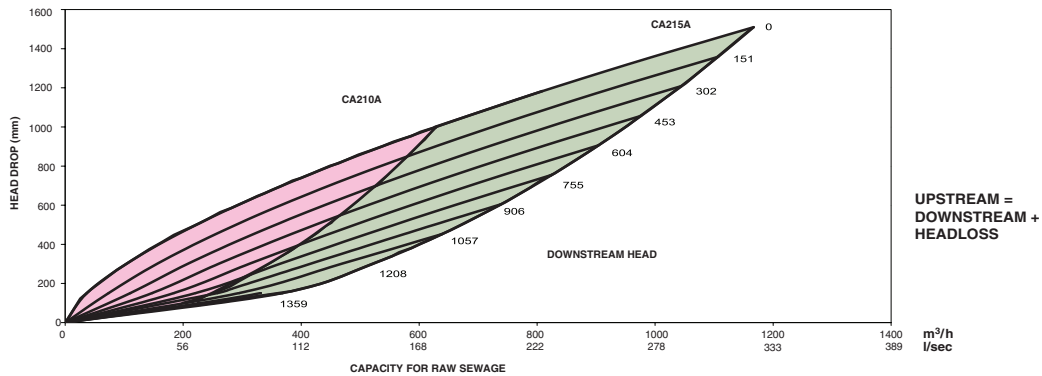

## Series F Muncher Range

### Typical Capabilities

Material		Machine Size	
		600mm Throat	1000mm Throat
Sewage screenings	m <sup>3</sup> /h	0-5	0-9
Screened refuse	m <sup>3</sup> /h	0-6	0-10
Composting material	m <sup>3</sup> /h	0-8	0-20
Alloy/tin cans	m <sup>3</sup> /h	0-2	0-5
Bio-waste	Kg/h	0-1200	0-4500

- 600mm throat with single drive (7.5kW)
- 1000mm throat with double drive (7.5kW and 5.5kW)

# G.A. Drawings

## SB Muncher

### Channel Unit

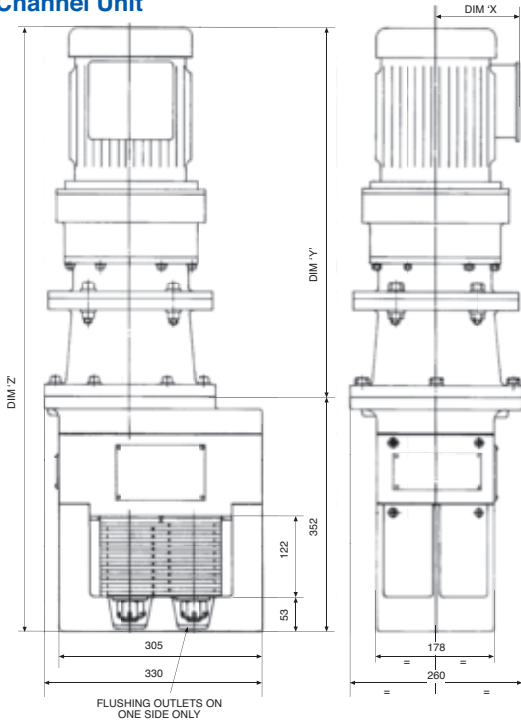

Motor		Dim 'X'	Dim 'Y'	Dim 'Z'	Weight kg
kW	IP				
1.1	55	135	657	1009	155
	67 & 68	241	679	1031	200
1.5	55	140	717	1069	190
	67 & 68	241	717	1069	225
2.2	55	154	739	1091	195
	67 & 68	289	746	1098	260

### Pipeline Unit with Baseplate

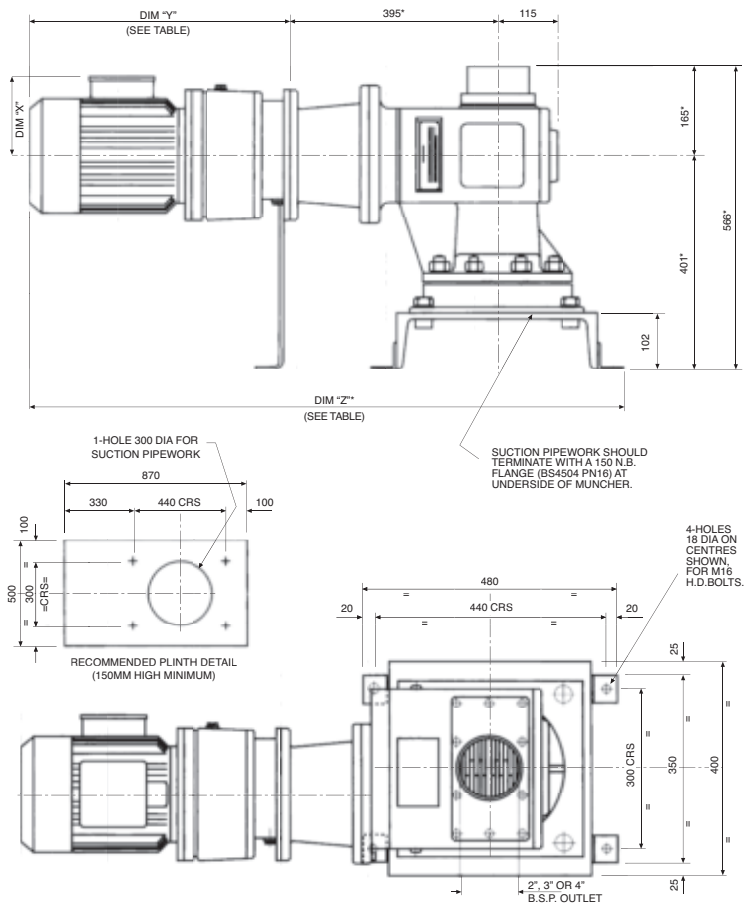

Motor	Dim 'X'	Dim 'Y'	Dim 'Z'	Weight kg
1.1kW	135	507	1142	208
1.5kW	140	567	1202	244
2.2kW	154	589	1224	248

## TR Muncher

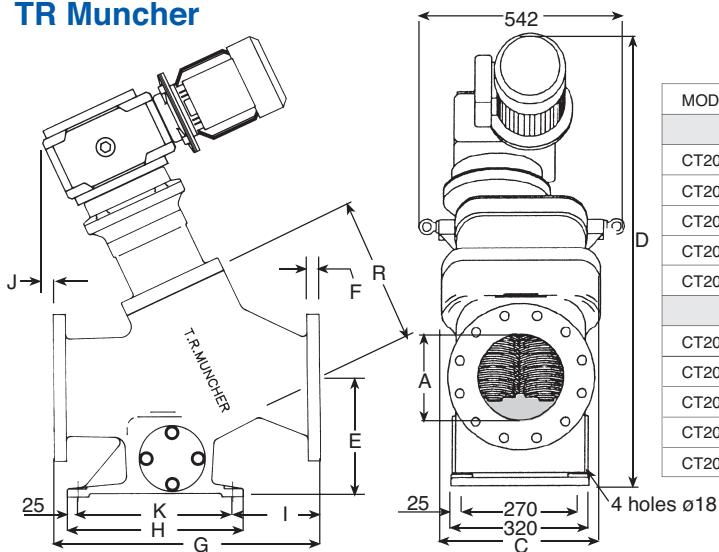

MODEL No.	A	C	D	E	F	G	H	I	J	K	R	MAX Wt kg
1.5 kW MOTOR												
CT203C	100	370	1020	205	24	489	410	124	140	360	363	290
CT203D	150	370	1050	230	25	540	410	155	40	360	354	290
CT203E	200	370	1050	256	29	591	410	205	16	360	341	290
CT205F	250	370	1190	281	32	692	460	205	30	410	494	345
CT205G	300	370	1190	332	32	794	460	263	-17	410	472	345
2.2 & 4.0 kW MOTOR												
CT203C	100	395	1130	205	24	489	410	124	169	360	363	340
CT203D	150	395	1170	230	25	540	410	155	97	360	354	340
CT203E	200	395	1170	256	29	591	410	205	72	360	341	340
CT205F	250	395	1310	281	32	692	460	205	87	410	494	390
CT205G	300	395	1310	332	32	794	460	263	40	410	472	390

All dimensions in mm unless stated otherwise.

# G.A. Drawings

## Series 'A' Muncher

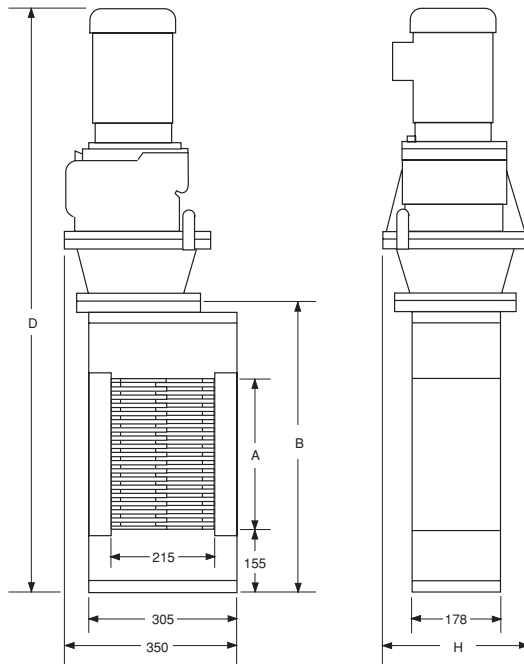

NOTE:  
 On IP67 & IP68 motor dimension D is increased by  
 74mm on 1.5kW motors.  
 18mm on 2.2kW motors.  
 165mm on 4.0kW motors.

### 1.5kW IP55 motors (dimensions in millimetres)

Model No.	A	B	D	H	Wt. kg
CA202AA	175	515	1080	260	220
CA203AA	290	629	1194	260	230
CA205AA	440	779	1344	260	255
CA206AA	585	924	1489	260	265
CA210AA	1000	1339	1904	260	330

### 2.2kW IP55 motors (dimensions in millimetres)

Model No.	A	B	D	H	Wt. kg
CA202AB	175	515	1146	260	235
CA203AB	290	629	1258	260	245
CA205AB	440	779	1408	260	265
CA206AB	585	924	1553	260	275
CA210AB	1000	1339	1970	260	350
CA215AB	1510	1849	2480	260	420

### 4.0kW motors IP55 (dimensions in millimetres)

Model No.	A	B	D	H	Wt. kg
CA202AC	175	515	1197	300	265
CA203AC	290	629	1311	300	275
CA205AC	440	779	1461	300	295
CA206AC	585	924	1606	300	305
CA210AC	1000	1339	2021	300	380
CA215AC	1510	1849	2533	300	450

## Series F Muncher

### 600mm Throat

Weight = 750kg  
 Unit Depth = 599mm  
 Drive = 7.5kW

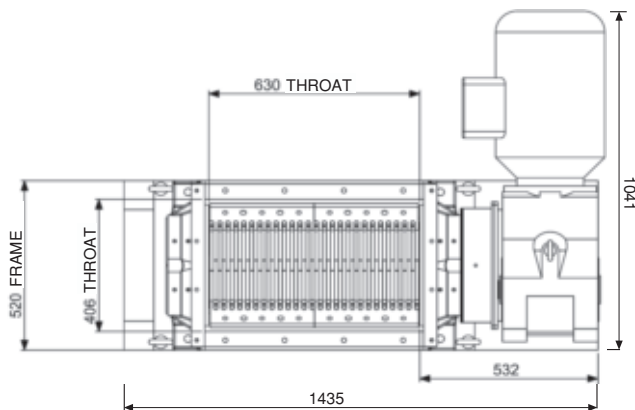

### 1000mm Throat

Weight = 1100kg  
 Unit Depth = 599mm  
 Drive = 7.5kW & 5.5kW

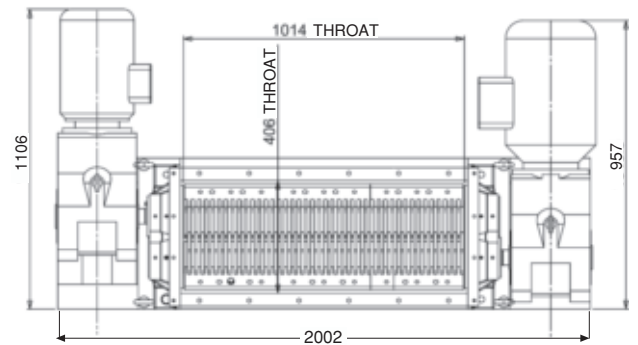

ALL DIMENSIONS IN MM UNLESS OTHERWISE STATED







Member of AxFlow Group

1300 4 BBENG  
www.brownbros.com.au



Member of AxFlow Group

0508 4 BBENG  
www.brownbros.co.nz

[www.mono-pumps.com](http://www.mono-pumps.com)



Published information other than that marked CERTIFIED does not extend any warranty or representation, expressed or implied, regarding these products. Any such warranties or other terms and conditions of sales and products shall be in accordance with Mono Pumps Limited standard terms and conditions of sale, available on request.

© 2014 Mono Pumps Limited. All Rights Reserved. Literature reference: SLWP/005/01/R15  
Mono™ and Muncher™ are registered trademarks of Mono Pumps Ltd.  
Registered in England No 300721



One Company, Unlimited Solutions