

# EZstrip™ Cake Pump



The EZstrip Cake Pump is designed with a large auger inlet and screw conveyor. The screw conveyor extends to the compression area to help push the sludge cake into the cavities of the rotor and stator and provide consistent pumping.

## Benefits and Features

The range is available in cast iron, with a choice of rotor and stator materials and a variety of hopper sizes.

- Quick and easy to maintain in place
- Reduced maintenance downtime and labour savings
- No need to disconnect suction and discharge pipework, even when removing the screw conveyor
- Detachable feed chamber supplied as standard
- WIMES specification Efficiency 1 motors supplied as standard

## Capacity

Up to 49 m<sup>3</sup>/h

## Pressure

Up to 24 bar

## Temperature

-10°C up to 100°C

## Typical applications

Thickened sludge cake (up to 40% dry solids content), dewatered sludge, sludge blending, including lime powder dosing and lime slurry dosing in conjunction with barrier layer injection.



# EZstrip Cake Pump

To minimize the downtime and cost involved when maintaining a progressing cavity pump, the EZstrip Cake Pump can be fully maintained in place, without disconnecting pipework or removing the hopper.

Once the pumping elements have been disconnected, the middle support foot allows the feed chamber and rotor and stator to be turned, to assist removal of these parts. Alternatively, the complete assembly can be lifted out and returned to your workshop or bench for maintenance.

A full drive train including rotor, stator and screw conveyor can be removed in just 8 minutes using standard tools.

## Sludge Treatment Applications

- Blending
- Thickening
- Lime Slurry Dosing
- Dewatering
- Lime Powder Dosing
- Barrier Layer Injection
- Digestion

## Performance Data



For higher flow rates and pressures, please contact NOV.

## Dimensions

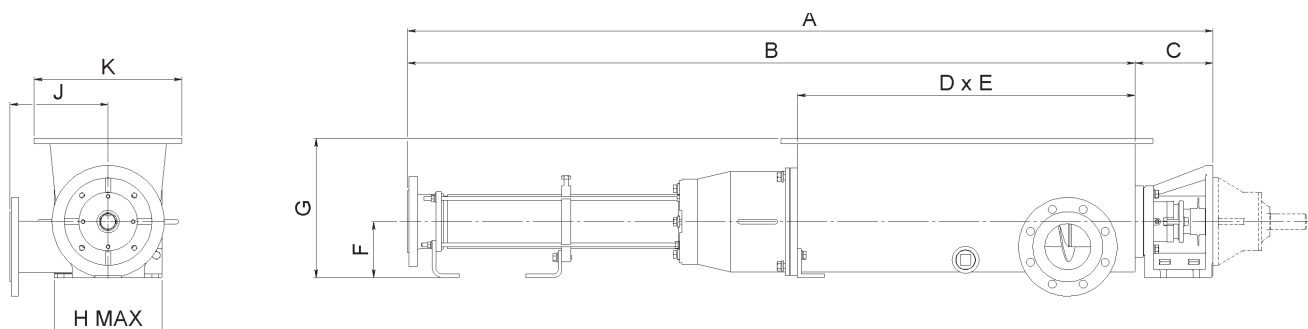

MODEL	A	B	C	D	E	F	G	H	J	K
W14B	1636	1468	168	750	250	112	282	210	270	290
W14D	2084	1907	177	750	250	125	295	210	270	290
W15B	1797	1623	174	750	250	125	310	240	320	290
W15D	2386	2182	204	750	250	150	335	240	320	290
W16B	2216	2012	204	1000	360	150	375	290	320	400
W16D	2923	2691	232	1000	360	160	382	290	320	400
W17B	2410	2202	208	1000	360	175	415	335	320	400
W17D	3352	3089	263	1000	360	225	465	335	320	400
W18B	2584	2343	241	1000	360	225	505	385	350	400
W18D	3533	3268	265	1000	360	225	505	400	350	400
W19B	2768	2535	233	1000	360	225	505	430	350	400
W19D	3100	2834	266	1000	360	250	550	475	350	400

\* Can be supplied with either fixed speed inverter rated or mechanical variable speed drive.

All dimensions in mm's and for guidance only. For full certified drawings, please contact NOV.



Member of AxFlow Group

1300 4 BBENG  
www.brownbros.com.au



Member of AxFlow Group

0508 4 BBENG  
www.brownbros.co.nz