

Low Flow Metering Range

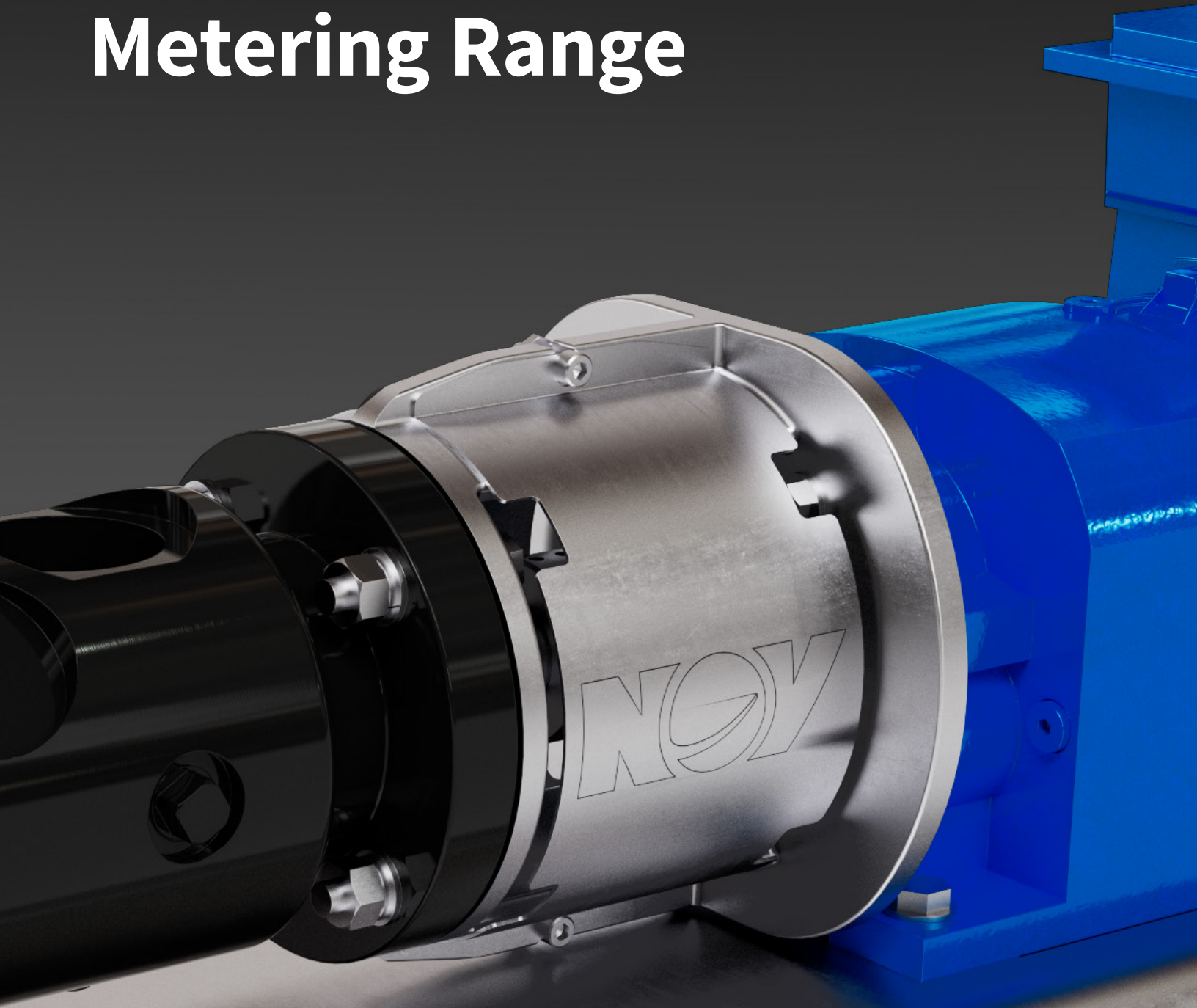

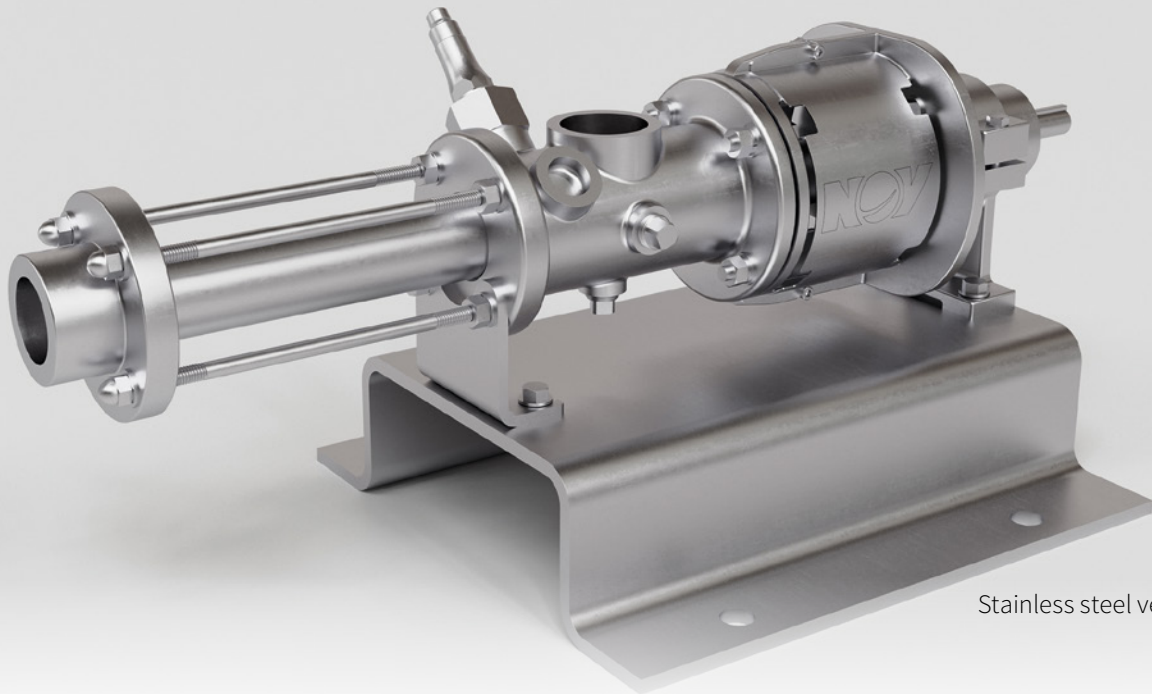

Stainless steel version

Low Flow Metering Range

The Low Flow Metering range includes enhanced element offerings with improved precision metering control technology, reduced break-out torque, and excellent slow-speed performance. The elements help to expand the scope of metering applications for your customer, while still supplying each fluid with a smooth, pulsation-free flow.

Mono and Moyno metering pump advantages:

- Handles abrasives, corrosives, solids in suspension, and viscous fluids
- Works with pressures to 300 psi or 24 bar
- Self-priming, high suction lift capability
- Low shear pumping action
- Low power consumption and operating costs
- No valves to clog, stick, or vapor lock
- Pressure capability is independent of speed
- Compatible with Integral VFD/Motor Controls

Applications:

The use of different stator materials enables the pump to be used for a wide range of products, including:

- Acids and alkalis
- Cosmetics
- Food ingredients
- Brewing and winemaking
- Process mining
- Dyes and inks
- Flocculants
- Water and wastewater chemical injection
- Food and beverage flavoring's transfer
- Chemical processing for various industries
- Pulp and paper, pumping titanium dioxide
- Pharmaceutical industry, handling fillers
- Pastes and gels

Key performance details

Capacity – 0 to 1.29m³/hr or 0 to 341 US gph

Pressure – up to 348 psi or 24 bar

Temperature - 100°C

Highly repeatable accuracy

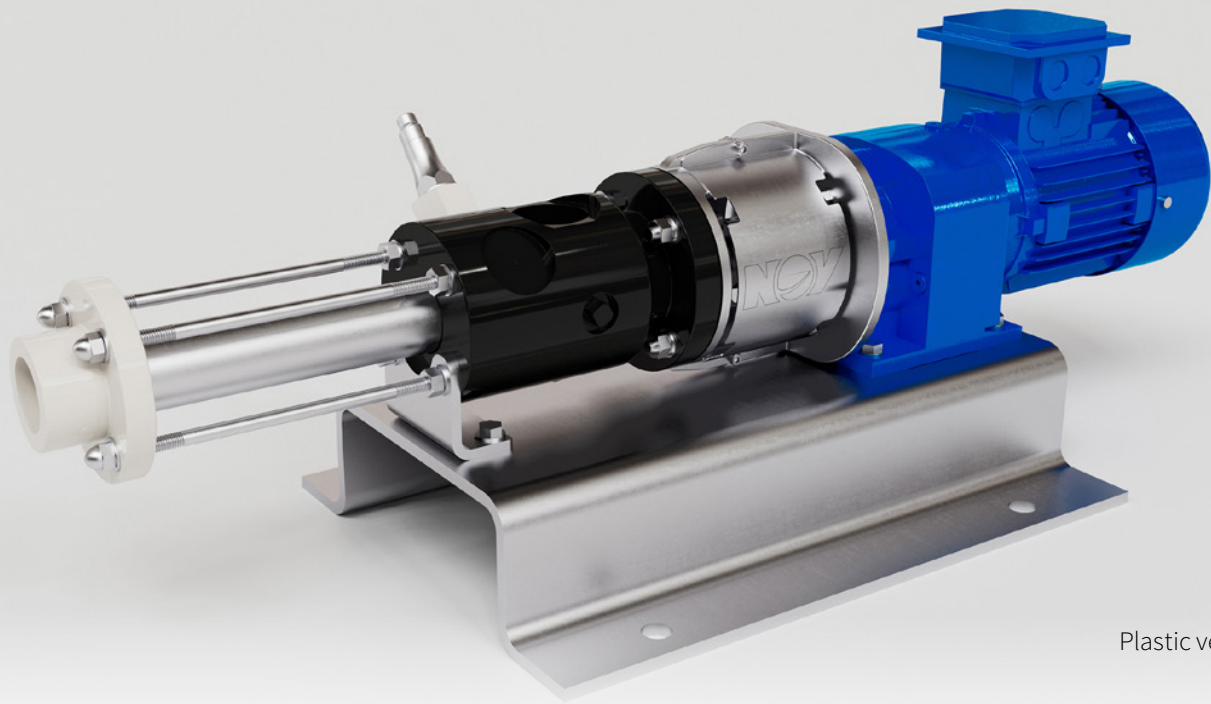

Plastic version

Choose accuracy, reliability, and simplicity

Moyno and Mono have been at the forefront of progressing cavity pump design since 1936. Our experience supports the vast array of needs facing our global customer base. It also enables us to develop high quality solutions which lead to efficiency improvements across dozens of industries.

Designed for use where accurate, low flow dosing or transfer pumps are required for either intermittent or continuous dosing, the Low Flow Metering range has high tolerance to aggressive chemicals (0-14PH) and is backed by the renowned reliability of Mono and Moyno products. The pumps have a repeatability of $\pm 1\%$, and the gentle pumping action makes it ideal for pumping delicate, shear-sensitive products.

Rotor and stator

The rotor form results in excellent hydraulic performance, reduced break-out torque, and excellent slow speed performance. Stators are available in a variety of materials, allowing for a wide range of products to be pumped.

Materials of construction

All pump components, except the body, coupling rod and suction chamber are supplied in stainless steel. The suction chamber is manufactured in high-density polyethylene. The end cover and mechanical seal housing is PVDF. For severe chemical environments, internal pump components are supplied in Hastelloy.

Fully sealed joints

Fully sealed drive train to maximize life and minimize downtime.

Shaft sealing

Packing, single, and double mechanical seals are available in a variety of materials to support the most corrosive applications.

Gearbox and motor options

Options available include close coupled, long coupled, synchronous speed motor, fixed speed gearbox, and frequency inverter. Other options available on request.

Accessories

- Integrated inverter
- Flow sensor
- Over pressure protection
- RPM control

Smart controls and pumping

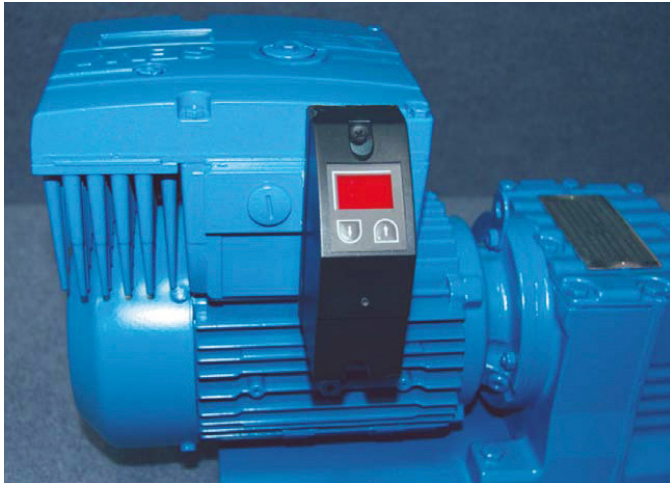

Moyno integral VFD/motor control for that precision metering you demand

The latest motor control enhancements, plus decades of metering pump experience equal a winning combination for you.

About our VFD offering

Moyno offers a wide range of integral VFD/motor controls for improved metering accuracy and repeatability. You have the choice of two global motor suppliers to choose from, the Nord® SK 200E and 300E Trio, and SEW Eurodrive Movimot®.



Flow meter

The Smart Metering pump is supplied with an integrated PLC and inverter allowing sensors on the pump to provide feedback on the operating conditions. Set points can then be programmed for the specific application allowing the pump to correct any deviations from the required duty, no matter how small.

This simplifies automation system integration and reduces the cost of installation.

Sensor data can be fed into our digitization system allowing for remote monitoring and predictive maintenance reducing operations cost effectively, optimize process times and minimizing downtime.

Work smarter, not harder, with an optional equipment upgrade.

GoConnect™ real-time condition monitoring application Reduce maintenance costs, extend the life of your assets, and avoid unplanned downtime through monitoring vibration, bearing temperature, and motor current.

Application Engineering Support

Have a question about positive displacement process metering pumps? Would you like to discuss requirements for a specific application? Moyno/Mono technical personnel are available to answer questions and assist you in making the right selection. Contact Moyno/Mono today for experienced metering application engineering support.

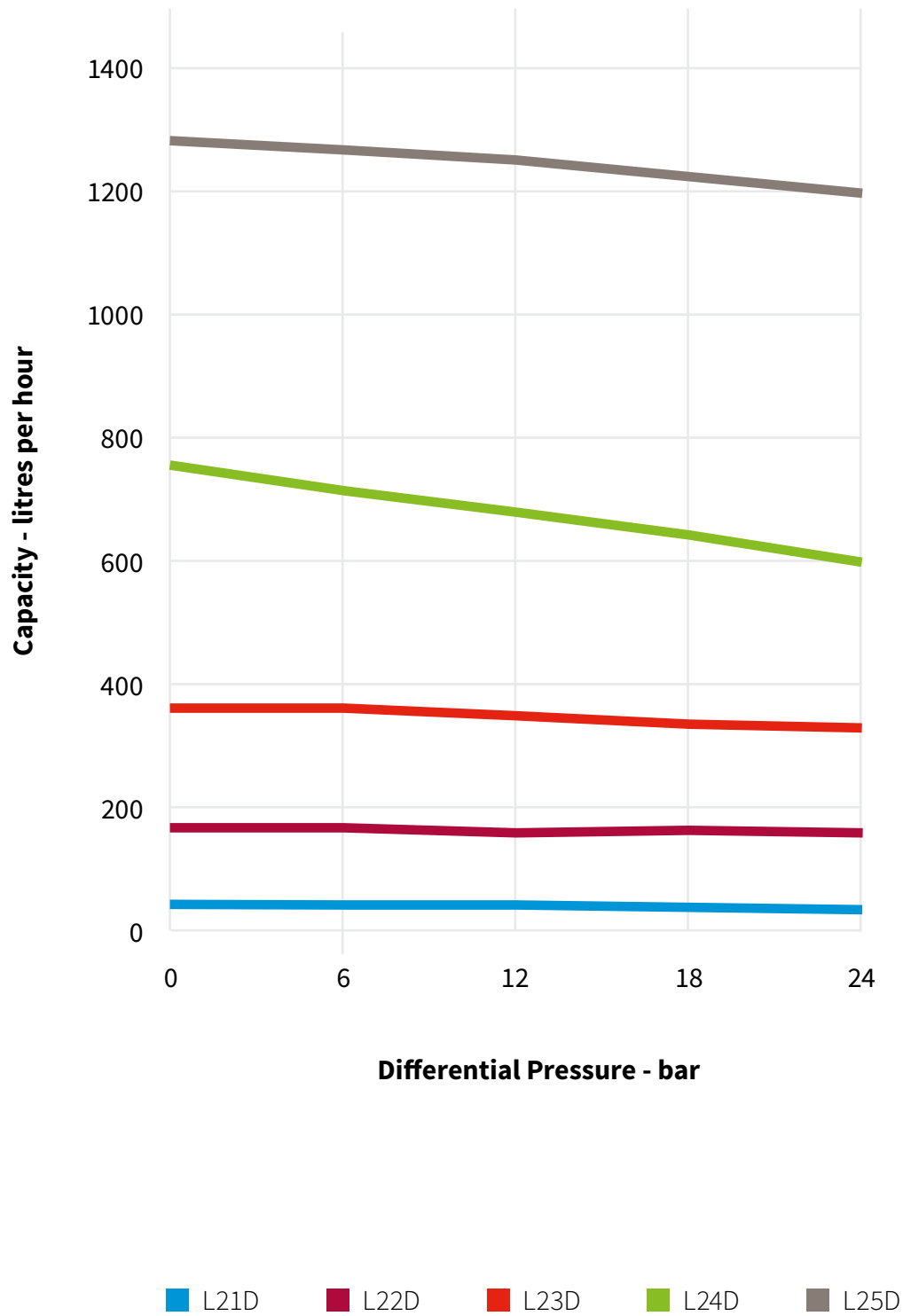

Dosing Bareshaft GA

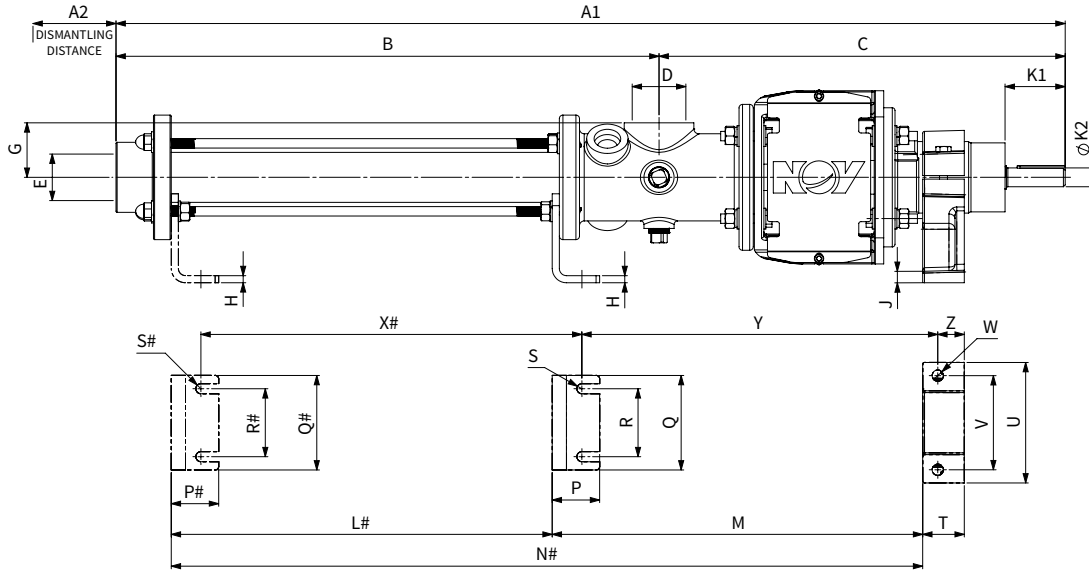

Model	A1		A2		B		C		D		E		G		H		J		K1		K2		L		M	
	mm	in.	mm	in.	mm	in.	mm	in.	BSPP	NPT	BSPP	NPT	mm	in.	mm	in.	mm	in.	mm	in.	mm	in.	mm	in.	mm	in.
L21D	540.6	21.28	131.0	5.16	198.1	7.80	342.5	13.48	1.5"-11	1.5"-11.5	1.25"-11	1.25"-11.5	46.00	1.81	6	0.24	10	0.39	50.8	2	15.88	%	-	-	312.4	12.30
L22D	581.7	22.90	172.0	6.78	239.2	9.42	342.5	13.48	1.5"-11	1.5"-11.5	1.25"-11	1.25"-11.5	46.00	1.81	6	0.24	10	0.39	50.8	2	15.88	%	-	-	312.4	12.30
L23D	583.2	22.96	174.0	6.84	240.8	9.48	342.5	13.48	1.5"-11	1.5"-11.5	1.25"-11	1.25"-11.5	46.00	1.81	6	0.24	10	0.39	50.8	2	15.88	%	-	-	312.4	12.30
L24D	648.4	25.53	239.0	9.40	305.9	12.04	342.5	13.48	1.5"-11	1.5"-11.5	1.25"-11	1.25"-11.5	46.00	1.81	6	0.24	10	0.39	50.8	2	15.88	%	-	-	312.4	12.30
L25D	800.4	31.51	392.0	15.43	457.9	18.03	342.5	13.48	1.5"-11	1.5"-11.5	1.25"-11	1.25"-11.5	46.00	1.81	6	0.24	10	0.39	50.8	2	15.88	%	321.3	12.65	312.4	12.30

Model	N		P		Q		R		S		T		U		V		W		X		Y		Z	
	mm	in.	mm	in.	mm	in.	mm	in.	mm	in.	mm	in.	mm	in.	mm	in.	mm	in.	mm	in.	mm	in.	mm	in.
L21D	-	-	40	1.57	79.8	3.14	57.3	2.26	Ø 8.5	.33 for % ₁₆	35.1	1.38	101.6	4	79.2	3.12	Ø 9.5	% for % ₁₆	-	-	300.1	11.81	22.4	0.88
L22D	-	-	40	1.57	79.8	3.14	57.3	2.26	Ø 8.5	.33 for % ₁₆	35.1	1.38	101.6	4	79.2	3.12	Ø 9.5	% for % ₁₆	-	-	300.1	11.81	22.4	0.88
L23D	-	-	40	1.57	79.8	3.14	57.3	2.26	Ø 8.5	.33 for % ₁₆	35.1	1.38	101.6	4	79.2	3.12	Ø 9.5	% for % ₁₆	-	-	300.1	11.81	22.4	0.88
L24D	-	-	40	1.57	79.8	3.14	57.3	2.26	Ø 8.5	.33 for % ₁₆	35.1	1.38	101.6	4	79.2	3.12	Ø 9.5	% for % ₁₆	-	-	300.1	11.81	22.4	0.88
L25D	633.7	24.95	40	1.57	79.8	3.14	57.3	2.26	Ø 8.5	.33 for % ₁₆	35.1	1.38	101.6	4	79.2	3.12	Ø 9.5	% for % ₁₆	321.3	12.65	300.1	11.81	22.4	0.88

Dosing Close Coupled GA

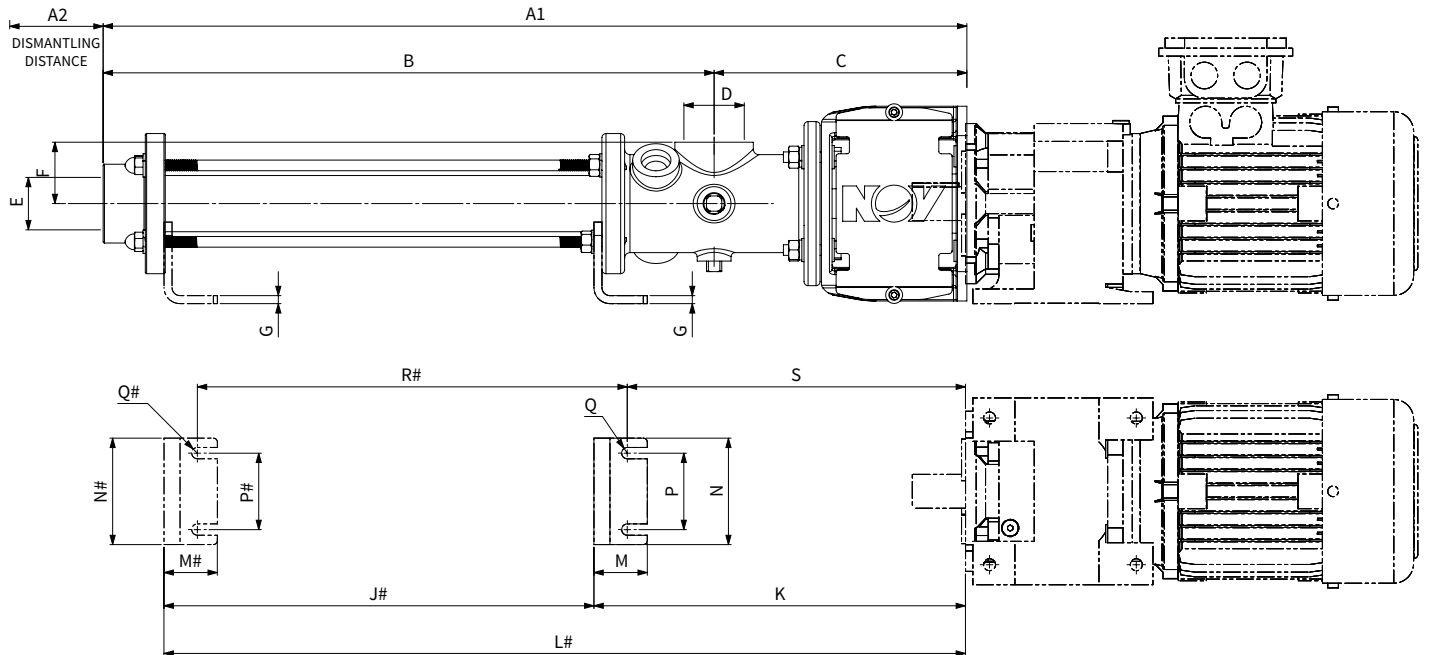

	A1		A2		B		C		D		E		F		G		J	
Model	mm	in.	mm	in.	mm	in.	mm	in.	BSPP	NPT	BSPP	NPT	mm	in.	mm	in.	mm	in.
L21D	387.5	15.26	131.0	5.16	198.1	7.80	189.4	7.46	1.5"-11	1.5"-11.5	1.25"-11	1.25"-11.5	46.00	1.81	6.00	0.24	-	-
L22D	428.6	16.87	172.0	6.78	239.2	9.42	189.4	7.46	1.5"-11	1.5"-11.5	1.25"-11	1.25"-11.5	46.00	1.81	6.00	0.24	-	-
L23D	430.2	16.94	174.0	6.84	240.8	9.48	189.4	7.46	1.5"-11	1.5"-11.5	1.25"-11	1.25"-11.5	46.00	1.81	6.00	0.24	-	-
L24D	495.3	19.50	239.0	9.40	305.9	12.04	189.4	7.46	1.5"-11	1.5"-11.5	1.25"-11	1.25"-11.5	46.00	1.81	6.00	0.24	-	-
L25D	647.4	25.49	392.0	15.43	457.9	18.03	189.4	7.46	1.5"-11	1.5"-11.5	1.25"-11	1.25"-11.5	46.00	1.81	6.00	0.24	321.3	12.65

	K		L		M		N		P		Q		R		S	
Model	mm	in.	mm	in.	mm	in.	mm	in.	mm	in.	mm	in.	mm	in.	mm	in.
L21D	279.5	11.00	-	-	40	1.57	79.8	3.14	57.3	2.26	Ø 8.5	.33 for 1/8"	-	-	254.5	10.02
L22D	279.5	11.00	-	-	40	1.57	79.8	3.14	57.3	2.26	Ø 8.5	.33 for 1/8"	-	-	254.5	10.02
L23D	279.5	11.00	-	-	40	1.57	79.8	3.14	57.3	2.26	Ø 8.5	.33 for 1/8"	-	-	254.5	10.02
L24D	279.5	11.00	-	-	40	1.57	79.8	3.14	57.3	2.26	Ø 8.5	.33 for 1/8"	-	-	254.5	10.02
L25D	279.5	11.00	600.8	23.65	40	1.57	79.8	3.14	57.3	2.26	Ø 8.5	.33 for 1/8"	321.3	12.65	254.5	10.02



Member of AxFlow Group

1300 4 BBENG
www.brownbros.com.au



Member of AxFlow Group

0508 4 BBENG
www.brownbros.co.nz

