

## W+ Series

SANITARY CENTRIFUGAL PUMPS



SPX FLOW is a leading innovator of solutions with decades of experience in centrifugal pump design, covering premium brands such as APV and Waukesha Cherry-Burrell. From the supply of engineered components to complete process engineering and design, we specialize in helping our customers improve their plant's performance and profitability.

Years of intensive product development on a worldwide scale, has enabled SPX FLOW to offer a complete range of hygienic pumps in the brewery, dairy, food, beverage, chemical, health care and pharmaceutical industries.

SPX FLOW, Inc. (NYSE:FLOW) is a leading manufacturer of innovative flow technologies, many of which help define the industry standard in the market segments they serve. From its headquarters in Charlotte, North Carolina, it operates a sales and support network, centers of manufacturing excellence, and advanced engineering facilities throughout the world. Its cutting-edge flow components and process equipment portfolio includes a wide range of pumps, valves, heat exchangers, mixers, homogenizers, separators, filters, UHT, and drying technology that meet many application needs. Its expert engineering capability also makes it a premium supplier of customized solutions and complete, turn-key packages to meet the most exacting of installation demands.

Incorporating many leading brands, SPX FLOW has a long history of serving the food and beverage, power and energy, and industrial market sectors. Its designs and engineered solutions help customers drive efficiency and productivity, increase quality and reliability, and meet the latest regulatory demands. In-depth understanding of applications and processes, state-of-the-art Innovation Centers, and advanced pilot/testing technology further assist in optimizing processes and reducing timescales to reliably meet production targets.

To learn more about SPX FLOW capabilities, its latest technology innovations and complete service offerings, please visit [www.spxflow.com](http://www.spxflow.com).

## W+ Advanced Design for Performance and Reliability

APV brand W+ centrifugal pumps from SPX FLOW are designed to achieve total cost optimization with high efficiency and product dependability. They are installed in countless process facilities around the world helping producers meet stringent production requirements.

The W+ Pump runs with the same rugged reliability you've come to expect from SPX FLOW products. Its versatile design helps increase process efficiency and maximize productivity while offering several innovative features such as:

### FEATURES AND BENEFITS

- Reliable and heavy duty design
- Energy efficient
- Quiet performance with minimal vibration
- Superior shaft seal design
- High pressure capability
- 3-A
- Designed for CIP (Cleaning In Place) as well as SIP (Sterilizing In Place)
- Suitable for a wide variety of food, beverage and pharmaceutical products
- Wide range of optional features available
- Easy and cost effective maintenance

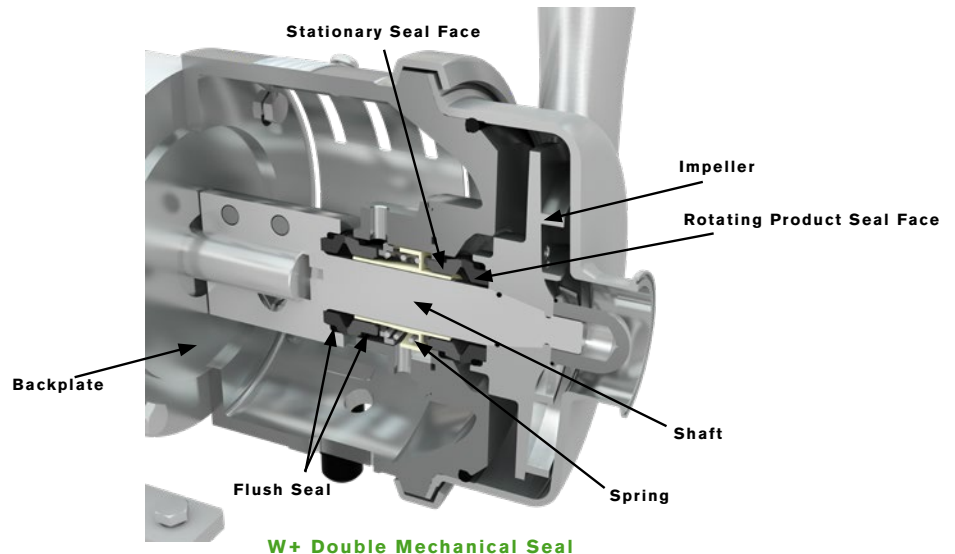

W+ Single Mechanical Seal

W+ Inducer Pump

W+ Self-Priming Pump

The product seal is the essential area in terms of hygiene. The pumps are equipped with a product seal that is ideal for hygienic applications.

**Seal Advantages:**

- Internal seal design optimizes cooling and lubrication of seal surfaces while the seal chamber is built to efficiently dissipate heat. Both work to reduce risk of "dry-running"
- Directed flow assures thorough cleaning of seal area
- The stationary spring is located outside the product contact area to maintain cleanliness
- Two sizes cover all models
- Front loading seal simplifies maintenance: only the pump housing and impeller have to be disassembled, then the product seal faces can be replaced quickly from the front
- Can easily be rebuilt into a double mechanical shaft seal for use with water flushing or with a barrier medium for aseptic applications
- Double mechanical is mirror image of single: same seal faces and o-rings

**THEORY OF OPERATION**

The W+ pump series is based on a proven hydraulic design that promotes high operational efficiency and reduces noise and vibration levels while maintaining hygienic standards.

Low viscous fluids enter through the center inlet and flow around the impeller which turns at various speeds based on application requirements. The fluid then moves to the outer extents of the impeller vanes by centrifugal force and is directed through the outlet. As with other SPX FLOW centrifugal pumps, impeller and casing designs are optimized to perform more efficiently over a wide range of operating conditions. The casing and port are further designed to maximize performance under low NPSH conditions.

- **Item 1** - Unique APV spiral volute positioned in the backplate of the pump ensures a direct transfer of liquid from inlet to outlet
- **Item 2** - Advanced, high efficiency impeller design
- **Item 3** - Extended outlets smooth transition to process piping while reducing turbulence and preventing product build-up
- **Item 4** - Heavy walled pump casing insures that efficiency levels are maintained even at high pressure



Typical product applications

**Bakery and Confectionery**

- Batters
- Fats & Oils
- Flavorings
- Sweeteners
- Yeast Slurry
- Syrups



**Dairy**

- Whey
- Cream, Milk
- Sweetened Condensed
- RO/UF Systems



**Pharmaceutical/Cosmetics**

- Emulsions
- Extracts
- Slurries
- Syrups
- Dyes, Alcohols
- Essential Oils



**Chemical/Industrial**

- Detergents
- Dyes
- Soap Liquors & Solutions
- Ammonium Nitrate
- Propyl Alcohol
- Potassium Chloride
- Sodium Acetate



## PRODUCT SPECIFICATIONS

MATERIALS	
CASING	SS 316L
IMPELLER	SS 316L
IMPELLER NUT	SS 316L
BACK PLATE	SS 316L
SHAFT	SS 316L
CLAMP RING	SS 304
ADAPTOR	SS 304
SUPPORT	SS 304
SHAFT SEAL	Carbon/Silicon Carbide Optional: Silicon Carbide/Silicon Carbide
ELASTOMERS	FKM Optional: EPDM, PTFE

TECHNICAL DATA	
MAX. DISCHARGE PRESSURE	260 psi (18 bar): W+10/8, W+22/20, W+30/80, W+35/55, W+35/35, W+110/130 200 psi (14 bar): W+25/210, W+30/120, W+50/8, W+55/35, W+55/60, W+60/110, W+65/350, W+70/40, W+80/80 Optional: Heavy duty clamping ring, increasing max. outlet pressure to 360 psi (25 bar): W+30/120, W+55/35, W+55/60, W+60/110, W+70/40 290 psi (20 bar): W+80/80
MAX. OPERATING TEMPERATURE	203°F (95°C) as standard. >203°F, please contact SPX FLOW

PORT CONNECTIONS	
Tri-clamp® connections are standard. Bevel seat, I-line, ISO and other standard fittings are available as well as special aseptic connections for sterile flushing of Wa+.	

MOTOR	
TEFC or Washdown enclosures available. Energy-efficient, Chem-duty, Explosion Proof and stainless steel also available, as well as single phase or three phase, 60 or 50 Hertz.	

MODEL	INLET SIZE		OUTLET SIZE		MAXIMUM IMPELLER SIZE		MAXIMUM CAPACITY (GPM)		MAXIMUM HEAD (FT)	
	INCH	mm	INCH	mm	INCH	mm	1750 RPM	3500 RPM	1750 RPM	3500 RPM
10/8	1.5	38	1	25	4.3	110	32	65	17	68
22/20	2	51	2	51	5.6	142	85	175	34	138
25/210	6	152	4	102	11.4	290	1610	-	134	-
30/80	4	102	3	76	6.7	170	315	650	43	171
30/120	4	102	3	76	6.9	175	410	810	47	190
35/35	2.5	65	2	51	6.9	175	142	280	49	198
35/55	3	76	2.5	65	7.1	180	230	465	50	200
50/8	1.5	38	1	25	7.9	200	42	85	68	275
55/35	2.5	65	1.5	38	8.3	210	140	245	76	302
55/60	3	76	2	51	8.7	220	305	615	78	315
60/110	4	102	3	76	9.1	230	475	975	90	359
65/350	6	152	4	102	10.2	260	1250	2300	100	400
70/40	2.5	65	1.5	38	9.4	240	110	235	98	390
80/80	3	76	2	51	10	255	310	625	112	450
110/130	4	102	76	76	11.4	290	575	1050	150	600

## ADDITIONAL TECHNICAL DATA

### A comprehensive range

The W+ range consists of several standard models with pressure and flow capacities to 360 psi (25 bar) and to 2,300 GPM (522 m<sup>3</sup>/hr), and a number of special versions which may be specifically adapted to customer requirements. The W+ pumps are modular so that any pumping job can be done with a perfectly customized W+ pump.

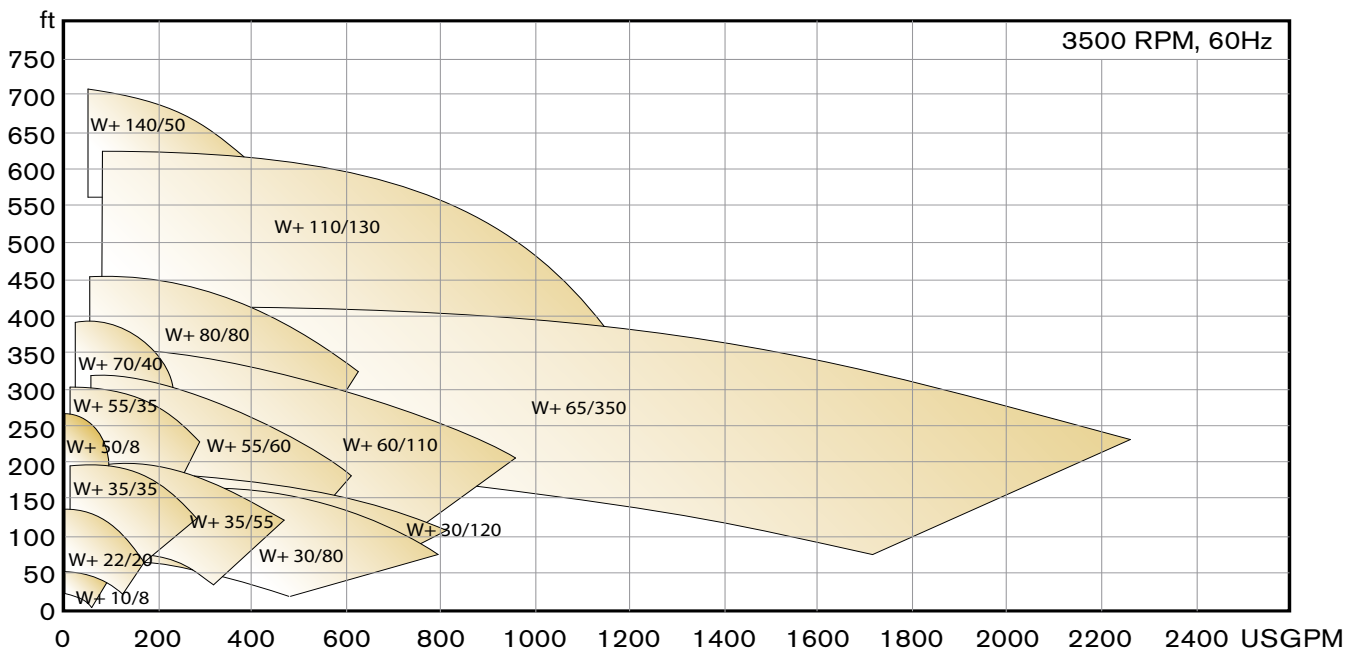
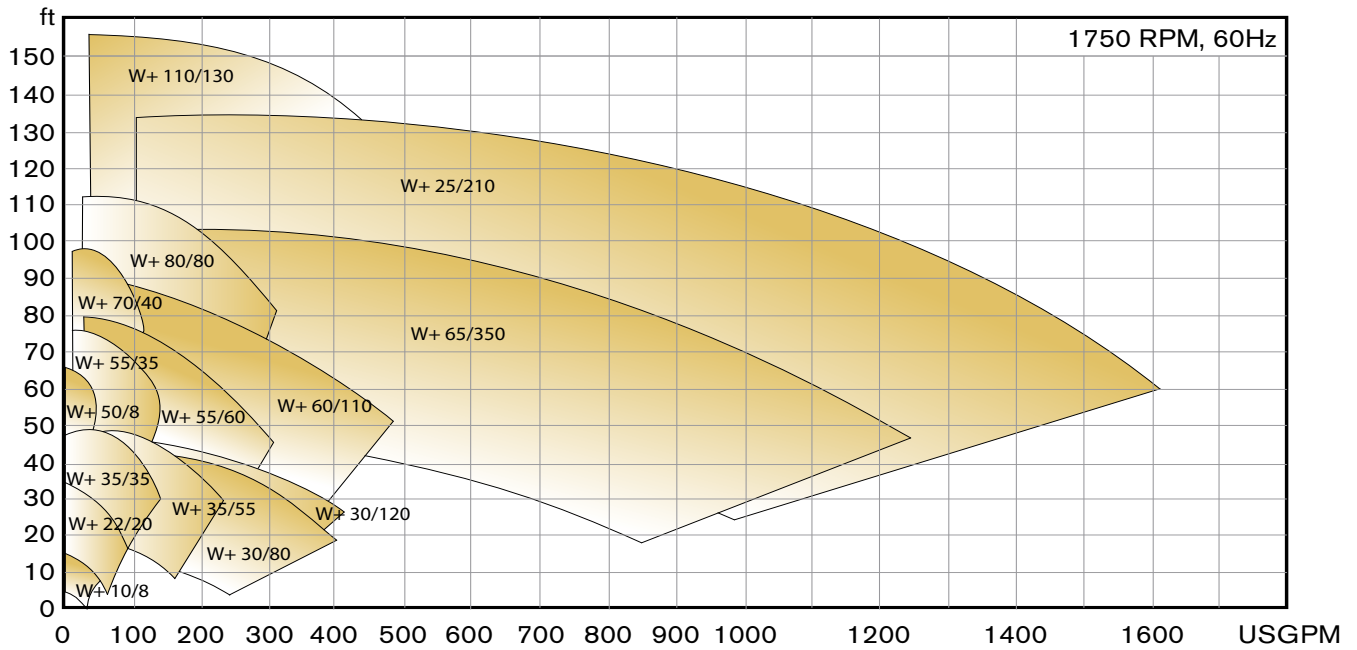

## OPTIONS AND ACCESSORIES

### Variants of the W+

#### WI+ INDUCER PUMP



The inducer pump is the alternative to changing the process design when NPSH availability is low. The inducer boosts the inlet pressure, and the risk of cavitation is correspondingly reduced (the NPSH required typically drops by 50-70%). When the risk of cavitation disappears, so does the risk of a large number of operational disturbances that would otherwise result - such as excessive noise, energy loss, product damage and unnecessary wear on the pump. Low suction head is a common "problem" in miscellaneous applications, e.g. when pumping products with low boiling points or in processes that involve vacuums.

The Wi+ is unique among inducer pumps, since the NPSH requirement is kept to a minimum throughout its entire operating range. The inducer further enables the Wi+ pump to handle viscous or gaseous products beyond the range of other centrifugal pumps.

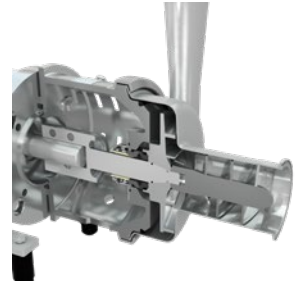

#### WS+ SELF-PRIMING PUMP



The self-priming Ws+ is designed to handle CIP return and other fluids with entrained air and foam. The unique design reduces the energy consumption and noise of traditional liquid ring pumps by using a high efficiency impeller that can be trimmed to match a specific duty. The Ws+ employs a built in eccentric air screw to form the liquid ring required for its self-priming capability.

#### Features and Benefits

- 20-90% more efficient than other liquid rings due to improved fluid flow through pump
- Performance optimized by matching impeller size to duty
- Low noise level: Due to its hydraulic design the noise level of the Ws+ is significantly lower than traditional liquid ring pumps
- 3-A approved
- Interchangeable with W+ parts. Inventory is reduced by sharing common parts
- Less prone to damage. Small objects can pass through pump with minimal damage

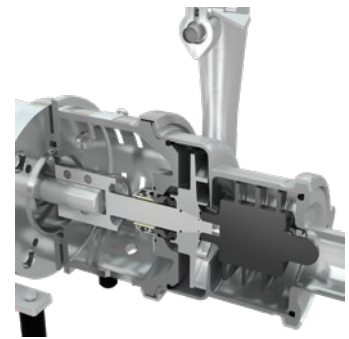

#### W+ MULTISTAGE PUMP

The W+ 140/50 offers three special features:



- Provides differential pressures up to 700 psi (48 bar)
- Can be used in processes with system pressures up to 870 psi (60 bar)
- Ensures optimum hygienic standards

And unlike other multistage pumps, it is CIP friendly. It has an open and semi-open impeller, eliminating any hiding place for bacteria. The W+ multistage pump is equipped with a heavy-duty bearing bracket that absorbs all radial and axial forces present in pumps of this kind. Therefore, the W+ 140/50 can use standard motors.

## WHP+ HIGH PRESSURE PUMP



The WHP+ is a high-pressure model of the W+ range. The pumps are designed to withstand system pressures up to 870 psi (60 bar) — such as those in certain reverse osmosis systems. The WHP+ pump's sturdy construction increases stability and dampens vibrations.

## WA+ ASEPTIC PUMP



Environmental requirements are getting stricter and stricter! But today, aseptic production is already essential to certain processes —including the manufacture of long life food and pharmaceutical products. The Wa+ pump is the perfect solution. All seals, including the shaft seal, are designed as double seals.

### Aseptic fitting

- Double mechanical shaft seals fitted for sterile flushing
- Double o-ring sealing of pump housing fitted for sterile flushing
- Special aseptic fittings fitted for sterile flushing

Wa+ pumps products ensure absolutely aseptic production processes with barrier media up to 320°F (150°C). With a Wa+ pump, the risk of contaminating the product and environment is thus reduced to an absolute minimum.

Pump with double seal  
barrier fluid at all  
connections

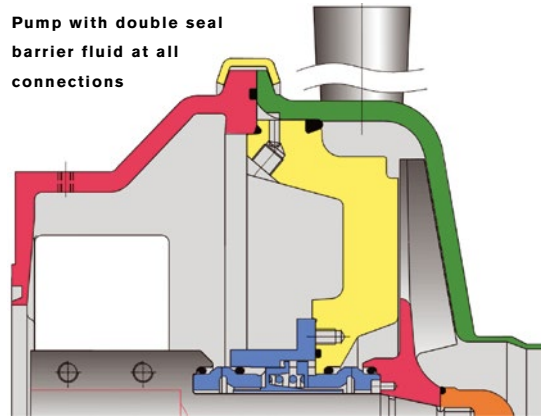

## ADDITIONAL INFORMATION

Watch the W+ Pump Animation

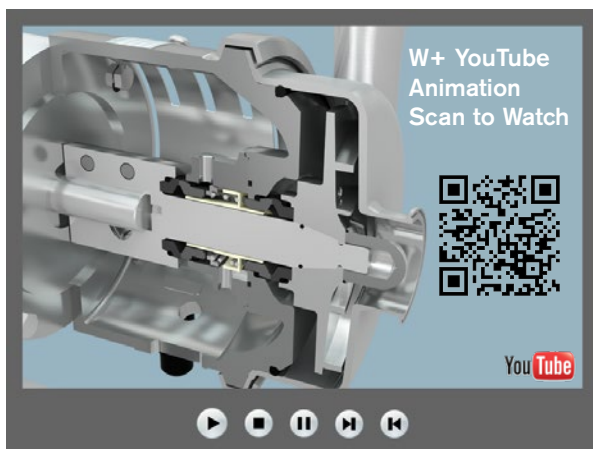

Find out Where to Buy locate your local distributor online.

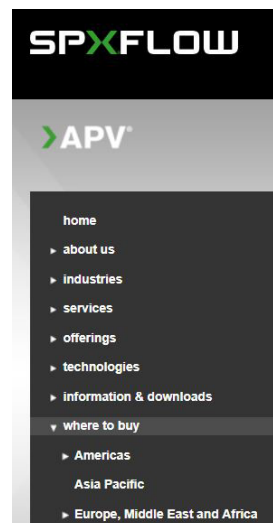

## W+ Series

### SANITARY CENTRIFUGAL PUMPS

# SPXFLOW



0508 4 BBENG  
[www.brownbros.co.nz](http://www.brownbros.co.nz)

Based in Charlotte, North Carolina, SPX FLOW, Inc. (NYSE: FLOW) is a multi-industry manufacturing leader. For more information, please visit [www.spxflow.com](http://www.spxflow.com)

#### **SPX FLOW**

611 Sugar Creek Road  
Delavan, WI 53115  
P: (262) 728-1900 or (800) 252-5200  
E: [answers.us@spxflow.com](mailto:answers.us@spxflow.com)

SPX FLOW, Inc. reserves the right to incorporate our latest design and material changes without notice or obligation.

Design features, materials of construction, dimensional data, and certifications as described in this bulletin, are provided for your information only and should not be relied upon unless confirmed in writing. Please contact your local sales representative for product availability in your region. For more information visit [www.spxflow.com](http://www.spxflow.com).

The green "y" and "x" are trademarks of SPX FLOW, Inc.

APV\_Pumps-Centrifugal-W+\_7016\_BRO\_US Version: 02/2021

Identification: APV-7016-US

COPYRIGHT © 2021 SPX FLOW, Inc.